



NHD-USB-TRX

USB2.0 over IP Transceiver

User Manual

Version: V1.0.0



Important Safety Instructions

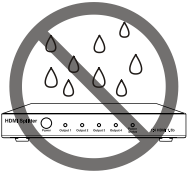

1. Do not expose this apparatus to rain, moisture, dripping or splashing and that no objects filled with liquids, such as vases, shall be placed on the apparatus.

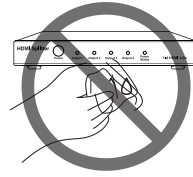

6. Clean this apparatus only with dry cloth.



2. Do not install or place this unit in a bookcase, built-in cabinet or in another confined space. Ensure the unit is well ventilated.

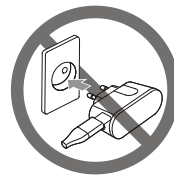

7. Unplug this apparatus during lightning storms or when unused for long periods of time.

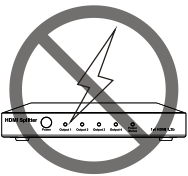

3. To prevent risk of electric shock or fire hazard due to overheating, do not obstruct the unit's ventilation openings with newspapers, tablecloths, curtains, and similar items.

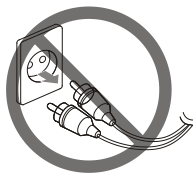

8. Protect the power cord from being walked on or pinched particularly at plugs.

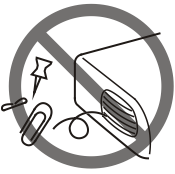

4. Do not install near any heat sources such as radiators, heat registers, stoves, or other apparatus (including amplifiers) that produce heat.



9. Only use attachments / accessories specified by the manufacturer.



5. Do not place sources of naked flames, such as lighted candles, on the unit.

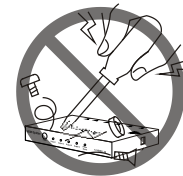

10. Refer all servicing to qualified service personnel.

Table of Contents

Introduction	3
Overview	3
Features	3
Package Contents	3
Specifications	3
Panel Description	4
Installation	5
Typical Applications	5
(1) Point to Point.....	5
(2) Point to Multi-point	5
(3) Interoperable with NHD-500 Series	6
Device Control	6

Introduction

Overview

This product is a USB 2.0 transceiver that can work as either a transmitter or a receiver through configuration for USB expansion over Gigabit Ethernet. Interoperable with NetworkHD 500 series family, it provides low-cost solution for the applications where only USB 2.0 signal extension is required.

Features

- A USB transceiver with support of configuration between transmitter and receiver mode
- High speed USB 2.0 transmission over Gigabit Ethernet
- Works as a local USB hub with support of USB 3.2 Gen 2 in Transmitter mode
- Supports PoE 802.3at (PoE+) to be powered by a remote PoE-capable switch
- Supports point-to-multipoint application—up to seven remote USB peripherals are able to associated with one transmitter in USBoP mode
- Unlimited in quantity of the associated keyboards and mice in KVMoIP mode
- Interoperable with the NHD-500 series family, providing high-effective, economic solution for the requirement of USB 2.0 signal extension
- Supports 802.1x
- Controlled by the NetworkHD Pro controller

Package Contents

- 1x NHD-USB-TRX Transceiver
- 2x Mounting Brackets
- 2x Mounting Screws (M3*L5)

Specifications

Technical	
USB Host	1x USB 3.2 Gen Type-B, 10Gbps
USB Device	Local end: 3x USB 3.2 Gen 2 Type-A, 10Gbps (Applies to TX Mode) Remote end: 3x USB 2.0 Type-A, 480Mbps (Applies to RX Mode)
LAN	1x RJ45 (PoE+)
Control Method	DIP Swith (for TX/RX configuration); NHD-CTL-PRO v2; Telnet API
Power	
Power Supply	12V DC / PoE+
Max Power Consumption	No Load: 2.2W Full Load with 3A current: 18.5W
Environmental	
Operating Temperature	0 to + 45°C (32 to + 113 °F), 10% to 90%, non-condensing
Storage Temperature	-20 to +70°C (-4 to + 158 °F), 10% to 90%, non-condensing
ESD Protection	Human Body Model: ±8kV (air-gap discharge) / ±4kV (contact discharge)
Dimensions and Weight	
Dimensions (WxHxD)	5.51" x 0.93" x 3.54" (140mm x 23.5mm 90mm)
Regulatory	
Safety and Emission	CE FCC RoHS RCM EAC UKCA

Panel Description

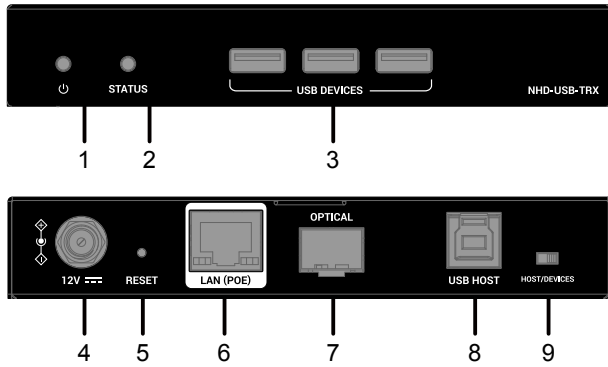

#	Name	Description
1	Power LED	<p>On: The device is powered on. Blinking: The device is booting. Off: The device is powered off.</p>
2	Status LED	<p>In TX mode: On: The device is powered on Blinking slowly: The device is being upgraded Blinking quickly: Find me function is activated through telnet API for positioning the target device For more information refer to the separate API document</p> <p>In RX mode: On: The device is connected to a network and associated with a valid USB transmitter Blinking: The device is connected to a network but associated with an invalid USB transmitter Blinking slowly: The device is being upgraded Blinking quickly: Find me function is activated through telnet API for positioning the target device For more information refer to the separate API document Off: The device is not connected to a network. / The device is connected to a network but not associated with any USB transmitter</p>
3	USB Devices	<p>In TX mode: USB 3.2 Gen 2 Type-A ports. In RX mode: USB 2.0 Type-A ports. Connect to USB peripherals for USB expansion.</p> <p>Note: In TX mode, the device works as a local USB hub. If powered by power adapter, the three ports share output of 3A current in total; if powered by PoE, the three ports share output of 2.5A current in total.</p>
4	12V	<p>Connect to a DC 12V power adapter for power input Tip: Using a DC 12V 2A or above power adapter is recommended, otherwise the device running with a maximum load may suffer from insufficient power supply.</p>
5	RESET	<p>When the device is powered on, use a pointed stylus to press and hold the recessed RESET button for five or more seconds, and then release it, it will reboot and restore to its factory defaults.</p> <p>Note: When the settings are restored, your custom data is lost. Therefore, exercise caution when using the RESET button.</p>
6	LAN (POE)	<p>Connect either the LAN (POE) or Optical port to a Gigabit Ethernet switch for IP stream transmission and device control. Default IP mode for the device is DHCP.</p>
7	OPTICAL	<p>Note: 1) If both Ethernet ports are connected to the switch, the first to connect to the switch will be used. 2) Connect the Optical port to the network switch using a single-mode or multimode SFP module (not included in package). The transmission distance may vary based on the SFP module in use.</p>
8	USB HOST	<p>USB 3.2 Gen 2 Type-B port. Connect to the USB host</p>
9	TX/RX	<p>DIP switch for toggling the working mode between TX and RX. Default setting: TX</p>

Note: The device can be powered by either a DC 12V power adapter or a PoE switch. If the device is connected to both, it prioritizes the DC 12V power adapter over the PoE Switch

Installation

Note: Before installation, please ensure the device is disconnected from the power source. The recommended installation height is within 2 meters above the ground.

Steps to install the device on a suitable location:

1. Attach the mounting brackets to the panels of both sides in diagonal direction using the screws (one at each side) provided in the package.

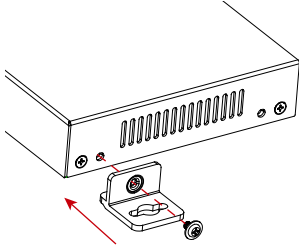

2. Install the brackets on the position as desired using screws (screws are not included).

Typical Applications

(1) Point-to-point

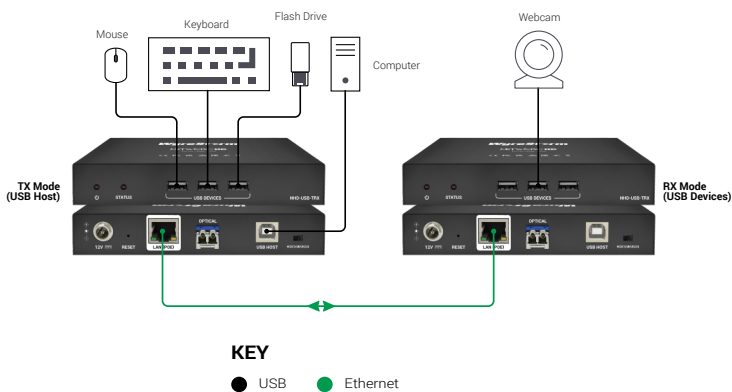

(2) Point-to-multipoint

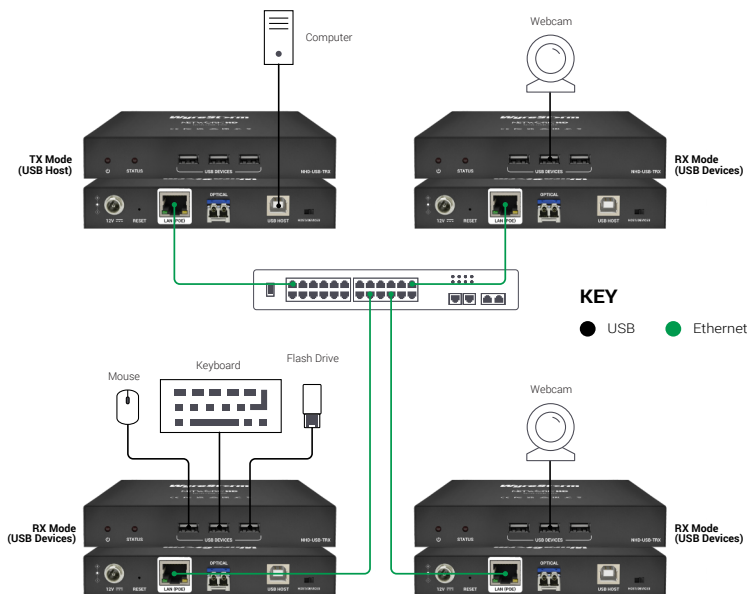

(3) Interoperable with NetworkHD 500 Series

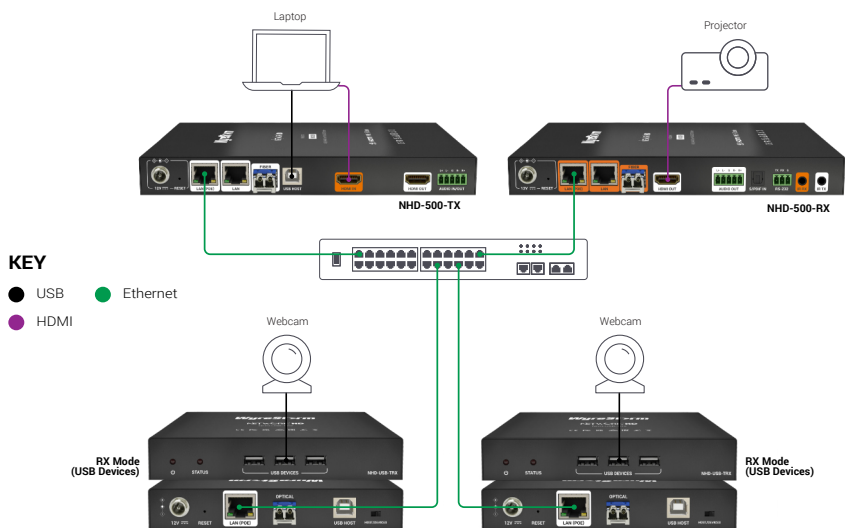

Device Control

The device supports USB signal routing and online firmware upgrade which can be realized on the NetworkHD Pro controller's web UI. For more information, see the user guide of the NetworkHD Pro controller.

