

ZLX-G2 Full-range loudspeaker

ZLX-8-G2, ZLX-12-G2, ZLX-15-G2, ZLX-8P-G2, ZLX-12P-G2,
ZLX-15P-G2

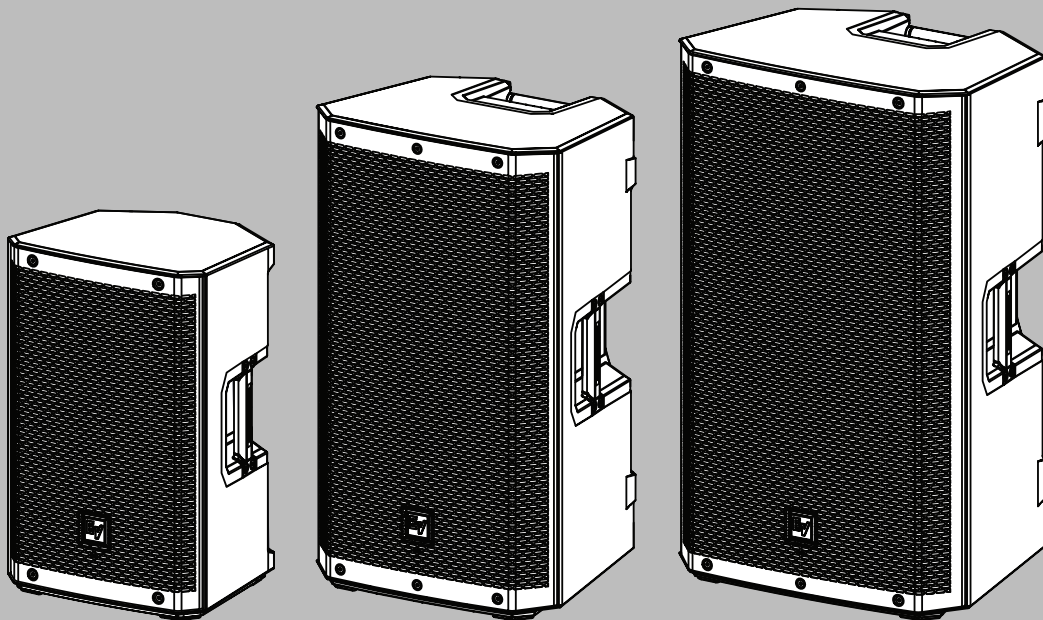





Table of contents

1	Safety	5
1.1	Important safety instructions	5
1.2	Precautions	7
1.3	Suspension	8
2	Product registration	9
3	Description	10
3.1	Short information	10
3.2	System features	11
4	Quick setup	12
5	Pairing the QuickSmart Mobile app	14
6	Tripod, pole mount and floor monitor operation	16
6.1	Tripod or pole mount	16
6.2	Floor monitor & kickback	18
7	Amplifier DSP	20
7.1	Amplifier DSP controls	20
7.2	System status	21
7.3	DSP controls	22
7.3.1	Loudspeaker DSP control menu	23
8	Input & Mixer operation	30
8.1	INPUT DSP control menu	30
9	Recommended configurations	33
9.1	Powered loudspeakers	33
9.1.1	Connecting with mobile device	33
9.1.2	Street musician performance	34
9.1.3	Bluetooth true wireless stereo (TWS)	35
9.1.4	Using as monitor	36
9.1.5	Daisy-chaining full-range systems	37
9.1.6	Stacking full-range systems with subwoofers	38
9.2	Passive loudspeakers	39
9.2.1	Basic stereo system using full-range systems	39
9.2.2	Using full-range systems as stage monitors	40
9.2.3	Stacking full-range systems with subwoofers	41
10	Troubleshooting	42
10.1	Passive loudspeakers	42
10.2	Powered loudspeakers	43
11	Technical data	46
11.1	Powered loudspeakers	46
11.2	Passive loudspeakers	47
11.3	Dimensions	48
12	Appendices	50
12.1	Warranty information	50
12.2	Effects (FX) list	50
12.3	OUTPUT list	51
12.4	INPUT list	54
12.5	Regulatory information	56
12.5.1	FCC information	56
12.5.2	Simplified Declaration of Conformity (sDoC) for Europe (CE)	57
12.5.3	Regulatory notice for CE/UKCA - Information concerning the use of apparatus	59

12.5.4	Certifications	60
12.5.5	Open Source Software licenses	62
12.5.6	Notices	80

1 Safety

1.1 Important safety instructions

 <p>WARNING: TO REDUCE THE RISK OF FIRE OR ELECTRIC SHOCK, DO NOT EXPOSE THIS APPLIANCE TO RAIN OR MOISTURE</p> <p>AVIS: RISQUE DE CHOC ELECTRIQUE, NE PAS OUVRIR.</p> <p>WARNING: THE MAINS PLUG OR AC INLET IS USED AS A DISCONNECT DEVICE. THE DISCONNECT DEVICE SHALL REMAIN READILY OPERABLE.</p> <p>WARNING: CONNECT ONLY TO MAINS SOCKET WITH PROTECTIVE EARTHING CONNECTION.</p> <p>WARNING: TO REDUCE THE RISK OF ELECTRIC SHOCK, DO NOT REMOVE COVER (OR BACK) AS THERE ARE NO USER-SERVICABLE PARTS INSIDE. REFER SERVICING TO QUALIFIED PERSONNEL.</p>		<p>The lightning flash with arrowhead symbol, within an equilateral triangle is intended to alert the user to the presence of uninsulated “dangerous voltage” within the product’s enclosure that may be sufficient magnitude to constitute a risk of electric shock to persons.</p>
		<p>The exclamation point within an equilateral triangle is intended to alert the user to the presence of important operating and maintenance (servicing) instructions in the literature accompanying the appliance.</p>
		<p>The asterisk within an equilateral triangle is intended to inform the user to necessary installation or removal instructions regarding equipment or hardware use relating to the system.</p>

1. Read and keep these safety instructions. Follow all instructions and heed all warnings.
2. Download the latest version of the applicable installation manual from www.electrovoice.com for installation instructions.



Information

Refer to the Installation Manual for instructions.

3. Follow all installation instructions and observe the following alert signs:



Notice!

Containing additional information. Usually, not observing a notice does not result in damage to the equipment or personal injuries.



Caution!

The equipment or the property can be damaged, or persons can be injured if the alert is not observed.



Danger!

Risk of electric shock.

4. **Clean only with dry cloth.** - Unplug the apparatus from the outlet before cleaning. Do not use liquid cleaners or aerosol cleaners.
5. **Condensation** - In order to avoid condensation; wait a few hours before turning on the equipment when it is transported from a cold to a warm space.
6. The apparatus shall not be exposed to dripping or splashing and no objects filled with liquids, such as vases, shall be placed on the apparatus.

**Danger!**

To reduce the risk of fire and electric shock, do not expose this apparatus to rain or moisture.

7. **Do not block any ventilation openings. Install in accordance with the manufacturer's instructions.** - Openings in the enclosure, if any, are provided for ventilation and to ensure reliable operation of the apparatus and to protect it from overheating. These openings must not be blocked or covered. This apparatus should not be placed in a built-in installation unless proper ventilation is provided or the manufacturer's instructions have been adhered to.
8. Do not install near any heat sources such as radiators, heat registers, stoves, or other apparatus (including amplifiers) that produce heat or in direct sunlight.
9. No naked flame sources, such as lighted candles, should be placed on the apparatus.
10. **Power cord options:**
 - **Mains plug**
 - Use a 3-pin mains plug that is registered with the Safety Authority.
 - Use a 2-pin mains plug that is certified¹ to EN 50075/IEC 60083 Standard C5 (shown in the Appendix S of Singapore Consumer Protection (Safety Requirements) Registration Scheme Information).
 - **Flexible cord**
 - Use a double insulated flexible cord that is certified¹ to the relevant IEC standards.
¹Certified by member of IECEE CB Scheme.
 - **Appliance connector**
 - Use an appliance connector certified¹ to IEC 60320.
¹Certified by member of IECEE CB Scheme.
11. **Do not defeat the safety purpose of the polarized or ground-type plug.** - A polarized plug has two blades with one wider than the other. A grounding type plug has two blades and a third grounding prong. The wider blade or the third prong are provided for your safety. If the provided plug does not fit into your outlet, consult an electrician for replacement of the obsolete outlet.
12. Mains powered equipment shall be connected to a mains power outlet socket with a protective earthing connection. An external, readily operable, mains plug or all-pole mains switch shall be installed.
13. To completely disconnect AC power from this apparatus, the power supply cord must be unplugged.



Warning! To prevent a shock hazard disconnect all power sources prior to system installation.

14. Unplug the apparatus during lightning storms or when unused for long periods of time.
15. Protect the power cord from being walked on or pinched particularly at plug, convenience receptacles, and the point where they exit from the apparatus.

**Danger!**

Overloading - Do not overload outlets and extension cords as this can result in a risk of fire or electric shock.

16. **Only use attachments/accessories specified by the manufacturer.** - Any mounting of the apparatus should follow the manufacturer's instructions, and should use a mounting accessory recommended by the manufacturer.
17. **Use only with the cart, stand, tripod, bracket or table specified by the manufacturer, or sold with the apparatus.** - When a cart is used, use caution when moving the cart/apparatus combination to avoid injury from tip-over. Quick stops, excessive force, and uneven surfaces may cause the appliance and cart combination to overturn.

**Caution!**

Tripod is not evaluated for safety with this loudspeaker. Check the specifications of the tripod stand to be certain it is capable of supporting the weight of the loudspeaker.

18. System installation and servicing by qualified personnel only, in accordance with applicable local codes. No user-serviceable parts inside.
19. Devices installed above 2 m height may cause injury when falling down. Preventive measures must be taken.
20. **Replacement parts** - When replacement parts are required, be sure the service technician has used replacement parts specified by the manufacturer or having the same characteristics as the original part. Unauthorized substitutions may result in fire, electric shock or other hazards.
21. Only replace the mains fuse of an apparatus with a fuse of the same type.
22. **Safety check** - Upon completion of any service or repairs to this apparatus, ask the service technician to perform safety checks to determine that the apparatus is in proper operating condition.

1.2

Precautions

- If an Electro-Voice loudspeaker is used outdoors on a sunny day, place the loudspeaker in a shaded or covered area. The loudspeaker amplifiers have protection circuits that temporarily shut the loudspeaker off when extremely high temperatures are reached. This can happen on hot days when the loudspeaker is in direct sunlight.
- Do not use Electro-Voice loudspeakers in an environment where temperatures are below 0°C (32°F) or exceed +35°C (95°F).
- Electro-Voice loudspeakers are easily capable of generating sound pressure levels sufficient to cause permanent hearing damage to anyone within normal coverage distance. Caution should be taken to avoid prolonged exposure to sound pressure levels exceeding 90 dB. To prevent hearing damage do not listen at high volume levels for long periods.

1.3 Suspension

**Warning!**

Suspending any object is potentially dangerous and should only be attempted by individuals who have a thorough knowledge of the techniques and regulations of suspending objects overhead. Electro-Voice strongly recommends all loudspeakers be suspended taking into account all current national, federal, state, and local laws and regulations. It is the responsibility of the installer to ensure all loudspeakers are safely installed in accordance with all such requirements. When loudspeakers are suspended, Electro-Voice strongly recommends the system be inspected at least once per year or as laws and regulations require. If any sign of weakness or damage is detected, remedial action should be taken immediately. The user is responsible for making sure the wall, ceiling, or structure is capable of supporting all objects suspended overhead. Any hardware used to suspend a loudspeaker not associated with Electro-Voice is the responsibility of others.

**Warning!**

Do not suspend this product in any other manner than explicitly described in this manual, or Electro-Voice installation guides. Suspending any object (loudspeaker) is potentially dangerous and should only be done by individuals with thorough knowledge of techniques, materials, and regulations for suspending objects overhead. Electro-Voice loudspeakers can only be suspended using accessories and hardware described in Electro-Voice manuals and installation guides. **Do NOT use handles to suspend the loudspeaker. Handles on Electro-Voice loudspeakers are intended to only be used for temporary transport by people. Items, such as fiber rope, wire rope, cables, or other types of materials cannot be used to suspend loudspeaker from the handles.** Any hardware used to suspend a loudspeaker not associated with Electro-Voice is the responsibility of others.

**Warning!**

Use of non-authorized accessories or attachments with this or any Electro-Voice product is at your own discretion. Use of non-authorized accessories or attachments can result in product malfunction, injury, or death.

The user assumes all liability and may result in the warranty being voided.

2

Product registration



Register your ZLX-G2: electrovoice.com/register

3 Description

Thank you for choosing an Electro-Voice portable loudspeaker system. Please take time to consult the manual to understand all the features built into your EV system and fully utilize its performance capabilities.

ZLX-G2 is the next generation of the best-selling pro-audio loudspeaker family from Electro-Voice. ZLX-G2 builds on the previous generation's class leading performance with increased output, wider frequency range, robust design and improved connectivity. This new generation includes many new features including remote control and mixing functions and wireless stereo streaming.

The ZLX-G2 family includes both powered and passive models in 15-inch, 12-inch, and new compact 8-inch 2-way configurations.

The composite enclosure features an improved design allowing for a 55-degree monitor angle. The 15-inch and 12-inch versions include a low angle 23-degree "kickback" angle for additional flexibility. All powered models feature a POWERED BY DYNACORD amplifier with built-in digital mixer and FX. The mixer and all speaker functions can be easily controlled from the Electro-Voice QuickSmart Mobile app via Bluetooth.

Integration and compatibility

ZLX-G2 is compatible with all other portable speakers from Electro-Voice and most other speakers on the market. ZLX-G2 uses industry standard connections, such as XLR and TRS or NL4, at common signal levels to be compatible with other products on the market.

Accessories

The ZLX-G2 family includes a select complement of accessories.

- Padded covers are available for all sizes of speakers.
- A "U" style wall bracket allows both vertical and horizontal mounting of 12 and 15-inch models.
- A universal pole-mount style wall bracket with a short arm is offered for the 8-inch models and will be limited to vertical orientation only. Additionally, a second universal pole-mount style bracket with a longer arm will work with other speaker models in the Electro-Voice line-up.
- A truss clamp adapter is available for 8-inch models, allowing for rotation (panning) of the loudspeaker.

3.1 Short information

This document is applicable to these products:

CTN	Description
ZLX-8P-G2-US	8" 2-way powered speaker, US cord
ZLX-12P-G2-US	12" 2-way powered speaker, US cord
ZLX-15P-G2-US	15" 2-way powered speaker, US cord
ZLX-8P-G2-EU	8" 2-way powered speaker, EU cord
ZLX-12P-G2-EU	12" 2-way powered speaker, EU cord
ZLX-15P-G2-EU	15" 2-way powered speaker, EU cord

CTN	Description
ZLX-8-G2	8" 2-way passive speaker
ZLX-12-G2	12" 2-way passive speaker

CTN	Description
ZLX-15-G2	15" 2-way passive speaker

3.2

System features

Powered loudspeakers

- **High Quality Stereo Bluetooth® streaming**
Bluetooth® stereo streaming and linking for true wireless stereo (TWS) setup. Users are able to pair and link to two ZLX-G2 powered loudspeakers in a stereo system wirelessly via Bluetooth® for music streaming.
- **Easy to use with QuickSmart Mobile app and Electro-Voice's Intuitive User Interface**
ZLX-G2 powered loudspeakers feature Electro-Voice's intuitive QuickSmart DSP with single encoder and push key interface for simple and quick setup. ZLX-G2 can be paired via Bluetooth® to a mobile device with the QuickSmart Mobile app installed to provide easy remote control of all audio and mixing functions. The QuickSmart Mobile app allows pairing and grouping of up to six Bluetooth®- enabled loudspeakers, in any combination, including EVERSE , ELX200, and EVOLVE families.
- **POWERED BY DYNACORD with built-in digital 4-channel mixer**
ZLX-G2 powered loudspeakers feature a built-in 4-channel mixer with FX, EQ, automatic feedback suppression and ducking functions. The mixer includes two XLR/TRS combo jacks, including 24V phantom power on **INPUT 1** (XLR) and Hi-Z instrument compatibility on **INPUT 2** (¼-inch Hi-Z connector). The mixer also includes Stereo Bluetooth®.
- **Full color LCD display**
- **Easy control access in monitor mode and dual monitor angle**
Improved angled cabinet design allows for a 55-degree monitor angle, saving up to two feet of stage space. The amp panel is easy to access in monitor position. Low-angle 23-degree kickback position provides a second monitor orientation for 15-inch and 12-inch models.

Passive loudspeakers

- ZLX-G2 is the next generation of the best-selling pro-audio loudspeaker series from Electro-Voice
- Increased maximum SPL output and extended frequency response
- Robust and ergonomic design for day-to-day durability and portability
- Recommended to use with Dynacord DSP power amplifiers
- SONICUE integration - optimized speaker settings for best performance

4 Quick setup

The ZLX series loudspeakers from Electro-Voice are fully integrated audio systems with carefully matched electronics and transducers. These products make it easy to setup a high quality sound system quickly with a minimum amount of cables and external electronics.

Full-Range powered loudspeaker

Models: ZLX-8P-G2-US, ZLX-12P-G2-US, ZLX-15P-G2-US, ZLX-8P-G2-EU, ZLX-12P-G2-EU, and ZLX-15P-G2-EU.

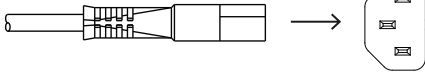
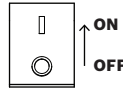
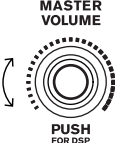
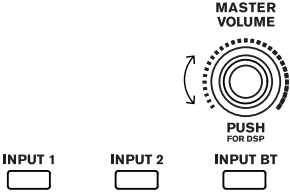
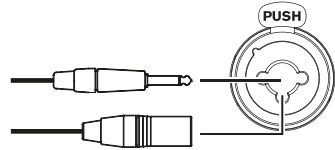
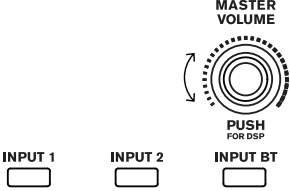
Step	Illustration
<p>1. Connect the AC power cord from a grounded receptacle to the MAINS IN.</p>	
<p>2. Switch power to ON.</p>	
<p>3. Adjust the volume to 0 dB by using the MASTER VOLUME knob.</p>	
<p>4. Push the input selection soft key for INPUT 1 or INPUT 2 if using an XLR or 1/4-inch (6.35 mm) cable. Use the MASTER VOLUME knob to adjust INPUT LEVEL to MUTE. Repeat for each input channel as needed.</p>	
<p>5. Connect an audio source using an XLR, TRS, or TS cable to INPUT 1 or INPUT 2. Ensure audio source is MUTE or at a low level before making connection. After connection is made, increase the source's output to a reasonable level. Ensure that the source is not being clipped.</p>	
<p>6. Adjust the INPUT LEVEL by using the MASTER VOLUME knob until the signal peaks are just below maximum level or the required output is achieved. If PK or PEAK is indicated, turn the level down until the PK or PEAK indication disappears. Press the input selection soft key again to exit the channel menu. Use the same process for other inputs if in use. Adjust the input levels of each input to achieve the desired mix.</p>	

7. Using the **MASTER VOLUME** knob, adjust the volume until you get the required output from the loudspeaker.

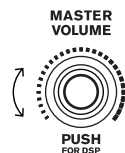

5 Pairing the QuickSmart Mobile app

The EV QuickSmart Mobile app for tablets and smartphones is available for download from the Apple App Store and the Google Play Store.

Download and check the app for the latest firmware updates to enjoy optimal audio performance and maximize your control of the system.



Notice!

The EV QuickSmart Mobile app is designed to only find loudspeakers from Electro-Voice featuring Bluetooth® control functionality.

The EV QuickSmart Mobile app will not display other types of Bluetooth® devices, e.g. phones, laptops, tablets, or headsets.

Prior to pairing the EV QuickSmart Mobile app with Electro-Voice loudspeakers:

1. Ensure that Bluetooth® is enabled on the smartphone or tablet.
2. Ensure that pairing mode is enabled on the loudspeaker.

To place the loudspeaker in pairing mode for both control and streaming:

1. Press and hold **INPUT BT** until **Pairing Mode On** and the 4-digit ID is shown on the LCD. Pairing mode can be enabled through the LCD menu for control and streaming separately. The loudspeaker remains in control pairing mode for about 2 minutes. If control pairing fails, repeat this step.

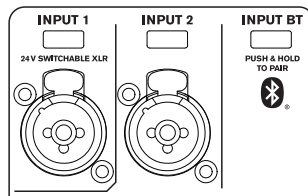

2. Navigate to your mobile device's Bluetooth® settings menu, find the ZLX-G2 loudspeaker with the matching 4-digit ID and ensure you are paired to the loudspeaker. This will pair the mobile device to the ZLX-G2 loudspeaker for audio streaming.
3. Continue to the next step to pair for control.



Notice!

For Android devices running Android version 11 or older, ensure location services are allowed. Electro-Voice does not collect, store, or track user location data or personal information.

First time pairing

1. Open the EV QuickSmart Mobile app. 
2. **Select your Speakers** is displayed on the screen. The EV QuickSmart Mobile app is looking for available Bluetooth® enabled Electro-Voice loudspeakers. The available loudspeakers are displayed on the screen.
3. Tap the loudspeaker you want to pair with the app. The selected loudspeaker will have a line under it acknowledging it is selected.

4. Repeat the previous step until all of the required loudspeakers are selected.
5. Tap the **CONNECT** button.
6. The app connects with the selected loudspeaker.
You will get a message from iOS/iPadOS/Android about pairing for each device which has to be accepted.

**Notice!**

If the message "Bluetooth Connection failed" appears, ensure that control pairing mode is enabled in the loudspeaker.

7. Tap **PAIR** on the device to accept pairing to the loudspeakers.
The app can connect to up to six loudspeakers.

Subsequent pairing

To pair additional loudspeakers with the EV QuickSmart Mobile app:

1. Tap the EV QuickSmart Mobile app icon. 
2. **Select your Speakers** is displayed on the screen.
The EV QuickSmart Mobile app is looking for available Bluetooth® enabled Electro-Voice loudspeakers. The available loudspeakers are displayed on the screen.
3. Tap the loudspeaker you want to pair with the app.
The selected loudspeaker will have a line under it acknowledging it is selected.
4. Repeat the previous step until all of the required loudspeakers are selected.
5. Tap the **CONNECT** button.
The app connects with the required loudspeaker.
The app can connect to up to six loudspeakers.

6 Tripod, pole mount and floor monitor operation

6.1 Tripod or pole mount

ZLX portable loudspeakers mount on a tripod stand or on a pole above a subwoofer.

Mounting a loudspeaker on a tripod stand

**Caution!**

Tripod is not evaluated for safety with this loudspeaker. Check the specifications of the tripod stand to be certain it is capable of supporting the weight of the loudspeaker.

**Caution!**

Do not stack additional loudspeakers.

**Caution!**

We recommend that two or more persons lift and place heavier loudspeakers. Single person lift and placement of heavier loudspeakers could cause injury.

To mount a loudspeaker on a tripod stand, do the following:

1. Place the tripod stand on a level and stable surface.
 - Fully extend the legs on the tripod stand.
 - Do not compromise the tripod stand's structural integrity by trying to make the stand taller.
 - Do not attempt to mount more than one loudspeaker on a stand designed for a single loudspeaker.
2. Loosen the set screw.

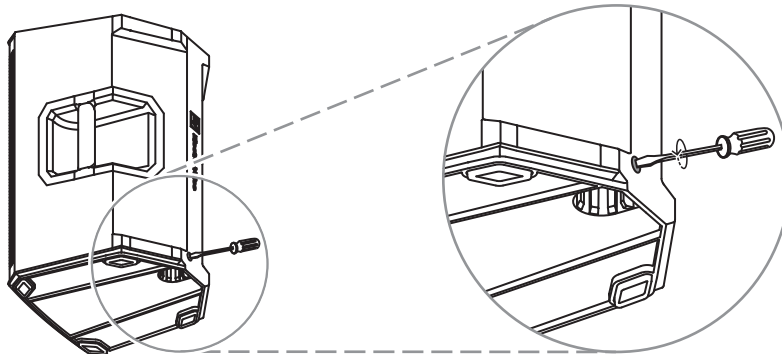

Figure 6.1: 8-inch models

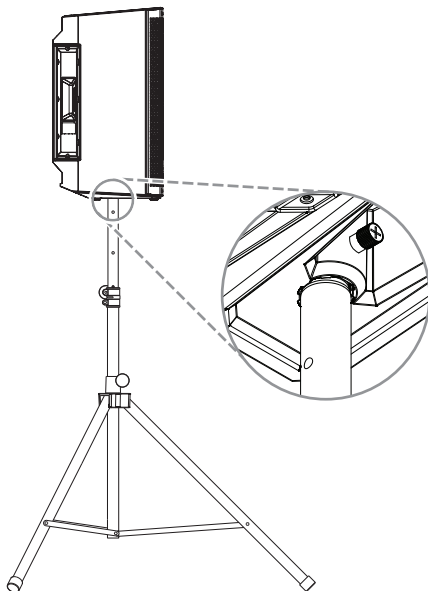
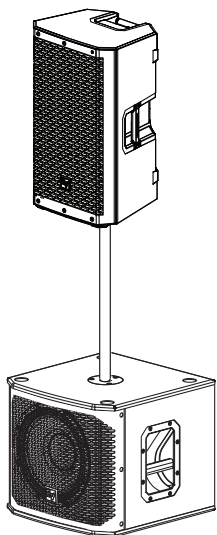

Figure 6.2: 12- and 15-inch models

3. Lift the loudspeaker using two hands.
4. Set the pole cup located on the bottom of the loudspeaker onto the pole.
5. Tighten the set screw to secure the loudspeaker to the pole.

Mounting a loudspeaker on a pole



Caution!

We recommend that two or more persons lift and place heavier loudspeakers. Single person lift and placement of heavier loudspeakers could cause injury.

To mount a loudspeaker on a pole, do the following:

1. Place the subwoofer on a level and stable surface.
2. Insert the pole into the pole cup on the top of the subwoofer.

3. If you are using a threaded pole mount, turn the pole clockwise to secure the pole to the subwoofer.
OR
If you are not using a threaded pole mount, continue to the next step.
4. Loosen the set screw.
5. Lift the loudspeaker using two hands.
6. Set the pole cup located on the bottom of the loudspeaker onto the pole.
7. Tighten the set screw to secure the loudspeaker to the pole.

**Caution!**

Do not stack additional loudspeakers.

6.2 Floor monitor & kickback

ZLX-G2 loudspeakers may be used as a floor monitor or in kickback position by placing the loudspeaker on one of the two integrated monitor angles.

Setting up a loudspeaker as a floor monitor

To set up a loudspeaker as a floor monitor:

1. Place the loudspeaker on a level and stable surface.
2. Safely route cables to prevent injury to performers, production crew, and audience members.
3. Set the loudspeaker location to **MONITOR** in the DSP control menu.

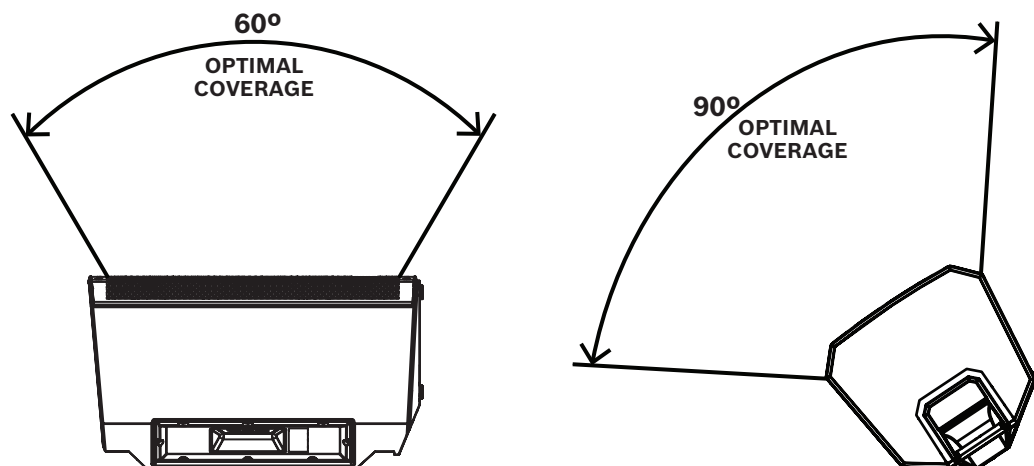

Figure 6.3: Optimum coverage in MONITOR position (side view left and front view right)

Setting up a loudspeaker in kickback position

Kickback monitor position is available in 12-inch and 15-inch ZLX-G2 models.

To set up a loudspeaker in kickback position:

1. Place the loudspeaker on a level and stable surface.
2. Tilt the loudspeaker rearward to rest securely in the kickback position.
3. Safely route cables to prevent injury to performers, production crew, and audience members.
4. Set the loudspeaker location to **KICKBACK** in the DSP control menu.

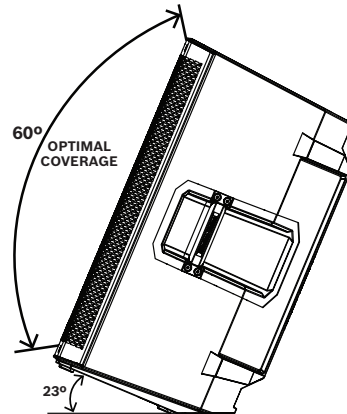

Figure 6.4: Optimum coverage in KICKBACK position



Notice!

Secure cables with wire ties or tape whenever possible.

7 Amplifier DSP

ZLX-G2 powered loudspeakers feature a built-in 4-channel mixer with FX, EQ, automatic feedback suppression and ducking functions. The mixer includes two XLR/TRS combo jacks, including 24V phantom power on **INPUT 1** (XLR). **INPUT 2** includes an unbalanced ¼-inch Hi-Z connector for instruments or high impedance microphones. The mixer also includes Stereo Bluetooth®.

7.1 Amplifier DSP controls

The amplifier has a combination of controls and connectors to ensure the most versatile loudspeaker system.

Loudspeaker control and monitoring interface

These DSP control menu selections are available for the ZLX-G2 .

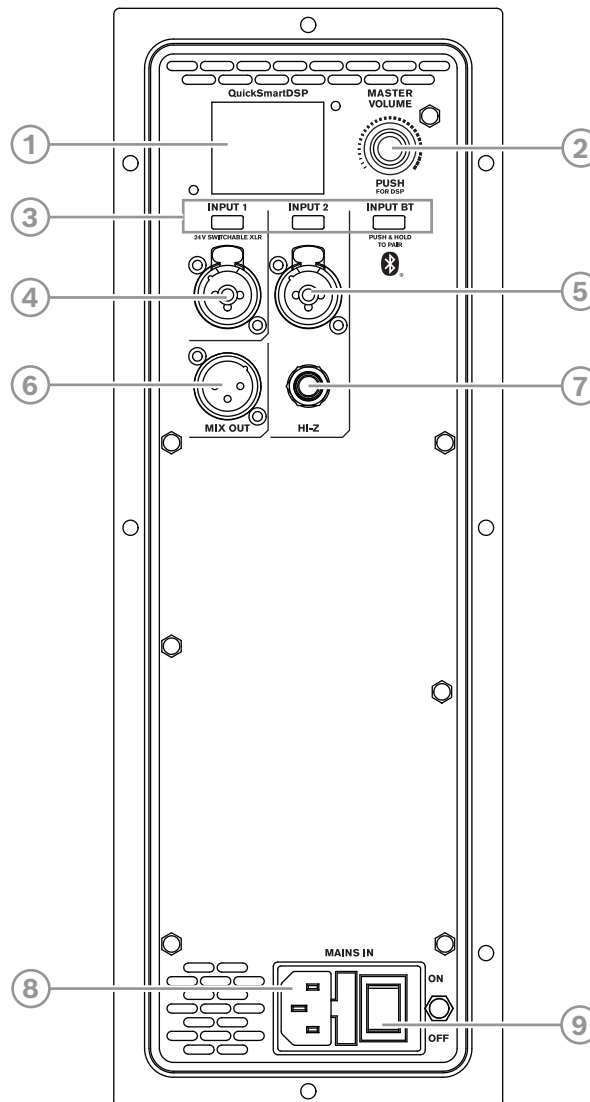

1. **LCD** – DSP control and monitoring interface.
2. **MASTER VOLUME** - Adjusts the sound level and navigates the DSP control menu.
DSP - Scroll through the menu and select the available choices. Push the **MASTER VOLUME** knob to enter the DSP control menu.

3. **Input selection soft keys** - Press the soft key to select the input and access the DSP control menu for the channel. Press the softkey a second time to deselect the channel and return to the main DSP.
4. **INPUT 1** - Balanced INPUT for the connection of signal sources like mixing consoles, instruments, or microphones. Connections can be established using ¼-inch TRS or XLR connectors. The XLR connector is switchable for 24V phantom power.
5. **INPUT 2** - Balanced INPUT for the connection of signal sources like mixing consoles, instruments, or microphones. Connections can be established using ¼-inch TRS or XLR connectors
6. **MIX OUT** - XLR output sends either the mix of all input signals or the stereo L or stereo R signal to another loudspeaker or subwoofer.
7. **Hi-Z** - High impedance connection to connect an instrument or high impedance microphone via a ¼-inch TS cable. Shared with INPUT 2.
8. **MAINS IN** – AC connection is established via an IEC-connector.
9. **POWER** - Switch for power **ON** or **OFF** of the loudspeaker. The LCD screen lights up when the power is turned **ON**, after approximately three seconds.

7.2 System status

Normal

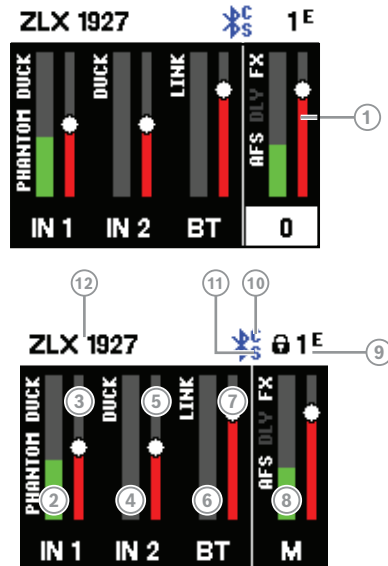

1. Indicates the master gain of the system in dB. The range is from -80 dB to +10 dB, in 1 dB increments.
2. **IN 1** - VU meter displays the signal level of INPUT 1 into the amplifier INPUT 1 connector. The display of **PHANTOM** indicates 24V phantom power is switched on.
 1. Input level control for **IN 1**.
 2. **IN 2** - VU meter displays the signal level of INPUT 2 into the amplifier INPUT 2 connector.
 3. Input level control for **IN 2**.
 4. **BT** - VU meter displays the signal level of INPUT BT into the amplifier from Bluetooth® streaming connection.
 5. Input level control for **BT**.
 6. **M** - VU meter displays the signal level of the MAIN output.

7. **Status display** - Alternately shows the following:
 - 1** - Indicates the selected preset number. There are five user-defined presets available.
 - E** - Edited. Indicates the preset is not saved. When the preset is saved, the **E** is not displayed.
 - Lock status** - Indicates that the LCD display and controls are locked. Press the **MASTER VOLUME** knob or channel select soft key to unlock.
8. **C** - Bluetooth control app. The available options are:
 - Off - disabled
 - Flashing - pairing mode
 - Solid - connected
9. **S** - Bluetooth audio streaming. The available options are:
 - Off - disabled
 - Flashing - pairing mode (120s)
 - Solid - connected
10. Loudspeaker 4-digit ID to pair via Bluetooth®.

System protection

System protection limiters indicate when a system is exceeding recommended usage by indicating input **PEAK (PK)** or output **LIMIT** on the LCD display.

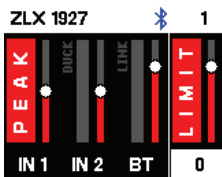

PEAK (PK)

PEAK (PK) indicates that the signal to the loudspeaker is too high, resulting in a clipped signal into the loudspeaker.

If **PEAK (PK)** is shown:

- ▶ Reduce the **INPUT GAIN** and/or the signal on the mixer or source equipment.

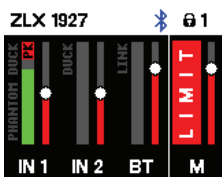

LIMIT

LIMIT protects the loudspeaker from short-term peaks and long-term overload, which can cause distortion. When **LIMIT** is displayed on the screen, the limiter is active.

If the **LIMIT** indication is shown often or continuously:

- ▶ Reduce the output volume (**MASTER VOLUME**). This is strongly recommended.

AMP HOT!

AMP HOT! indicates that the amplifier has heated up to a point where the loudspeaker will cut out or shut down.

If **AMP HOT!** is shown:

- ▶ Make sure the system is not in direct sunlight or near another heat source.
- ▶ Ensure that the system's airflow is not obstructed and that the rear panel is not covered.
- ▶ If possible, switch off the system and give it time to cool down.

After cooling down, if the system still displays **AMP HOT!**, contact your Sales or Customer Service Representative.

7.3

DSP controls

An integrated DSP control menu allows the user to select multiple DSP system settings on the loudspeaker.

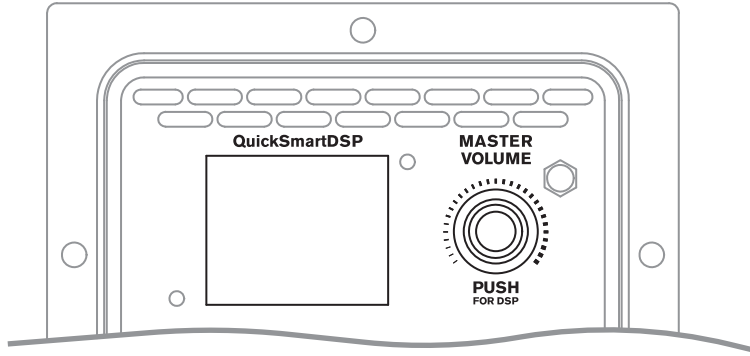

Accessing the DSP control menu

To access the DSP control menu:

1. Push the **MASTER VOLUME** knob.
The DSP control menu appears.
2. Using the **MASTER VOLUME** knob, scroll through the menu items.
3. Push the **MASTER VOLUME** knob to select the menu item you want to modify.
The focus moves to the parameters on the right side of the DSP control menu.
4. Using the **MASTER VOLUME** knob, scroll through the parameters.
5. Push the **MASTER VOLUME** knob to confirm the selected parameter.
The setting is saved. The focus returns to the menu items on the left side of the DSP control menu.
6. Repeat steps 2 through 5 to modify additional DSP and system settings.
7. Select **EXIT** to return to the home screen.

7.3.1

Loudspeaker DSP control menu

The loudspeaker DSP control menu selections are available for the ZLX-G2 loudspeakers. Refer to *OUTPUT list*, page 51 for the complete menu list.

EXIT menu

The EXIT menu is used to return to the home screen.



Notice!

The display returns to the home screen after 30 seconds of inactivity.

MODE menu

The **MODE** menu is used to configure the type of sound the loudspeaker delivers.

Available options for this selection are: **MUSIC**, **LIVE**, **SPEECH**, **CLUB**, and **FRFR-GUITAR**.



- **MUSIC** - is used for recorded music playback.
- **LIVE** - is used for live sound applications.
- **SPEECH** - is used for spoken word applications.
- **CLUB** - is used for recorded electronic music playback when more bass response is desired.
- **FRFR-GUITAR** - Full Range Flat Response for use with guitar profiling hardware.

The default is **MUSIC**.

LOCATION menu

The **LOCATION** menu is used to optimize the loudspeaker for different boundaries.

Available options for this selection are: **TRIPOD**, **KICKBACK**, **MONITOR**, and **WALL**.

- **TRIPOD** - is used when the loudspeaker is placed on a tripod stand or placed on a pole.
- **KICKBACK** - is used when the loudspeaker is placed on the angled rear kickback position. This setting compensates for the amount of low frequency boost created by placing the loudspeaker on a level and stable flat surface.
- **MONITOR** - is used when the loudspeaker is placed on the angled monitor panel in monitor position. This setting compensates for the amount of low frequency boost created by placing the loudspeaker on a level and stable flat surface.
- **WALL** - is used when the loudspeaker is mounted to the wall using the mounting bracket (mounting bracket accessory sold separately). This setting compensates for the amount of low frequency boost created by placing the loudspeaker close to the wall.

The default is **TRIPOD**.

SUB menu

The **SUB** menu is used to select a high pass frequency for use with a subwoofer.

Available options for this selection are: **OFF**, **80 Hz**, **100 Hz**, **120 Hz**, **150 Hz**, **ELX118SP**, **ETX-15SP**, **ETX18-SP**, **80 Hz**, and **ZXA1-SUB**. The **100 Hz**, **120 Hz**, and **150 Hz** choices are generic high pass settings for use with other subwoofers. The **ELX200-12SP**, **ELX200-18SP**, **EKX-15SP** and **EKX-18SP** settings are specifically optimized for subwoofers by including delay for best summation.

The default is **OFF**.

TREBLE control

The **TREBLE** control is used to adjust the high frequency performance of the loudspeaker for different applications or personal preference. The parameter controls a high shelving filter.

The default is **0 dB**.

MID control

The **MID** control is used to adjust the midrange frequency performance of the loudspeaker for different applications or personal preference.

The default is **0 dB**.

BASS control

The **BASS** control is used to adjust the low frequency performance of the loudspeaker for different applications or personal preference. The parameter controls a low shelving filter.

The default is **0 dB**.

MAIN GEQ menu (default)

The **MAIN GEQ** menu is used to adjust the frequency response of the loudspeaker for different applications or personal preference. There are seven different EQ filters available centered at the following frequencies: 63, 160, 400, 1.0K, 2.5K, 6.0K & 12K Hz.

The range of each filter is -12 dB to +12 dB.

The default value for each filter is **0 dB**.

MAIN PEQ menu

The **MAIN PEQ** menu is used to adjust the frequency response of the loudspeaker for different applications or personal preference. There are seven equalization filters available.

The filter type is selectable between the following:

PEQ - Parametric Equalization Filters shape the sound using peak/dip bell shaped filters which have three controls.

- **Q** - Quality Factor defines the bandwidth of the filter. A lower **Q** provides a wider bandwidth and a higher **Q** provides a narrower bandwidth.
- **FREQ** - selects the center frequency of the EQ filter.
- **GAIN** - sets the amount of increase or reduction of the equalization filter.

LOW/HI SHELF - Shapes the sound using a shelving type filter that can be applied to the low frequency or high frequency response using two controls:

- **FREQ** - sets the center frequency of the filter. For the **LOW SHELF** filter the **GAIN** of the filter tapers off above the frequency selected. For the **HIGH SHELF** filter the **GAIN** of the filter tapers off below the frequency selected.
- **GAIN** - sets the amount of increase or reduction of the signal below or above the **FREQ** setting.

LOW/HI PASS - Pass band filters that shape the sound by only passing signal above or below the selected frequency.

- **FREQ** - sets the corner frequency for the pass band filter. For **HI PASS** filters all frequencies above the selection will be passed through. Frequencies below the setting will be tapered off. For **LOW PASS** filters all frequencies below the selection will be passed through. Frequencies above the selection will be tapered off.

FX & FX ENABLE

The **FX** control is used to select the desired effect (e.g. reverb, chorus, delay, etc.) to apply to the FX send. The FX send level is independently controlled in the INPUT 1 and INPUT 2 FX control. The **FX ENABLE** turns **ON** or **OFF** the effect globally. **FX ENABLE** can be toggled with a footswitch.

AFS (automatic feedback suppression)

The 12-band AFS can be engaged to reduce unwanted feedback frequencies when microphones or instruments with pickups are used. Feedback occurs when sound from the loudspeaker enters the microphone or pickup and is amplified by the loudspeaker and played back again. High levels or extended periods of feedback can damage hearing and equipment.

Available options for this selection are **OFF** and **ON**.

Reducing feedback

To reduce feedback:

1. Set the loudspeaker and microphone or instrument according to your performance. Follow appropriate microphone placement and use practices:
 - Do not place the microphone directly in front of the loudspeaker. Refer to the user manual of your microphone to know the pickup and rejection patterns of your microphone.
 - Avoid placing music stands, tablets, or other large flat objects near the microphone such that they can cause audio reflections into the microphone.
 - Use proper microphone technique when speaking, singing or playing by an instrument to avoid using excessive input gain. For example, hold the microphone close to your mouth when performing.
 - Engage appropriate input channel **PRESET** for your application: **LOW CUT 80 Hz**, **LOW CUT 120 Hz**, **VOCAL MIC**, **VOICE FILTER**, **SPEECH**, **ACOUSTIC GUITAR**, etc. Refer to INPUT DSP control menu.

- Do not cup the microphone element with your hands while speaking or singing. Only hold the microphone by the handle or body as per the microphone manufacturer's recommendation.
2. Enable AFS in the DSP control menu or FX section of the QuickSmart Mobile app. This will enable AFS on **INPUT 1** and **INPUT 2**.
 3. Slowly turn up the output of the loudspeaker, and begin sound checking your microphone or instrument.
 4. As you hear feedback, allow a few seconds for the AFS to detect and to reduce the feedback.
 5. Continue sound check until no additional feedback tones are generated.

MIX OUT menu

The **MIX OUT** menu is used to select which signal(s) should be output at **MIX OUT** and which signal should be delivered by the loudspeaker.

- **L+R** - The left and right signals of all inputs are summed. The sum is output at **MIX OUT** and is delivered by the loudspeaker (default).
- **L** - Only the panned left signal of all inputs is output at **MIX OUT**. The loudspeaker will deliver only the right signal.
- **R** - Only the panned right signal of all inputs is output at **MIX OUT**. The loudspeaker will deliver only the left signal.

BLUETOOTH menu

The **BLUETOOTH** menu is used to set the Bluetooth® functionality of the loudspeaker.

ON/OFF - The **ON/OFF** menu controls whether Bluetooth® functionality is enabled or disabled on the loudspeaker.

CONTROL PAIR - The **CONTROL PAIR** menu is used to enable the QuickSmart Mobile app wireless control and monitoring application. Available options for this selection are: **ON** or **OFF**.

The default is **OFF**.

AUDIO PAIR - The **AUDIO PAIR** menu is used to stream audio from your Bluetooth® enabled device to the loudspeaker system. Available options for this selection are: **PAIRING**, **ON** or **OFF**.

The default is **OFF**.

LINK SPEAKERS

The **LINK SPEAKERS** function allows two ZLX-G2 loudspeakers to be linked over Bluetooth® in true wireless stereo for Bluetooth® audio streaming only.

To link two ZLX-G2 loudspeakers:

1. Pair one of the ZLX-G2 loudspeakers via Bluetooth® to a mobile device. Refer to *Pairing the QuickSmart Mobile app*, page 14 for pairing instructions.
2. In both ZLX-G2 loudspeakers, navigate to the **BLUETOOTH** menu in the Main DSP menu.
3. In both ZLX-G2 loudspeakers, select **LINK SPEAKERS**.

The LCD display will show **LINKING SPEAKERS...** while establishing connection between both ZLX-G2 loudspeakers. When the connection is established, the menu will display **UNLINK SPEAKERS**.

In the **BLUETOOTH** menu below **LINK SPEAKERS**, the stereo channel selection will appear.

4. Select the appropriate stereo channel selection for each ZLX-G2 loudspeaker: **L+R** (mono), **L**, or **R**.

Note: This is stereo image from the audience's perspective, also known as House L & R.

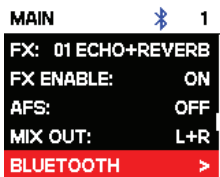

LED menu

The **LED** menu shows power on and indicates limit. Available options for this selection are: **ON**, **OFF** or **LIMIT**.

- **ON** - turns the LED on when the power switch is set to ON.
- **OFF** - turns the LED off.
- **LIMIT** - turns the LED off under normal operation. The LED brief blinking indicates the limiter is activating. Short-term blinking is not critical because the integrated limiter keeps distortion under control. Constant lighting of the LED indicates the sound is negatively affected. If the LED is constantly lit, check the rear LCD for more information. Reducing the output volume is strongly recommended.

The default is **ON**.

PIN LOCK menu

The **PIN LOCK** menu locks the DSP control menu. Available options for this selection are: **OFF**, **TUNE** or **ALL**.

- **OFF** - turns the **PIN LOCK** off.
- **TUNE** - locks the **INPUT** control parameters but not the DSP control menu.
- **ALL** - locks all functions of the speaker.

The default is **OFF**.

To lock the DSP control menu:

1. Select **TUNE** or **ALL**.
2. Enter a PIN code.
3. Re-enter the PIN code to confirm.
If the PIN code does not match, it will set the **PIN LOCK** to **OFF**.
4. To lock the speaker select **LOCK NOW** from the **DISPLAY** menu.

The **PIN LOCK** will automatically engage after the speaker is power cycled.

To disable the **PIN LOCK**:

1. Deselect any input selection soft keys.
2. Push the **MASTER VOLUME** knob.
3. Using the **MASTER VOLUME** knob, scroll to **DISPLAY**.
4. Select **PIN LOCK**.
5. Select **OFF**.

If you forget the PIN code, reset the loudspeaker to default settings.

To reset the loudspeaker to default settings:

- ▶ Press and hold the soft key for **INPUT 2** and **MASTER VOLUME** knob for at least 10 seconds.
The **DEFAULT SETTINGS?** message appears.
- ▶ Select **YES**.
The **ERASE USER PRESETS?** message appears.
- ▶ Select **NO**.



DIM menu

The **DIM** menu is used to dim the display when the display is idle for 30 seconds. Available options for this selection are: **ON** or **OFF**.

The default is **ON**.

BRIGHT menu

The **BRIGHT** menu is used to determine the brightness of the LCD.
The range is 1 (darkest) to 10 (brightest).
The default is 5.

STORE menu

The **STORE** menu allows you to create up to five customized user settings. Available options for this selection are: **BACK, 1, 2, 3, 4,** and **5**.

**Notice!**

The customized user setting name can contain a combination of alphanumeric characters including spaces. The alphanumeric character range is A to Z and 0 - 9.
The name field length is 12 characters.

Storing customized user settings

To store customized user settings:

1. From the DSP control menu, scroll to **STORE**.
2. Push the **MASTER VOLUME** knob to select **STORE**.
The **STORE** screen appears.
3. Push the **MASTER VOLUME** knob to select **1**.
The **Enter name for 1** screen appears.
4. Use the **MASTER VOLUME** knob to scroll through the characters.
The characters appear.
5. Push the **MASTER VOLUME** knob to select the required character.
6. Turn the **MASTER VOLUME** knob to move to the next character entry.
Continue selecting characters until the required name is entered.
7. Use the **MASTER VOLUME** knob to scroll to **SAVE**.
8. Push the **MASTER VOLUME** knob to select **SAVE**.
9. Repeat steps 3 through 8 to store additional customized user settings.
10. Select **EXIT** to return to the home screen.

RECALL menu

The **RECALL** menu allows you to retrieve up to five customized user settings. Available options for this selection are: **BACK, 1, 2, 3, 4,** and **5**. In addition, setting **6** is available to recall a default setting. This setting cannot be used to store user settings.

Recalling customized user settings

To recall customized user settings:

1. From the DSP control menu, scroll to **RECALL**.
2. Push the **MASTER VOLUME** knob to select **RECALL**.
The **RECALL** screen appears.
3. Push the **MASTER VOLUME** knob to select **1**.
The selected item is loaded.
4. After the preset is loaded, the menu will return to the home screen.

**RESET menu**

The **RESET** menu is used to reset the loudspeaker to original factory settings. Available options for this selection are: **NO** or **YES**.



Resetting the system

To reset the system to original factory settings:

- ▶ From the DSP control menu, select **RESET**.
The **DEFAULT SETTINGS?** message appears.
- ▶ Select **YES**.
The **ERASE USER PRESETS?** message appears.
- ▶ Select **YES**.



Notice!

The **RESET** menu item is used to revert the loudspeaker to the original factory default settings.

INFO menu

The **INFO** menu is used to display the firmware version.

Refer to

- *OUTPUT list*, page 51

8 Input & Mixer operation

8.1 INPUT DSP control menu

The loudspeaker INPUT DSP control menu selections are available for the ZLX-G2 powered loudspeakers.

Refer to *INPUT list*, page 54 for the complete menu list.

To control the mixer channels:

1. Press the input selection soft key to select the input channel.
The softkey will illuminate once selected.
2. Use the **MASTER VOLUME** knob to adjust the level.
3. Press the **MASTER VOLUME** knob to enter the input channel's DSP control menu.
4. Press the input selection soft key again to deselect the input channel for control.
The soft key will no longer be illuminated.

INPUT control adjustments

Caution is advised when adjusting the **INPUT LEVEL** and EQ. Usually minor changes are sufficient to produce the best results in the overall sound.

To adjust the incoming sound:

- Set all EQ controls to **0 dB** or **FLAT**.
- Avoid setting the EQ controls to extreme positions.
- Use natural reproduction as a starting point.
- Rely on your musically trained ear.

INPUT LEVEL control

The **INPUT LEVEL** control adjusts the sensitivity of the incoming signals to the internal operation level of the mixer.

To achieve a good signal input level:

1. Set the volume (**VOL**) to **MUTE** using the **MASTER VOLUME** knob.
2. Press the input selection soft key and use the **MASTER VOLUME** knob to set the **INPUT LEVEL** to **MUTE**.
3. Connect the sound source (microphone, instrument, etc) to the selected input.
4. Start the sound source at the highest volume level to be expected. Sing or speak as loudly as possible directly (close up) into the microphone.
5. While playing the sound source or singing into the microphone:
 - Increase the **INPUT LEVEL** by selecting the input channel using the input selection soft key and using the **MASTER VOLUME** knob, so that during the loudest part, the **PEAK (PK)** does not show. Press the input selection soft key again to deselect the input channel.
 - Increase the **MASTER VOLUME** until you get the required output from the loudspeaker.
This is the basic channel setting.

If further adjustments to the EQ setting of the channel are necessary, perform these steps again. Changes in the sound shaping section also have an influence on the overall level of the channel.

24V (INPUT 1 only)

+24V DC phantom power is available on the XLR connector of **INPUT 1** only. Phantom power can be used to power certain devices such as DI boxes and condenser microphones (non-electret). Consult the user manual of your device before using. There is no phantom power on the TRS connectors. Phantom power is switchable.

**Notice!**

Switch off phantom power (default) for sources which do not require phantom power such as dynamic microphones and mixer outputs.

**Notice!**

Never connect a mobile device to **INPUT 1** with phantom power activated.

PRESET

The input **PRESET** adjusts the EQ and compressor settings to provide a starting point for adjusting the sound for different input types.

COMP control

The **COMP** control controls the onboard compressor to adjust the input signal processing during operation. Compressors are available on **INPUT 1** and **INPUT 2**.

- ▶ Use the **COMP** control to adjust the compressor threshold and the compression ratio simultaneously.

Adjusting the **COMP** control from 0 to 100 will result in the following:

- The gain below the threshold will increase from 0 dB to +6 dB.
- The compression ratio will increase from 1:1 to 8:1.
- The compressor will reduce the dynamic range of the audio signal proportional to the compressor setting.

Once the signal exceeds a certain threshold, the signal gets compressed. Major input level changes result in minor output level changes. Narrowing the dynamic range often allows for easier recording or mixing of the audio signal. It is recommended to start with low to moderate levels of compression (25 - 40) and increase slowly if necessary.

TREBLE/MID/BASS controls

The EQ section of the input channel allows for a broad difference in the shaping of the incoming audio signal within three frequency bands:

- **TREBLE** control - provides cymbals and vocals with more treble for a more transparent sound.
- **MID** control - increasing this level provides higher output in the vocal range, reducing this level can help reduce acoustical feedback.
- **BASS** control - adds more “punch” to the sound of a kick drum or adds “body” to the vocals.

FX

The **FX** control is used to set the amount of effect you require on that channel. Using the **FX** controls lets you easily assign an effect for musical instruments or vocals.

To determine the required level of effect:

1. Set the controls to minimum.

2. Increase the level individually and gradually until the required sound is achieved.

PAN/BAL

The **PAN** (mono inputs) or **BAL** (stereo inputs) control adjusts the amount of the signal coming out of the stereo L or stereo R loudspeaker in a stereo setup. The **PAN/BAL** is not engaged for mono (single loudspeaker) setups.

DUCKER

The **DUCKER** reduces the level of the signal(s) on the other inputs whenever a signal is detected at the selected MIC/LINE input (**INPUT 1** or **INPUT 2**). If no signal is detected at the selected MIC/LINE input, the level of the signal(s) on the other inputs will return to the previous set levels.

The **DUCKER** is useful to speak over background music:

- When signal is detected on the selected MIC input, the music on the other input channel will be reduced.
- When signal is no longer detected on the selected MIC input, the music will return to the previous level.

Engaging the DUCKER

To engage the ducker:

1. Select **INPUT 1** and/or **INPUT 2**.
2. Adjust the **DUCKER** level to set the detection threshold for the selected input channel. When signal is detected on the selected input, the signal on the other inputs will be reduced by 12 dB. Typical values are -10 to -20 dB.

The table below describes the **DUCKER** operation logic. The **DUCKER** setting is the detection threshold selected on **INPUT 1** and/or **INPUT 2**. The ducked channels are the input signals that are reduced by 12 dB.

	INPUT 1	INPUT 2	Reduced channels
DUCKER SETTING	-1 dB - -40 dB	OFF	INPUTS 2 & BT
	OFF	-1 dB - -40 dB	INPUTS 1 & BT
	-1 dB - -40 dB	-1 dB - -40 dB	INPUT BT
	OFF	OFF	NONE

Refer to

- *INPUT list, page 54*

9 Recommended configurations

9.1 Powered loudspeakers

9.1.1 Connecting with mobile device

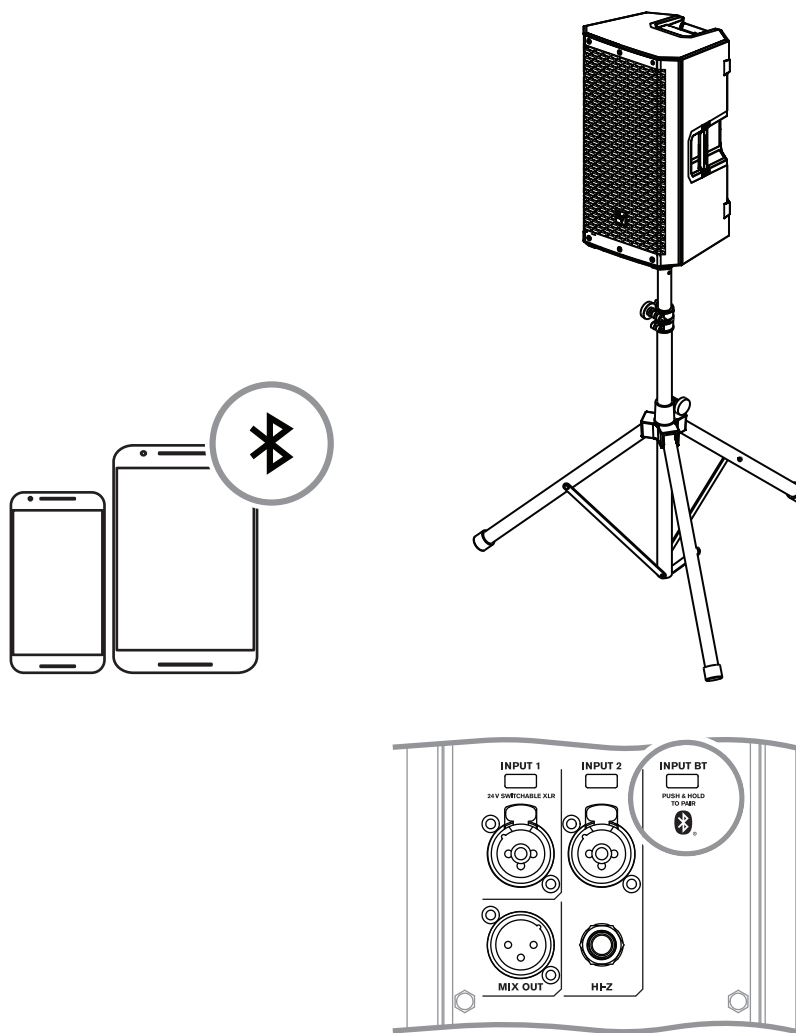

Notice!

The direction of the arrow indicates the signal path.

MODE	MUSIC
LOCATION	TRIPOD
SUB	OFF

Table 9.1: DSP settings loudspeaker on a tripod

9.1.2 Street musician performance

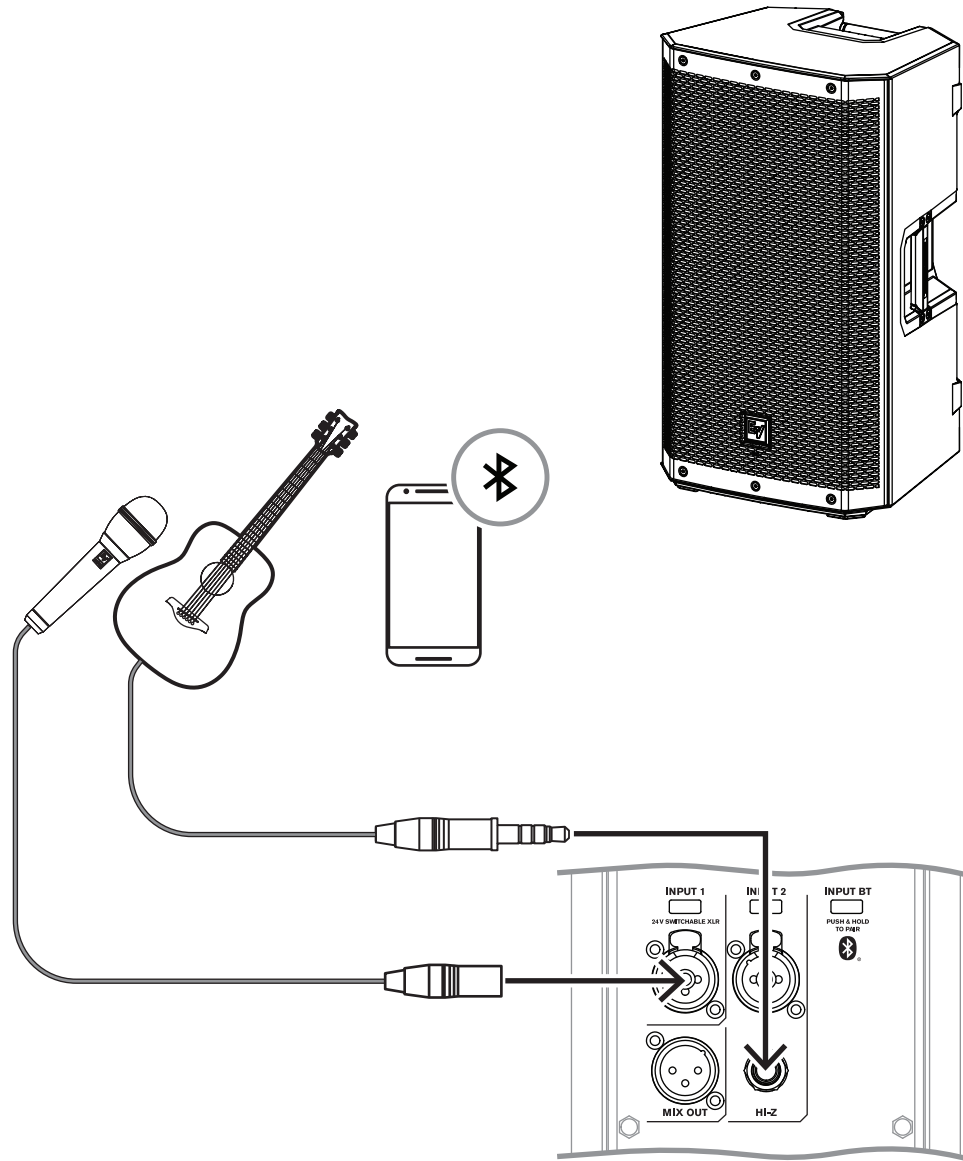

Notice!

The direction of the arrow indicates the signal path.

MODE	LIVE
LOCATION	KICKBACK
SUB	OFF

INPUT 1 PRESET	VOCAL MIC
INPUT 2 PRESET	ACOUSTIC GTR

Table 9.2: DSP settings loudspeaker in kickback position

9.1.3 Bluetooth true wireless stereo (TWS)

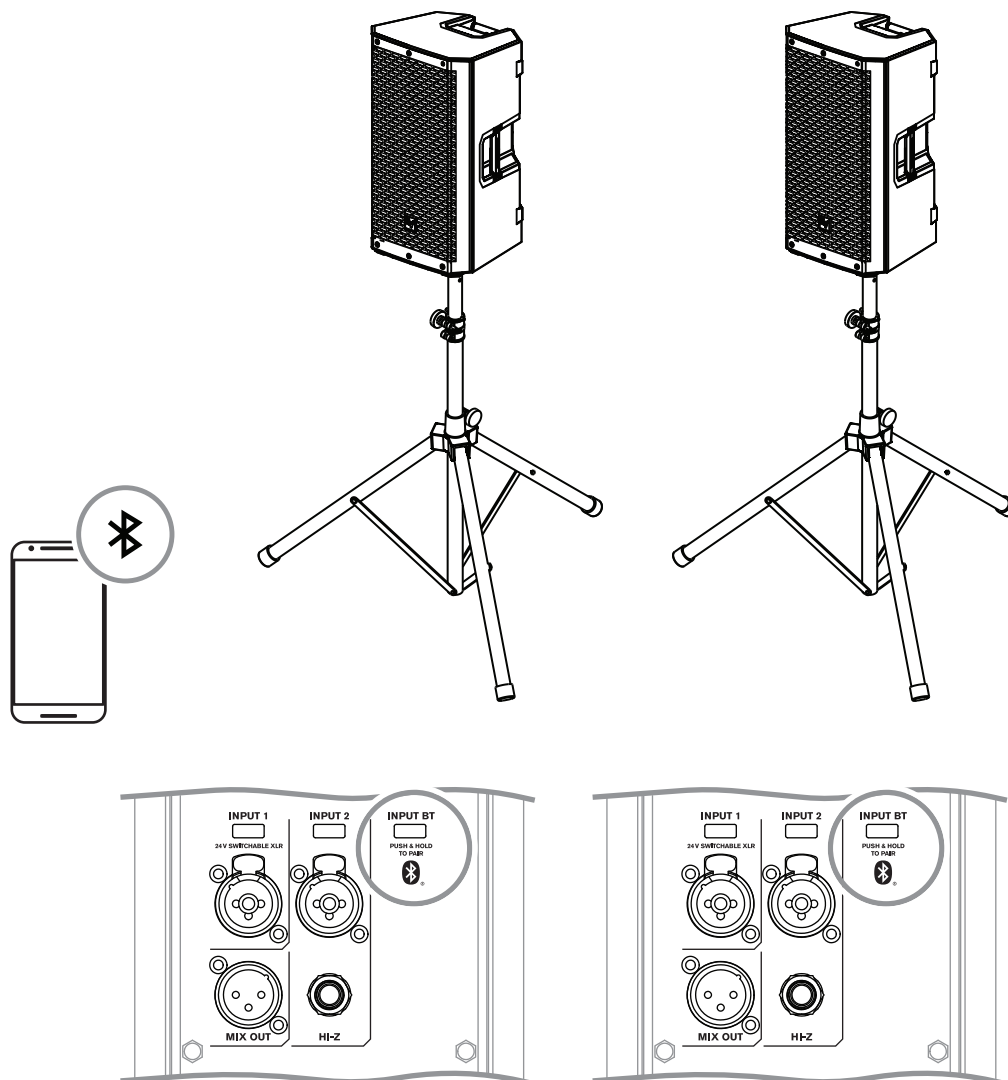

MODE	MUSIC
LOCATION	TRIPOD
SUB	OFF
INPUT PRESET	NONE

Table 9.3: DSP settings loudspeaker on a tripod

To connect two loudspeakers via TWS:

1. Connect one of the loudspeakers to your streaming device via Bluetooth®.

2. Select **LINK SPEAKERS** in the **BLUETOOTH** control menu on both loudspeakers.

9.1.4 Using as monitor

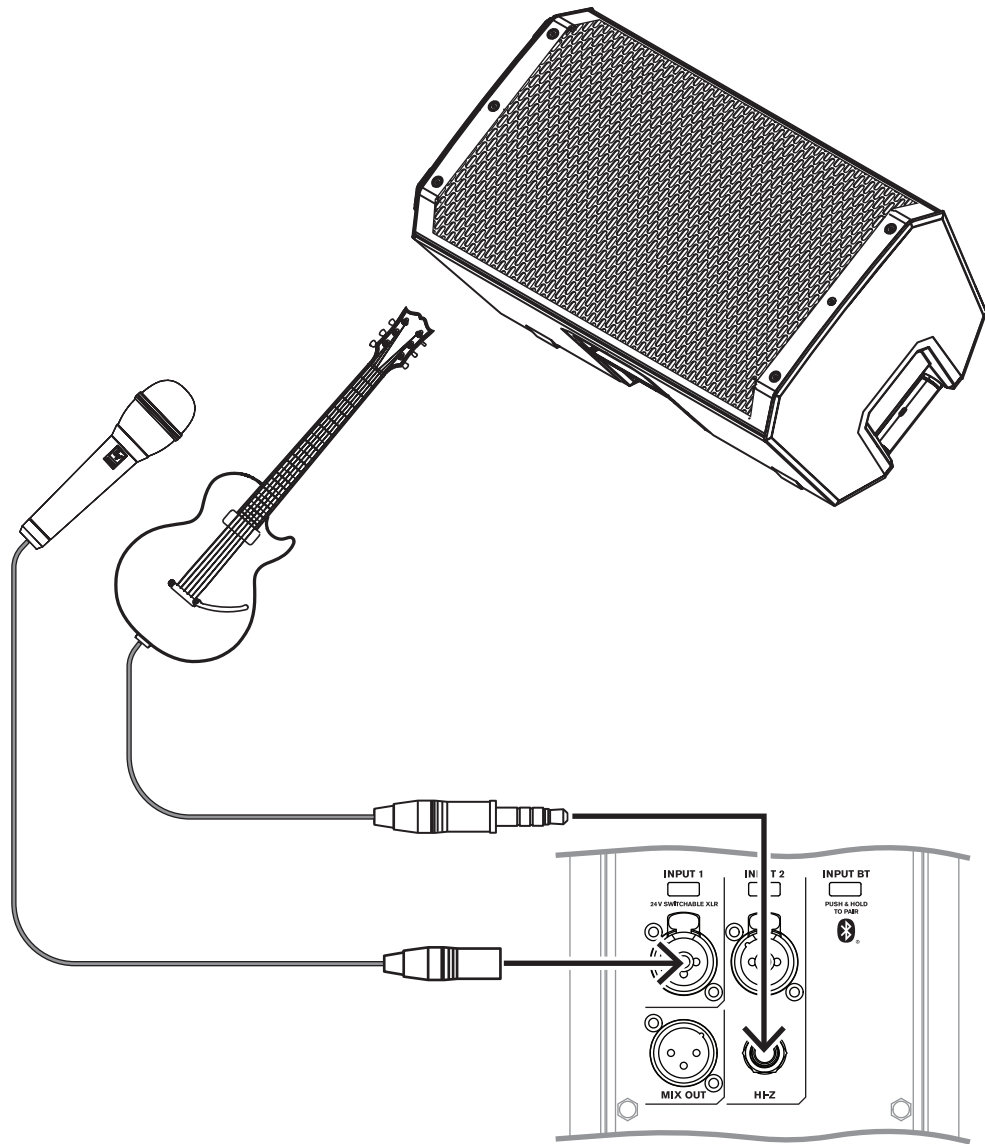

Notice!

The direction of the arrow indicates the signal path.

MODE	LIVE
LOCATION	MONITOR
SUB	OFF
INPUT 1 PRESET	VOCAL MIC
INPUT 2 PRESET	ELECTR GUIT

Table 9.4: DSP settings loudspeakers as monitors

9.1.5 Daisy-chaining full-range systems

LINE and MIC input level control is available for both INPUT 1 and INPUT 2.

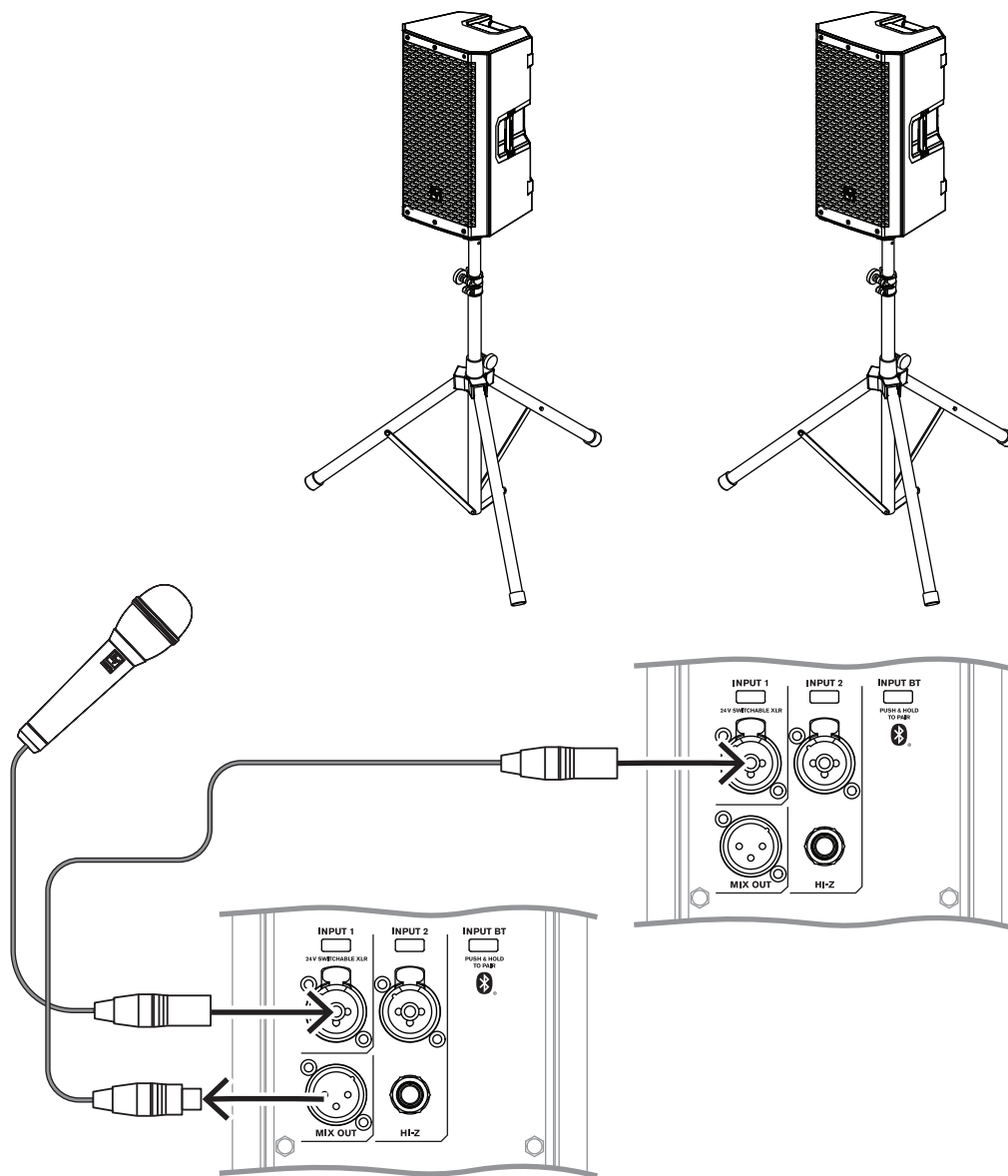

Notice!

The direction of the arrow indicates the signal path.

Mode:	Speech
Location:	Pole
Sub:	Off

Table 9.5: DSP settings loudspeaker on a tripod

9.1.6 Stacking full-range systems with subwoofers

The configuration includes:

- ZLX-8P-G2, ZLX-12P-G2, or ZLX-15P-G2 loudspeakers.
- ELX200-18SP subwoofer.

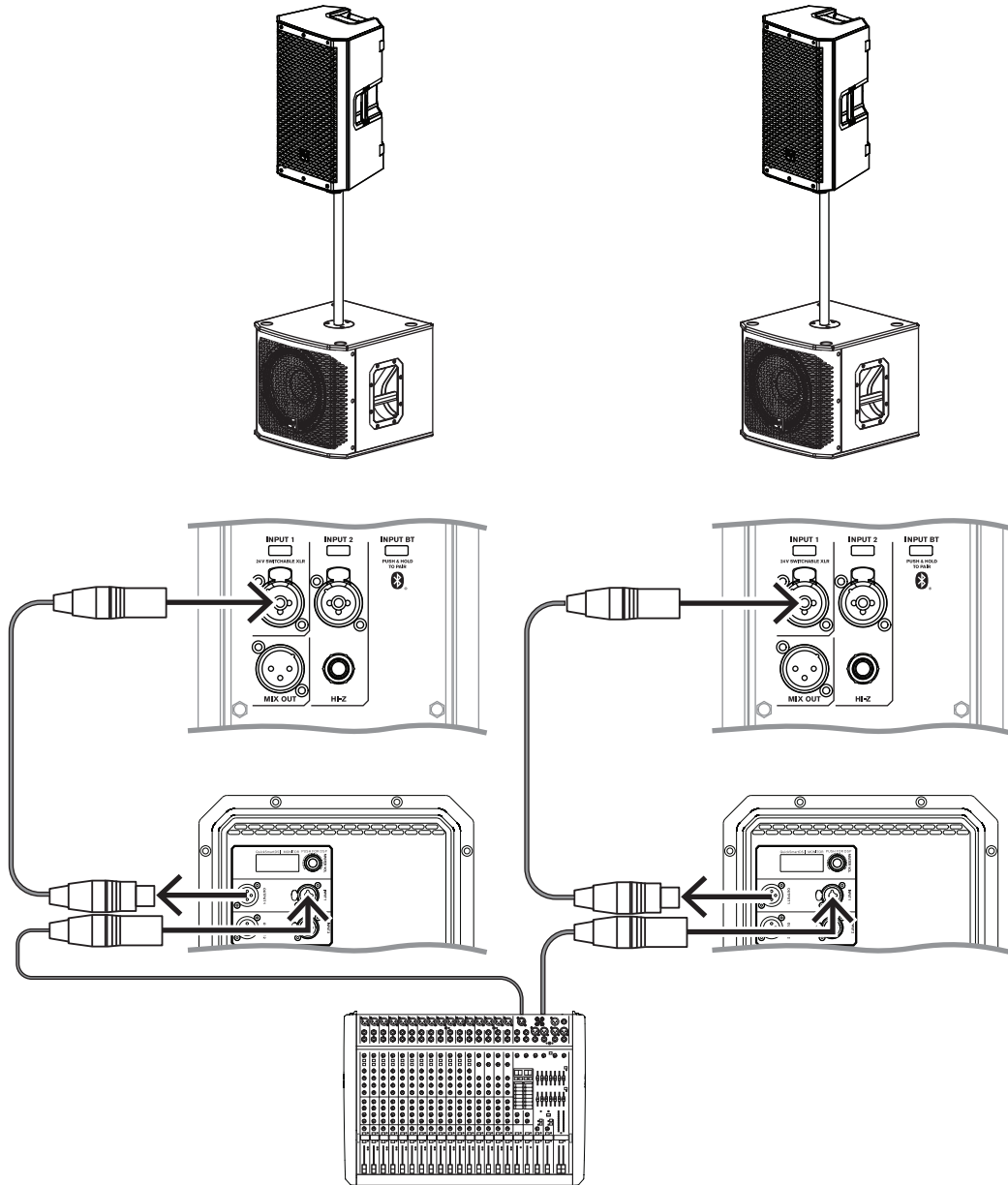

Notice!

The direction of the arrow indicates the signal path.

	ZLX-12P-G2	ELX200-18SP
Mode:	Live	Live
Location:	Pole	n/a
Sub:	ELX200-18SP	n/a

	ZLX-12P-G2	ELX200-18SP
Low Pass:	n/a	ZLX-12P-G2

Table 9.6: DSP settings loudspeaker and subwoofer stacked

9.2 Passive loudspeakers



Caution!

For optimal acoustics and performance, we recommend using the ZLX-G2 with a Dynacord DSP power amplifier, programmed with the appropriate speaker settings included in the EV Speaker Database for SONICUE. Failure to use the proper amplifier and speaker settings may result in poor acoustic performance, cause permanent damage, and void of warranty.

9.2.1 Basic stereo system using full-range systems

The configuration includes:

- ZLX-8-G2, ZLX-12-G2 or ZLX-15-G2 loudspeakers.
- Dynacord L1800FD amplifier programmed with the appropriate speaker settings from SONICUE.

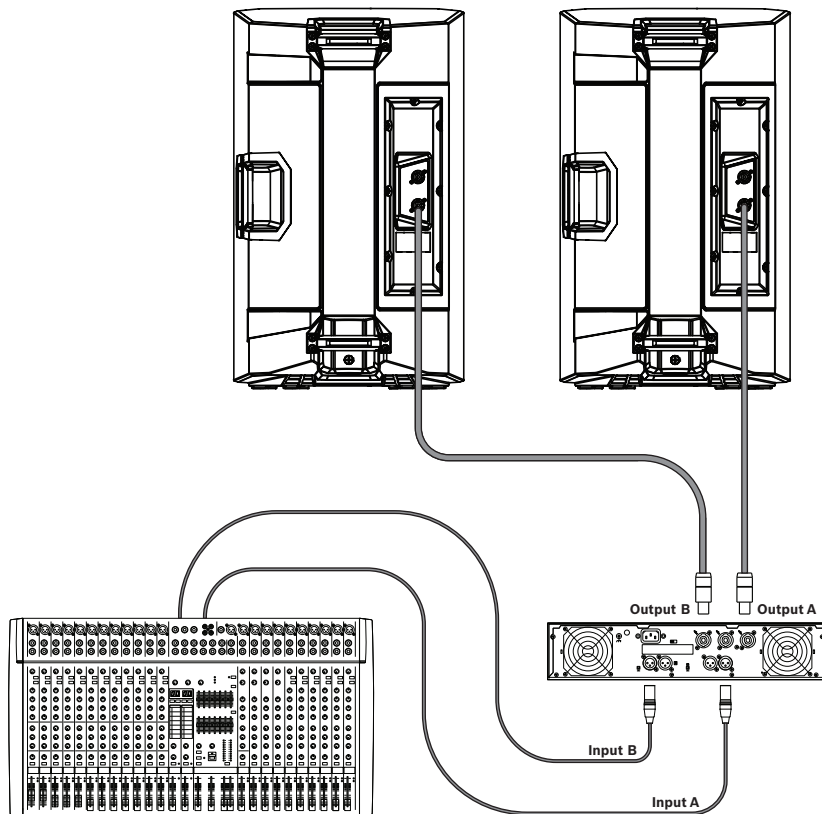

NL4 Pin Configuration	
Pin 1+ and 1-	Used
Pin 2+ and 2-	Not used (pass-through)



Caution!

Do not exceed the maximum load rating of the amplifier.

Amplifier Load (per Output Channel)		
# of Speakers	Nominal	Minimum
1	8 Ohms	7.2 Ohms
2	4 Ohms	3.6 Ohms
3	2.7 Ohms	2.4 Ohms
4	2 Ohms	1.8 Ohms

9.2.2

Using full-range systems as stage monitors

The configuration includes:

- Multiple ZLX-8-G2, ZLX-12-G2 or ZLX-15-G2 loudspeakers in monitor position.
- Dynacord L1800FD amplifier programmed with the appropriate speaker settings from SONICUE.

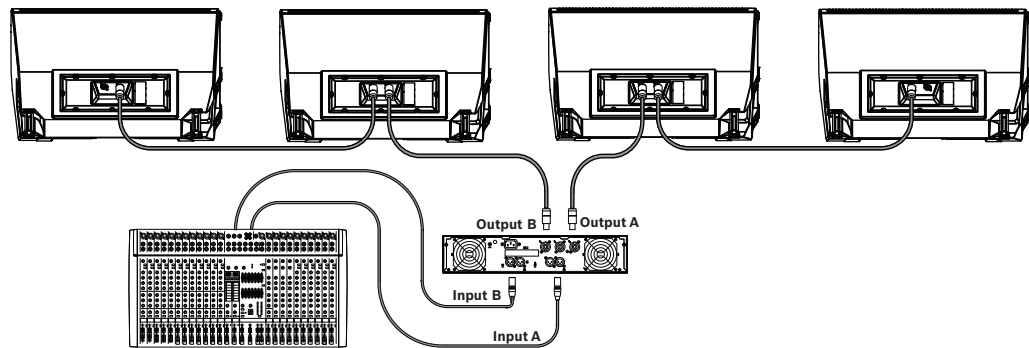

NL4 Pin Configuration	
Pin 1+ and 1-	Used
Pin 2+ and 2-	Not used



Caution!

Do not exceed the maximum load rating of the amplifier.

Amplifier Load (per Output Channel)		
# of Speakers	Nominal	Minimum
1	8 Ohms	7.2 Ohms
2	4 Ohms	3.6 Ohms
3	2.7 Ohms	2.4 Ohms
4	2 Ohms	1.8 Ohms

9.2.3 Stacking full-range systems with subwoofers

Possible configurations:

- ZLX-12-G2 loudspeaker with EKX-15S subwoofer.
- Dynacord L1800FD amplifier with 35 Hz high pass filter from mixer or processor.

OR

- ZLX-15-G2 loudspeaker with EKX-18S subwoofer.
- Dynacord L1800FD amplifier with 30 Hz high pass filter from mixer or processor.

This configuration allows a user to increase the low frequency performance without using additional amplifier channels.

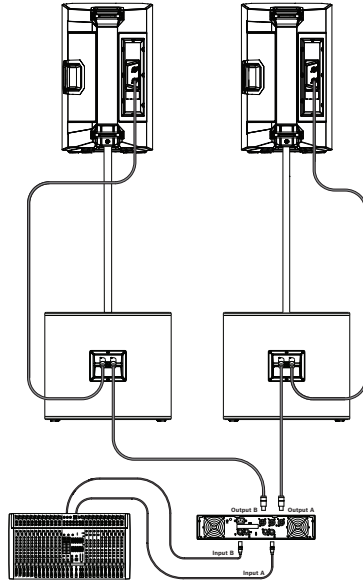

NL4 Pin Configuration	
Pin 1+ and 1-	Used
Pin 2+ and 2-	Not used (pass-through)



Caution!

Do not exceed the maximum load rating of the amplifier.

Amplifier Load (per Output Channel)		
# of Subwoofer/Full-Range Combinations	Nominal	Minimum
1	4 Ohms	3.8 Ohms
2	2 Ohms	1.9 Ohms

10 Troubleshooting

10.1 Passive loudspeakers

Problem	Possible Cause(s)	Action
1. No sound	Amplifier	Verify all the electronics are on, the signal routing is correct, the source is active; the volume is turned up, etc. Correct/repair/replace as necessary. If there is still no sound, then the problem may be wiring.
	Wiring	Verify you have connected the correct cables to the amplifier. Play something at a low level through the amplifier. Connect a test loudspeaker in parallel with the malfunctioning line. If the sound level is gone or is very weak, the line has a short in it (possibly a severe scrape, pinch, or a missed connection). Using the test loudspeaker, move down the line and test each connection/junction until you find the problem and correct it. Observe proper polarity.
	Sources not connected	Check all cables between the source and the loudspeaker with a multimeter or cable tester. Replace any suspect cables with a known good cable.
2. Poor Low-Frequency Response	Loudspeakers wired out-of-polarity	When two loudspeakers are connected out of polarity, the low frequencies will cancel each other acoustically. Carefully observe the wire markings or tracers on your loudspeaker wires. Verify the amplifier (+) terminal is connected to pin 1+ of the NL4 connector and the amplifier (-) terminal is connected to pin 1-of the NL4 connector.
3. Intermittent output such as cracking or distortion	Faulty connection	Check all connections at amplifier and loudspeaker to ensure they are all clean and tight. If the problem persists, check the wiring. See problem 1.
4. Constant noise such as buzzing, hissing or humming	Defective source or other electronic device	If noise is present, but no program material is playing, evaluate each component as necessary to isolate the problem. Most likely there is a break in the signal path.
	Poor system grounding or ground loop	Check and correct the system grounding, as required.
5. Microphone produces acoustic feedback when INPUT LEVEL is amplified	Microphone position is too close to the front of the loudspeaker	Whenever possible setup the loudspeakers so the microphone is behind them. If using the loudspeaker in a monitor position, aim the loudspeaker to the back of the microphone.
If these suggestions do not solve your problem, contact your nearest Electro-Voice dealer or Electro-Voice distributor.		

10.2 Powered loudspeakers

Problem	Possible Cause(s)	Action
6. No sound	Amplifier	Verify all the electronics are on, the signal routing is correct, the source is active; the volume is turned up, etc. Correct/repair/replace as necessary. If there is still no sound, then the problem may be wiring.
	Wiring	Verify you have connected the correct cables to the amplifier. Play something at a low level through the amplifier. Connect a test loudspeaker in parallel with the malfunctioning line. If the sound level is gone or is very weak, the line has a short in it (possibly a severe scrape, pinch, or a missed connection). Using the test loudspeaker, move down the line and test each connection/junction until you find the problem and correct it. Observe proper polarity.
	Improper gain	Verify all the sources are on. If the source is a condenser microphone, make sure the mic is plugged into INPUT 1 via XLR and phantom power is enabled in the menu. Inspect the VU meters on LCD or in the app. If there is signal present on the VU meters, increase the input and gain controls to the required level. If there is no signal present on the VU meters, then check the wiring.
	Sources not connected	Check all cables between the source and the loudspeaker with a multimeter or cable tester. Replace any suspect cables with a known good cable.
7. Poor Low-Frequency Response	With SUB menu cross-over frequency activated	If no subwoofers are used with the system, select the OFF position.
	SPEECH mode is active	In the DSP control menu, change the MODE to MUSIC , LIVE , or CLUB . Refer to DSP controls for more details.
	Input PRESET is not set to FLAT	In the INPUT DSP control menu, change PRESET to FLAT . Refer to INPUT DSP control menu for more details.
	EQ is active	In the INPUT and DSP control menu, reset all EQs in the low frequencies. Refer to DSP controls and INPUT DSP control menu for more details.
8. Intermittent output such as cracking or distortion	Faulty connection	Check all connections at amplifier and loudspeaker to ensure they are all clean and tight. If the problem persists, check the wiring. See problem 1.
9. Constant noise such as buzzing, hissing or humming	Defective source or other electronic device	If noise is present, but no program material is playing, evaluate each component as necessary to isolate the problem. Most likely there is a break in the signal path.
	Poor system grounding or ground loop	Check and correct the system grounding, as required.

Problem	Possible Cause(s)	Action
	Input gain is not at a microphone level.	Slowly increase the INPUT LEVEL to engage the microphone pre-amp.
	Mobile device is connected via USB and 3.5 mm jack simultaneously.	Some mobile devices, such as laptops and mobile phones, may introduce ground loops if the loudspeaker is charging the mobile device while simultaneously connected via the 3.5 mm audio input jack. Connect the audio via Bluetooth®, or disconnect from the USB jack.
10. No sound produced with microphone connected to INPUT 1 or INPUT 2	Microphone requires phantom power.	Use a dynamic microphone that does not require phantom power. If using a microphone requiring phantom power, connect it to INPUT 1 via the XLR connector and enable phantom power. Refer to INPUT DSP control menu for more details.
	Input gain is too low	Slowly increase the input gain knob level to engage the microphone pre-amp.
11. Sound is distorted, front LED is OFF , LCD screen LIMIT is ON	Excessive INPUT LEVEL	Reduce the INPUT LEVEL or loudspeaker level knobs to prevent limit.
	Incorrect gain structure or source input (mixing console/preamp) is overdriven	Verify level controls of the source are properly structured by using the VU meter indicator on the LCD screen. If the VU meter bar is solid or the system indicates LIMIT , the input or source level is too high.
12. Microphone produces acoustic feedback when INPUT LEVEL is amplified	Automatic Feedback Suppression is OFF	Enable Automatic Feedback Suppression in the DSP Control menu. Refer to DSP controls for more details.
	Incorrect gain structure	Reduce the microphone levels at the mixing console or input source. If the microphone is connected directly to the loudspeaker, reduce the INPUT LEVEL on the loudspeaker. Positioning the microphone close to the sound source increases gain-before-feedback. See problem 6.
	MODE is set to MUSIC	Change the MODE to LIVE or SPEECH .
	Microphone position is too close to the front of the loudspeaker	Whenever possible setup the loudspeakers so the microphone is behind them. If using the loudspeaker in a monitor position, aim the loudspeaker to the back of the microphone.
13. DSP control menu is locked	The menu LOCK function has been turned on. A lock symbol displays on the LCD screen.	Press the MASTER VOLUME knob or input selection soft keys to unlock.
14. QuickSmart Mobile app does not detect the loudspeaker	Enable Bluetooth®	Ensure Bluetooth® is enabled on the loudspeaker. For Android: ensure location services are activated. Remove loudspeaker from iOS/Android in device settings (sometimes called "FORGET"). Restart pairing. Ensure phone/tablet has required OS version and latest

Problem	Possible Cause(s)	Action
		updates installed. Ensure the latest QuickSmart Mobile App is installed. Ensure no other phone/tablet is connected to the same loudspeaker.
15. PIN code unlock not successful	Incorrect PIN code entered	Retry PIN code entry Or Press and hold the soft key for INPUT 2 and MASTER VOLUME knob for at least 10 seconds to reset the loudspeaker to default settings.
If these suggestions do not solve your problem, contact your nearest Electro-Voice dealer or Electro-Voice distributor.		

11 Technical data

11.1 Powered loudspeakers

- 1) Full space measurement using music DSP preset.
 2) Half-space measurement.
 3) Maximum SPL is measured at 1 m using broadband pink noise at maximum output.
 4) Current rating is 1/8 power.

	ZLX-8P-G2-EU 8" 2-way powered speaker, EU cord ZLX-8P-G2-US 8" 2-way powered speaker, US cord	ZLX-12P-G2-EU 12" 2-way powered speaker, EU cord ZLX-12P-G2-US 12" 2-way powered speaker, US cord	ZLX-15P-G2-EU 15" 2-way powered speaker, EU cord ZLX-15P-G2-US 15" 2-way powered speaker, US cord
Frequency response (-3 dB) (Hz) ¹	58 Hz – 20,000 Hz	54 Hz – 18,500 Hz	48 Hz – 18,000 Hz
Frequency range (-10 dB) (Hz) ^{1,2}	50 Hz – 20,000 Hz	48 Hz – 20,000 Hz	42 Hz – 20,000 Hz
Maximum sound pressure level at a distance of 1 m (dB) ³	126 dB	127 dB	129 dB
Coverage angle HxV (°)	90° x 60°	90° x 60°	90° x 60°
Crossover frequency (kHz)	1.40 kHz	1.40 kHz	1.40 kHz
Power rating (W)	1000 W	1000 W	1000 W
Power consumption (V, Hz) ⁴	100 - 240 V~, 0.8 - 0.5 A, 50 - 60 Hz	100 - 240 V~, 0.8 - 0.5 A, 50 - 60 Hz	100 - 240 V~, 0.8 - 0.5 A, 50 - 60 Hz
LF transducer	WECA2088	WECA2128	WECA2158
LF transducer size (in)	8 in	12 in	15 in
LF transducer magnet material	Ferrite	Ferrite	Ferrite
HF transducer	DECA2516	DECA2516	DECA2516
HF transducer type	Compression driver	Compression driver	Compression driver
HF transducer size (in)	1.40 in	1.40 in	1.40 in
HF transducer magnet material	Ferrite	Ferrite	Ferrite
HF transducer diaphragm material	Titanium	Titanium	Titanium
Connector type	(2) XLR/TRS combo, (1) ¼-inch TS Hi-Z	(2) XLR/TRS combo, (1) ¼-inch TS Hi-Z	(2) XLR/TRS combo, (1) ¼-inch TS Hi-Z
Material	Polypropylene	Polypropylene	Polypropylene
Grille material	Powder coated steel	Powder coated steel	Powder coated steel
Dimensions (H x W x D) (mm)	459.6 mm x 289.9 mm x 280.5 mm	621.1 mm x 356.2 mm x 356 mm	697.6 mm x 422.8 mm x 383.1 mm

	ZLX-8P-G2-EU 8" 2-way powered speaker, EU cord ZLX-8P-G2-US 8" 2-way powered speaker, US cord	ZLX-12P-G2-EU 12" 2-way powered speaker, EU cord ZLX-12P-G2-US 12" 2-way powered speaker, US cord	ZLX-15P-G2-EU 15" 2-way powered speaker, EU cord ZLX-15P-G2-US 15" 2-way powered speaker, US cord
Dimensions (H x W x D) (in)	18.09 in x 11.41 in x 11.04 in	24.45 in x 14.02 in x 14.01 in	27.46 in x 16.65 in x 15.08 in
Shipping dimensions (H x W x D) (mm)	500 mm x 390 mm x 350 mm	670 mm x 420 mm x 405 mm	765 mm x 490 mm x 490 mm
Shipping dimensions (H x W x D) (in)	19.69 in x 15.35 in x 13.78 in	26.38 in x 16.54 in x 15.94 in	30.12 in x 19.29 in x 19.29 in
Weight (kg)	10.64 kg	14.82 kg	16.78 kg
Weight (lb)	23.46 lb	32.67 lb	37 lb
Shipping weight (kg)	12.58 kg	16.86 kg	19.64 kg
Shipping weight (lb)	27.73 lb	37.17 lb	43.30 lb

11.2

Passive loudspeakers

1) With recommended preset

	ZLX-8-G2 8" 2-way passive speaker	ZLX-12-G2 12" 2-way passive speaker	ZLX-15-G2 15" 2-way passive speaker
Frequency response (-3 dB) (Hz) ¹	67 Hz – 20,000 Hz	69 Hz – 18,500 Hz	68 Hz – 18,000 Hz
Frequency range (-10 dB) (Hz) ¹	55 Hz – 20,000 Hz	55 Hz – 20,000 Hz	53 Hz – 20,000 Hz
Axial sensitivity (dB SPL 1W/1m)	90 dB SPL 1W/1m	93 dB SPL 1W/1m	95 dB SPL 1W/1m
Maximum sound pressure level at a distance of 1 m (dB) ¹	124 dB	125 dB	126 dB
High pass frequency (Hz)	60 Hz	48 Hz	40 Hz
Crossover frequency (kHz)	2 kHz	2 kHz	2 kHz
Coverage angle HxV (°)	90° x 60°	90° x 60°	90° x 60°
Power handling (continuous) (W)	250 W	250 W	250 W
Power handling (peak) (W)	1000 W	1000 W	1000 W
Nominal impedance (Ω)	8 Ω	8 Ω	8 Ω
LF transducer	WECA2088	WECA2128	WECA2158

	ZLX-8-G2 8" 2-way passive speaker	ZLX-12-G2 12" 2-way passive speaker	ZLX-15-G2 15" 2-way passive speaker
LF transducer size (in)	8 in	12 in	15 in
LF transducer magnet material	Ferrite	Ferrite	Ferrite
HF transducer	DH-1K	DH-1K	DH-1K
HF transducer type	Compression driver	Compression driver	Compression driver
HF transducer size (in)	1.40 in	1.40 in	1.40 in
HF transducer diaphragm material	Titanium	Titanium	Titanium
Dimensions (H x W x D) (mm)	459.6 mm x 289.9 mm x 280.5 mm	621.1 mm x 356.2 mm x 356 mm	697.6 mm x 422.8 mm x 383.1 mm
Dimensions (H x W x D) (in)	18.09 in x 11.41 in x 11.04 in	24.45 in x 14.02 in x 14.01 in	27.46 in x 16.65 in x 15.08 in
Shipping dimensions (H x W x D) (mm)	500 mm x 390 mm x 350 mm	670 mm x 420 mm x 405 mm	765 mm x 490 mm x 490 mm
Shipping dimensions (H x W x D) (in)	19.69 in x 15.35 in x 13.78 in	26.38 in x 16.54 in x 15.94 in	30.12 in x 19.29 in x 19.29 in
Weight (kg)	10.15 kg	14.26 kg	16.44 kg
Weight (lb)	22.38 lb	31.44 lb	36.24 lb
Shipping weight (kg)	11.92 kg	16.26 kg	19.18 kg
Shipping weight (lb)	26.28 lb	35.85 lb	42.28 lb

11.3

Dimensions

8-inch models

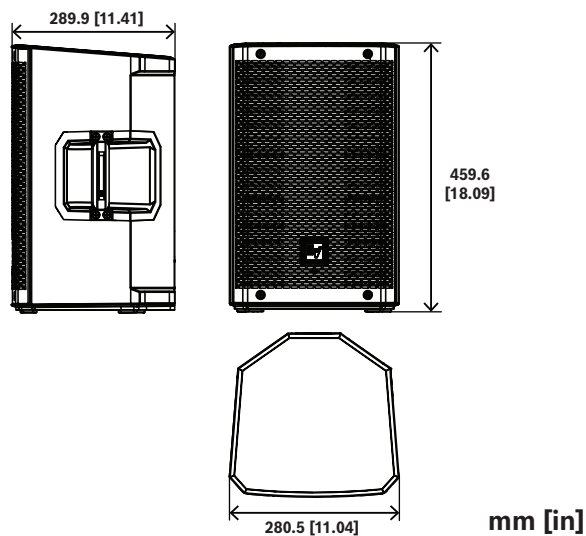

12-inch models

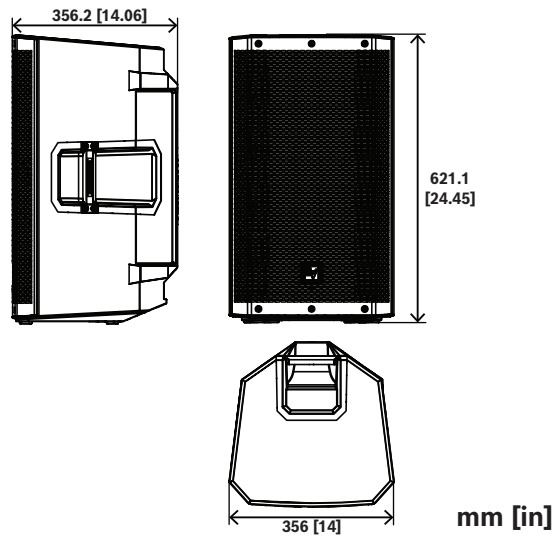

15-inch models

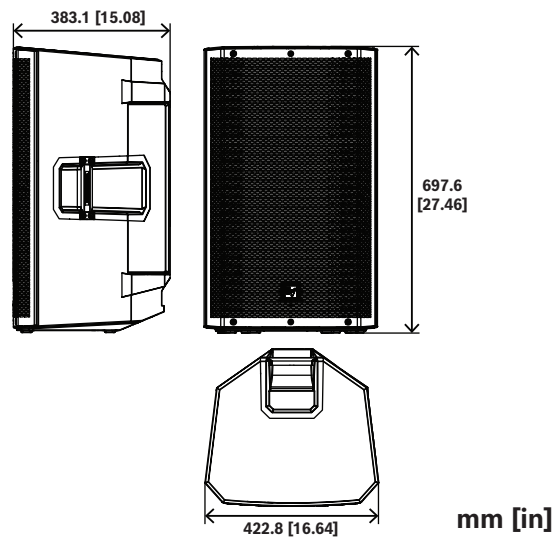

12 Appendices

12.1 Warranty information

For information on warranty periods and after sales service, please visit: www.electrovoice.com/warranty

12.2 Effects (FX) list

Note: Subject to change without notice

Number	Name App	Name LCD
0	OFF	OFF
1	Echo+ReverbShort	ECHO+REVERB S
2	Reverb Room	REV ROOM
3	Reverb Concert Hall	REV CONCERT
4	Reverb Large Hall	REV HALL
5	Reverb Church	REV CHURCH
6	Reverb Room Soft	REV ROOM S
7	Reverb Concert Hall Soft	REV CONCERT S
8	Reverb Large Hall Soft	REV HALL S
9	Reverb Church Soft	REV CHURCH S
10	Reverb Cathedral Soft	REV CATHEDRAL S
11	Reverb Plate Medium	PLATE MEDIUM
12	Reverb Plate Long	PLATE LONG
13	Reverb Plate Medium Soft	PLATE MEDIUM S
14	Reverb Plate Long Soft	PLATE LONG S
15	Reverb+ChorusSlow	REV+CHORUS SLOW
16	Reverb+ChorusMedium	REV+CHORUS MEDIUM
17	Reverb+ChorusFast	REV+CHORUS FAST
18	Delay Short	DELAY SHORT
19	Delay Long	DELAY LONG
20	Delay Tap	DELAY TAP
21	Chorus Slow	CHORUS SLOW
22	Chorus Medium	CHORUS MEDIUM
23	Chorus Fast	CHORUS FAST
24	Chorus+Echo Slow	CHORUS+ECHO S
25	Chorus+EchoMedium	CHORUS+ECHO M
26	Chorus+Echo Fast	CHORUS+ECHO F

Number	Name App	Name LCD
27	Slap Back+EchoSlow	SLAPBACK+ECHO S
28	Slap Back+EchoFast	SLAPBACK+ECHO F
29	Doubling Narrow	DOUBLING NARROW
30	Doubling Wide	DOUBLING WIDE

12.3 OUTPUT list

VOLUME			0 dB (Default)	
			MUTE, -80 dB- +10 dB, (1 dB)	
	EXIT			
	MODE			MUSIC (Default)
				LIVE
				SPEECH
				CLUB
				FRFR-GUITAR
	LOCATION			TRIPOD (Default)
				KICKBACK (12- and 15-inch models)
				MONITOR
				WALL
	SUB			OFF (Default)
				80 Hz
				100 Hz
				120 Hz
				150 Hz
				ELX200-12SP
				ELX200-18SP
				EKX-15SP
			EKX-18SP	
	DELAY	BACK		
			DELAY	OFF (Default)
				0.1 m - 100.0 m 0.3 - 328.2 ft 0.3 - 291.4 ms

	UNIT	METER (Default)
		FEET
		MILLISECONDS
	BACK	
TREBLE		0 dB (Default)
		-12 dB - +6 dB
MID		0 dB (Default)
		-12 dB - +6 dB
BASS		0 dB (Default)
		-12 dB - +6 dB
MAIN EQ (PEQ selected)	BACK	
	ENABLE ALL	ON (Default)
		OFF
	RESET ALL	NO (Default)
		YES
	PEQ #	1 (Default)
		1 - 7
	BYPASS	OFF (Default)
		ON
	TYPE	PEQ (Default)
		LOW SHELF
		HI SHELF
		LOW PASS
		HI PASS
	Q (PEQ only)	0.7 (Default)
		0.5 - 10.0
	FREQ	120 Hz (Default)
50 Hz - 20 kHz		
GAIN (PEQ, LOW SHELF and HI SHELF only)	0 dB (Default)	
	-12 dB - +6 dB	
RESET	NO (Default)	
	YES	
BACK		

MAIN EQ (GEQ selected)	BACK		
	63 Hz	0 dB (Default) -12 dB - +12 dB (1 dB)	
	160 Hz	0 dB (Default)	
	400 Hz	-12 dB - +12 dB (1 dB)	
	1 kHz	0 dB (Default)	
	2.5 kHz	-12 dB - +12 dB (1 dB)	
	6 kHz	0 dB (Default)	
	12 kHz	-12 dB - +12 dB (1 dB)	
	RESET	RESET ALL BANDS? YES/NO	
	BACK		
FX	01 (Default)		
	00 to 30		
FX Delay (FX 20: DELAY TAP only)	30 ms (Default)		
	30 ms - 550 ms		
FX ENABLE	ON (Default)		
	OFF		
AFS (automatic feedback suppression)	OFF (Default)		
	ON		
MIX OUT	L + R (Default)		
	L		
	R		
BLUETOOTH	BACK		
	BLUETOOTH	ON (Default)	
		OFF	
	ID (4-digit unique device number)		
	CONTROL PAIR		
	AUDIO PAIR		
	LINK SPEAKERS		
	LINK ROUTE	L + R (Default)	
		L	
		R	
BACK			
LED	ON (Default)		

		OFF
		LIMIT
DISPLAY	BACK	
	PIN LOCK	OFF
		TUNE
		ALL
	LOCK NOW (only if PIN is set)	
	DIM	30 s (Default)
		10 s - 60 s
		OFF
	BRIGHT	5 (Default)
		1 - 10
BACK		
STORE		BACK, 1, 2, 3, 4, 5, BACK
RECALL		BACK, 1, 2, 3, 4, 5, 6 (Default), BACK
RESET	DEFAULT SETTINGS?	NO (Default)
		YES
	ERASE USER PRESETS?	NO (Default)
		YES
IMPRINT & LICENSE		[OSS license text]
INFO		[FIRMWARE VERSION]
		©2023 Electro-Voice
EXIT		

Table 12.1: Loudspeaker DSP control menu

12.4

INPUT list

INPUT DSP control menu

INPUTS 1 & 2		
LEVEL		0 dB (Default)
		MUTE, -80 dB - +42 dB
	EXIT	
	PHANTOM (INPUT 1 only)	OFF (Default)

	ON
PRESET	FLAT (Default)
	LOW CUT 80
	LOW CUT 120
	VOCAL MIC
	VOICE FILTER
	ND76 VOCAL
	RE520
	ND86 VOCAL
	ND96 VOCAL
	SPEECH
	ACOUST GUITAR
	ND66 A-GTR
	ELECTRIC GUITAR
	BASS GUITAR
	PERCUSSION
LINE INPUT	
COMP	OFF (Default)
	OFF, 1 - 100
TREBLE	0 dB (Default)
	-12 dB - +12 dB
MID	0 dB (Default)
	-12 dB - +12 dB
BASS	0 dB (Default)
	-12 dB - +12 dB
FX	0 dB (Default)
	-80 dB - +10 dB
PAN (stereo operation only)	C (Default)
	10 L - 10 R
DUCKER	OFF (Default)
	OFF, -1 - -40
EXIT	

Table 12.2: INPUTS 1 & 2 DSP control menu

INPUT BT			
LEVEL		0 dB (Default)	
		MUTE, -80 dB - +42 dB	
	EXIT		
	TREBLE	0 dB (Default)	
		-12 dB - +12 dB	
	MID	0 dB (Default)	
		-12 dB - +12 dB	
	BASS	0 dB (Default)	
		-12 dB - +12 dB	
	BAL (stereo operation only)	C (Default)	
		10 L - 10 R	
	BLUETOOTH	BACK	
		BLUETOOTH	ON (Default)
			OFF
		ID (4-digit unique device number)	
		CONTROL PAIR	
		AUDIO PAIR	
LINK SPEAKERS			
BACK			
EXIT			

Table 12.3: INPUT BT DSP control menu

12.5 Regulatory information

12.5.1 FCC information

IMPORTANT: Do not modify this unit! Changes or modifications not expressly approved by the manufacturer could void the user's authority, granted by the FCC, to operate the equipment.



Notice!

This equipment has been tested and found to comply with the limits for a Class B digital device, pursuant to Part 15 of the FCC Rules. These limits are designed to provide reasonable protection against harmful interference in a residential installation. This equipment generates, uses and can radiate radio frequency energy and, if not installed and used in accordance with the instructions, may cause harmful interference to radio communications. However, there is no guarantee interference will not occur in a particular installation.

If this equipment does cause harmful interference to radio or television reception or receive audible interference from radio, television or communications equipment, which can be determined by turning the equipment off and on. The user is encouraged to try to correct the interference by one or more of the following measures:

- Reorient or relocate the receiving antenna.
- Increase the separation between the equipment and receiver.
- Connect the equipment into an outlet on a circuit different from that to which the receiver is connected.
- Consult the dealer or an experienced radio/TV/communications equipment technician.

The device has been granted by FCC and IC, the FCC ID: ESV-ZLXG2 and IC: 1249A-ZLXG2.

Please take attention that changes or modification not expressly approved by the party responsible for compliance could void the user’s authority to operate the equipment.

This equipment should be installed and operated with a minimum distance of 20 cm between the radiator and your body.

This device complies with Part 15 of the FCC Rules and Industry Canada license-exempt RSS standard(s). Operation is subject to the following two conditions:

- (1) this device may not cause interference, and
- (2) this device must accept any interference, including interference that may cause undesired operation of the device.

Le présent appareil est conforme aux CNR d'Industrie Canada applicables aux appareils radioexempts de licence. L'exploitation est autorisée aux deux conditions suivantes :

- (1) l'appareil ne doit pas produire de brouillage, et
- (2) l'utilisateur de l'appareil doit accepter tout brouillage radioélectrique subi, même si le brouillage est susceptible d'en compromettre le fonctionnement.

This device contains licence-exempt transmitter(s)/receiver(s) that comply with Innovation, Science and Economic Development Canada’s licence-exempt RSS(s). Operation is subject to the following two conditions:

- (1) This device may not cause interference
- (2) This device must accept any interference, including interference that may cause undesired operation of the device.

Cet appareil contient des émetteurs / récepteurs exemptés de licence conformes aux RSS (RSS) d'Innovation, Sciences et Développement économique Canada. Le fonctionnement est soumis aux deux conditions suivantes: (1) Cet appareil ne doit pas causer d'interférences (2) Cet appareil doit accepter toutes les interférences, y compris celles susceptibles de provoquer un fonctionnement indésirable de l'appareil.

12.5.2 Simplified Declaration of Conformity (sDoC) for Europe (CE)

BG	С настоящото Bosch Security Systems, LLC декларира, че този тип радиосъоръжение ZLX-8P-G2-EU, ZLX-12P-G2-EU, ZLX-15P-G2-EU е в съответствие с Директива 2014/53/ЕС. Цялостният текст на ЕС декларацията за съответствие може да се намери на следния интернет адрес: www.electrovoice.com
CS	Tímto Bosch Security Systems, LLC prohlašuje, že typ rádiového zařízení ZLX-8P-G2-EU, ZLX-12P-G2-EU, ZLX-15P-G2-EU je v souladu se směrnici 2014/53/EU. Úplné znění EU prohlášení o shodě je k dispozici na této internetové adrese: www.electrovoice.com

DA	Hermed erklærer Bosch Security Systems, LLC , at radioudstyrstypen ZLX-8P-G2-EU, ZLX-12P-G2-EU, ZLX-15P-G2-EU er i overensstemmelse med direktiv 2014/53/EU. EU-overensstemmelseserklæringens fulde tekst kan findes på følgende internetadresse: www.electrovoice.com
DE	Hiermit erklärt Bosch Security Systems, LLC , dass der Funkanlagentyp ZLX-8P-G2-EU, ZLX-12P-G2-EU, ZLX-15P-G2-EU der Richtlinie 2014/53/EU entspricht. Der vollständige Text der EU-Konformitätserklärung ist unter der folgenden Internetadresse verfügbar: www.electrovoice.com
EL	Με την παρούσα ο/η Bosch Security Systems, LLC , δηλώνει ότι ο ραδιοεξοπλισμός ZLX-8P-G2-EU, ZLX-12P-G2-EU, ZLX-15P-G2-EU πληροί την οδηγία 2014/53/ΕΕ. Το πλήρες κείμενο της δήλωσης συμμόρφωσης ΕΕ διατίθεται στην ακόλουθη ιστοσελίδα στο διαδίκτυο: www.electrovoice.com
EN	Hereby, Bosch Security Systems, LLC declares that the radio equipment type ZLX-8P-G2-EU, ZLX-12P-G2-EU, ZLX-15P-G2-EU is in compliance with Directive 2014/53/EU and the relevant statutory requirements. The full text of the EU declaration of conformity and the UK declaration of conformity are available at the following internet address: www.electrovoice.com
ES	Por la presente, Bosch Security Systems, LLC declara que el tipo de equipo radioeléctrico ZLX-8P-G2-EU, ZLX-12P-G2-EU, ZLX-15P-G2-EU es conforme con la Directiva 2014/53/UE. El texto completo de la declaración UE de conformidad está disponible en la dirección Internet siguiente: www.electrovoice.com
ET	Käesolevaga deklareerib Bosch Security Systems, LLC , et käesolev raadioseadme tüüp ZLX-8P-G2-EU, ZLX-12P-G2-EU, ZLX-15P-G2-EU vastab direktiivi 2014/53/EL nõuetele. Eli vastavusdeklaratsiooni täielik tekst on kättesaadav järgmisel internetiaadressil: www.electrovoice.com
FI	Bosch Security Systems, LLC vakuuttaa, että radiolaitetyypit ZLX-8P-G2-EU, ZLX-12P-G2-EU, ZLX-15P-G2-EU on direktiivin 2014/53/EU mukainen. EU-vaatimustenmukaisuusvakuutuksen täysimittainen teksti on saatavilla seuraavassa internetosoitteessa: www.electrovoice.com
FR	Le soussigné, Bosch Security Systems, LLC , déclare que l'équipement radioélectrique du type ZLX-8P-G2-EU, ZLX-12P-G2-EU, ZLX-15P-G2-EU est conforme à la directive 2014/53/UE. Le texte complet de la déclaration UE de conformité est disponible à l'adresse internet suivante: www.electrovoice.com
HR	Bosch Security Systems, LLC ovime izjavljuje da je radijska oprema tipa ZLX-8P-G2-EU, ZLX-12P-G2-EU, ZLX-15P-G2-EU u skladu s Direktivom 2014/53/EU. Cjeloviti tekst EU izjave o sukladnosti dostupan je na sljedećoj internetskoj adresi: www.electrovoice.com
HU	Bosch Security Systems, LLC igazolja, hogy a ZLX-8P-G2-EU, ZLX-12P-G2-EU, ZLX-15P-G2-EU típusú rádióberendezés megfelel a 2014/53/EU irányelvnek. Az EU-megfelelőségi nyilatkozat teljes szövege elérhető a következő internetes címen: www.electrovoice.com
IT	Il fabbricante, Bosch Security Systems, LLC , dichiara che il tipo di apparecchiatura radio ZLX-8P-G2-EU, ZLX-12P-G2-EU, ZLX-15P-G2-EU è conforme alla direttiva 2014/53/UE. Il testo completo della dichiarazione di conformità UE è disponibile al seguente indirizzo Internet: www.electrovoice.com

LT	Aš, Bosch Security Systems, LLC , patvirtinu, kad radijo įrenginių tipas ZLX-8P-G2-EU, ZLX-12P-G2-EU, ZLX-15P-G2-EU atitinka Direktyvą 2014/53/ES. Visas ES atitikties deklaracijos tekstas prieinamas šiuo interneto adresu: www.electrovoice.com
LV	Ar šo Bosch Security Systems, LLC deklarē, ka radioiekārta ZLX-8P-G2-EU, ZLX-12P-G2-EU, ZLX-15P-G2-EU atbilst Direktīvai 2014/53/ES. Pilns ES atbilstības deklarācijas teksts ir pieejams šādā interneta vietnē: www.electrovoice.com
MT	B'dan, Bosch Security Systems, LLC , niddikjara li dan it-tip ta' tagħmir tar-radju ZLX-8P-G2-EU, ZLX-12P-G2-EU, ZLX-15P-G2-EU huwa konformi mad-Direttiva 2014/53/UE. It-test kollu tad-dikjarazzjoni ta' konformità tal-UE huwa disponibbli f'dan l-indirizz tal-Internet li ġej: www.electrovoice.com
NL	Hierbij verklaar ik, Bosch Security Systems, LLC , dat het type radioapparatuur ZLX-8P-G2-EU, ZLX-12P-G2-EU, ZLX-15P-G2-EU conform is met Richtlijn 2014/53/EU. De volledige tekst van de EU-conformiteitsverklaring kan worden geraadpleegd op het volgende internetadres: www.electrovoice.com
PL	Bosch Security Systems, LLC niniejszym oświadcza, że typ urządzenia radiowego ZLX-8P-G2-EU, ZLX-12P-G2-EU, ZLX-15P-G2-EU jest zgodny z dyrektywą 2014/53/UE. Pełny tekst deklaracji zgodności UE jest dostępny pod następującym adresem internetowym: www.electrovoice.com
PT	O(a) abaixo assinado(a) Bosch Security Systems, LLC declara que o presente tipo de equipamento de rádio ZLX-8P-G2-EU, ZLX-12P-G2-EU, ZLX-15P-G2-EU está em conformidade com a Diretiva 2014/53/UE. O texto integral da declaração de conformidade está disponível no seguinte endereço de Internet: www.electrovoice.com
RO	Prin prezenta, Bosch Security Systems, LLC declară că tipul de echipamente radio ZLX-8P-G2-EU, ZLX-12P-G2-EU, ZLX-15P-G2-EU este în conformitate cu Directiva 2014/53/UE. Textul integral al declarației UE de conformitate este disponibil la următoarea adresă internet: www.electrovoice.com
SK	Bosch Security Systems, LLC týmto vyhlasuje, že rádiové zariadenie typu ZLX-8P-G2-EU, ZLX-12P-G2-EU, ZLX-15P-G2-EU je v súlade so smernicou 2014/53/EÚ. Úplné EÚ vyhlásenie o zhode je k dispozícii na tejto internetovej adrese: www.electrovoice.com
SL	Bosch Security Systems, LLC potrjuje, da je tip radijske opreme ZLX-8P-G2-EU, ZLX-12P-G2-EU, ZLX-15P-G2-EU skladen z Direktivo 2014/53/EU. Celotno besedilo izjave EU o skladnosti je na voljo na naslednjem spletnem naslovu: www.electrovoice.com
SV	Härmed försäkrar Bosch Security Systems, LLC att denna typ av radioutrustning ZLX-8P-G2-EU, ZLX-12P-G2-EU, ZLX-15P-G2-EU överensstämmer med direktiv 2014/53/EU. Den fullständiga texten till EU-försäkran om överensstämmelse finns på följande webbadress: www.electrovoice.com

12.5.3

Regulatory notice for CE/UKCA - Information concerning the use of apparatus

This equipment has been tested and found to be compliant with class B emission limits. The electromagnetic disturbance generated does not exceed the level above which radio and telecommunications equipment or other equipment cannot operate as intended. This means that there are no restrictions for usage in residential and commercial environments.

12.5.4

Certifications

Brazil:

Após uma perturbação da rede elétrica, o ZLX-G2 pode entrar em estado de segurança. Neste caso, você deve desligar e ligar o dispositivo novamente.

Este equipamento não tem direito à proteção contra interferência prejudicial e não pode causar interferência em sistemas devidamente autorizados.

Incorpora produto homologado pela ANATEL sob número 01000-24-07826.

Para mais informações, consulte o site da ANATEL: www.anatel.gov.br.

Cambodia:

ZLX-8P-G2-EU TRC identifier: RC-TA-2023-1134

ZLX-12P-G2-EU TRC identifier: RC-TA-2023-1135

ZLX-15P-G2-EU TRC identifier: RC-TA-2023-1136

Malaysia:



Mexico:

“La operación de este equipo está sujeta a las siguientes dos condiciones: (1) es posible que este equipo o dispositivo no cause interferencia perjudicial y (2) este equipo o dispositivo debe aceptar cualquier interferencia, incluyendo la que pueda causar su operación no deseada”



IFETEL ID: ROELZL24-25784

Morocco:

ZLX-8P-G2

AGREE PAR L'ANRT MAROC

Numéro d'agrément: MR00003974ANRT2024
Date d'agrément: 12/09/2024

ZLX-12P-G2

AGREE PAR L'ANRT MAROC

Numéro d'agrément: MR00003975ANRT2024
Date d'agrément: 12/09/2024

ZLX-15P-G2

AGREE PAR L'ANRT MAROC

Numéro d'agrément: MR00004004ANRT2024
Date d'agrément: 13/09/2024

Pakistan:

ZLX-15P-G2-EU



ZLX-12P-G2-EU



ZLX-8P-G2-EU

**Republic of Korea:**

R-R-B6S-ZLX-G2

기자재명칭: Bluetooth speaker

모델명: ZLX-8P-G2-EU, ZLX-12P-G2-EU, ZLX-15P-G2-EU

정격: AC 100-240V ~, 50 - 60Hz, 0.8 - 0.5A

수입업체(상호)명: 로버트보쉬코리아(유)

제조사: Bosch Security Systems, LLC.

제조연월: 별도표기

<http://www.apache.org/licenses/>

TERMS AND CONDITIONS FOR USE, REPRODUCTION, AND DISTRIBUTION

1. Definitions.

"License" shall mean the terms and conditions for use, reproduction, and distribution as defined by Sections 1 through 9 of this document.

"Licensor" shall mean the copyright owner or entity authorized by the copyright owner that is granting the License.

"Legal Entity" shall mean the union of the acting entity and all other entities that control, are controlled by, or are under common control with that entity. For the purposes of this definition, "control" means (i) the power, direct or indirect, to cause the direction or management of such entity, whether by contract or otherwise, or (ii) ownership of fifty percent (50%) or more of the outstanding shares, or (iii) beneficial ownership of such entity.

"You" (or "Your") shall mean an individual or Legal Entity exercising permissions granted by this License.

"Source" form shall mean the preferred form for making modifications, including but not limited to software source code, documentation source, and configuration files.

"Object" form shall mean any form resulting from mechanical transformation or translation of a Source form, including but not limited to compiled object code, generated documentation, and conversions to other media types.

"Work" shall mean the work of authorship, whether in Source or Object form, made available under the License, as indicated by a copyright notice that is included in or attached to the work (an example is provided in the Appendix below).

"Derivative Works" shall mean any work, whether in Source or Object form, that is based on (or derived from) the Work and for which the editorial revisions, annotations, elaborations, or other modifications represent, as a whole, an original work of authorship. For the purposes of this License, Derivative Works shall not include works that remain separable from, or merely link (or bind by name) to the interfaces of, the Work and Derivative Works thereof.

"Contribution" shall mean any work of authorship, including the original version of the Work and any modifications or additions to that Work or Derivative Works thereof, that is intentionally submitted to Licensor for inclusion in the Work by the copyright owner or by an individual or Legal Entity authorized to submit on behalf of the copyright owner. For the purposes of this definition, "submitted" means any form of electronic, verbal, or written communication sent to the Licensor or its representatives, including but not limited to communication on electronic mailing lists, source code control systems, and issue tracking systems that are managed by, or on behalf of, the Licensor for the purpose of discussing and improving the Work, but excluding communication that is conspicuously marked or otherwise designated in writing by the copyright owner as "Not a Contribution."

"Contributor" shall mean Licensor and any individual or Legal Entity on behalf of whom a Contribution has been received by Licensor and subsequently incorporated within the Work.

2. Grant of Copyright License.

Subject to the terms and conditions of this License, each Contributor hereby grants to You a perpetual, worldwide, non-exclusive, no-charge, royalty-free, irrevocable copyright license to reproduce, prepare Derivative Works of, publicly display, publicly perform, sublicense, and distribute the Work and such Derivative Works in Source or Object form.

3. Grant of Patent License.

Subject to the terms and conditions of this License, each Contributor hereby grants to You a perpetual, worldwide, non-exclusive, no-charge, royalty-free, irrevocable (except as stated in this section) patent license to make, have made, use, offer to sell, sell, import, and otherwise transfer the Work, where such license applies only to those patent claims licensable by such Contributor that are necessarily infringed by their Contribution(s) alone or by combination of their Contribution(s) with the Work to which such Contribution(s) was submitted. If You institute patent litigation against any entity (including a cross-claim or counterclaim in a lawsuit) alleging that the Work or a Contribution incorporated within the Work constitutes direct or contributory patent infringement, then any patent licenses granted to You under this License for that Work shall terminate as of the date such litigation is filed.

4. Redistribution.

You may reproduce and distribute copies of the Work or Derivative Works thereof in any medium, with or without modifications, and in Source or Object form, provided that You meet the following conditions:

- (a) You must give any other recipients of the Work or Derivative Works a copy of this License; and
- (b) You must cause any modified files to carry prominent notices stating that You changed the files; and
- (c) You must retain, in the Source form of any Derivative Works that You distribute, all copyright, patent, trademark, and attribution notices from the Source form of the Work, excluding those notices that do not pertain to any part of the Derivative Works; and
- (d) If the Work includes a "NOTICE" text file as part of its distribution, then any Derivative Works that You distribute must include a readable copy of the attribution notices contained within such NOTICE file, excluding those notices that do not pertain to any part of the Derivative Works, in at least one of the following places: within a NOTICE text file distributed as part of the Derivative Works; within the Source form or documentation, if provided along with the Derivative Works; or, within a display generated by the Derivative Works, if and wherever such third-party notices normally appear. The contents of the NOTICE file are for informational purposes only and do not modify the License. You may add Your own attribution notices within Derivative Works that You distribute, alongside or as an addendum to the NOTICE text from the Work, provided that such additional attribution notices cannot be construed as modifying the License.

You may add Your own copyright statement to Your modifications and may provide additional or different license terms and conditions for use, reproduction, or distribution of Your modifications, or for any such Derivative Works as a whole, provided Your use, reproduction, and distribution of the Work otherwise complies with the conditions stated in this License.

5. Submission of Contributions.

Unless You explicitly state otherwise, any Contribution intentionally submitted for inclusion in the Work by You to the Licensor shall be under the terms and conditions of this License, without any additional terms or conditions. Notwithstanding the above, nothing herein shall supersede or modify the terms of any separate license agreement you may have executed with Licensor regarding such Contributions.

6. Trademarks.

This License does not grant permission to use the trade names, trademarks, service marks, or product names of the Licensor, except as required for reasonable and customary use in describing the origin of the Work and reproducing the content of the NOTICE file.

7. Disclaimer of Warranty.

Unless required by applicable law or agreed to in writing, Licensor provides the Work (and each Contributor provides its Contributions) on an "AS IS" BASIS, WITHOUT WARRANTIES OR CONDITIONS OF ANY KIND, either express or implied, including, without limitation, any warranties or conditions of TITLE, NON-INFRINGEMENT, MERCHANTABILITY, or FITNESS FOR A PARTICULAR PURPOSE. You are solely responsible for determining the appropriateness of using or redistributing the Work and assume any risks associated with Your exercise of permissions under this License.

8. Limitation of Liability.

In no event and under no legal theory, whether in tort (including negligence), contract, or otherwise, unless required by applicable law (such as deliberate and grossly negligent acts) or agreed to in writing, shall any Contributor be liable to You for damages, including any direct, indirect, special, incidental, or consequential damages of any character arising as a result of this License or out of the use or inability to use the Work (including but not limited to damages for loss of goodwill, work stoppage, computer failure or malfunction, or any and all other commercial damages or losses), even if such Contributor has been advised of the possibility of such damages.

9. Accepting Warranty or Additional Liability.

While redistributing the Work or Derivative Works thereof, You may choose to offer, and charge a fee for, acceptance of support, warranty, indemnity, or other liability obligations and/or rights consistent with this License. However, in accepting such obligations, You may act only on Your own behalf and on Your sole responsibility, not on behalf of any other Contributor, and only if You agree to indemnify, defend, and hold each Contributor harmless for any liability incurred by, or claims asserted against, such Contributor by reason of your accepting any such warranty or additional liability.

END OF TERMS AND CONDITIONS

APPENDIX: How to apply the Apache License to your work.

To apply the Apache License to your work, attach the following boilerplate notice, with the fields enclosed by brackets "[]" replaced with your own identifying information. (Don't include the brackets!) The text should be enclosed in the appropriate comment syntax for the file format. We also recommend that a file or class name and description of purpose be included on the same "printed page" as the copyright notice for easier identification within third-party archives.

Copyright [yyyy] [name of copyright owner]

Licensed under the Apache License, Version 2.0 (the "License"); you may not use this file except in compliance with the License. You may obtain a copy of the License at <http://www.apache.org/licenses/LICENSE-2.0>

Unless required by applicable law or agreed to in writing, software distributed under the License is distributed on an "AS IS" BASIS, WITHOUT WARRANTIES OR CONDITIONS OF ANY KIND, either express or implied. See the License for the specific language governing permissions and limitations under the License.

STM32F4 HAL

Redistribution and use in source and binary forms, with or without modification, are permitted provided that the following conditions are met:

1. Redistributions of source code must retain the above copyright notice, this list of conditions and the following disclaimer.
2. Redistributions in binary form must reproduce the above copyright notice, this list of conditions and the following disclaimer in the documentation and/or other materials provided with the distribution.
3. Neither the name of the copyright holder nor the names of its contributors may be used to endorse or promote products derived from this software without specific prior written permission.

THIS SOFTWARE IS PROVIDED BY THE COPYRIGHT HOLDERS AND CONTRIBUTORS "AS IS" AND ANY EXPRESS OR IMPLIED WARRANTIES, INCLUDING, BUT NOT LIMITED TO, THE IMPLIED WARRANTIES OF MERCHANTABILITY AND FITNESS FOR A PARTICULAR PURPOSE ARE DISCLAIMED. IN NO EVENT SHALL THE COPYRIGHT HOLDER OR CONTRIBUTORS BE LIABLE FOR ANY DIRECT, INDIRECT, INCIDENTAL, SPECIAL, EXEMPLARY, OR CONSEQUENTIAL DAMAGES (INCLUDING, BUT NOT LIMITED TO, PROCUREMENT OF SUBSTITUTE GOODS OR SERVICES; LOSS OF USE, DATA, OR PROFITS; OR BUSINESS INTERRUPTION) HOWEVER CAUSED AND ON ANY THEORY OF LIABILITY, WHETHER IN CONTRACT, STRICT LIABILITY, OR TORT (INCLUDING NEGLIGENCE OR OTHERWISE) ARISING IN ANY WAY OUT OF THE USE OF THIS SOFTWARE, EVEN IF ADVISED OF THE POSSIBILITY OF SUCH DAMAGE.

QTIL Firmware

This Notice txt file contains certain notices Qualcomm Technologies International, Ltd. ("QTIL") is required to provide with certain software components. Except where prohibited by the open source license, the content of this file is provided solely to satisfy QTIL's attribution and notice requirement and your use of such software components together with the QTIL software ("Software") is subject to the terms of your separate license from QTIL. Compliance with all copyright laws and software licenses included in this file are the responsibility of the user. Except as may be granted by separate express written agreement, this file provides no license to any patents, trademarks, copyrights, or other intellectual property of Qualcomm Incorporated or any of its subsidiaries.

Software provided with this notice is NOT A CONTRIBUTION to any open source project. If alternative licensing is available for any of the components with licenses or attributions provided below, a license choice is made for receiving such code by QTIL.

Copyright (c) 2017 Qualcomm Technologies International, Ltd. All rights reserved. Qualcomm is a trademark of Qualcomm Incorporated, registered in the United States and other countries. All Qualcomm Incorporated Trademarks are used with permission. Other products and brand names may be trademarks or registered trademarks of their respective owners.

*

* Copyright (c) 1998 Todd C. Miller <Todd.Miller@courtesan.com>

*

* Permission to use, copy, modify, and distribute this software for any
 * purpose with or without fee is hereby granted, provided that the above
 * copyright notice and this permission notice appear in all copies.

*

* THE SOFTWARE IS PROVIDED "AS IS" AND THE AUTHOR DISCLAIMS ALL WARRANTIES

* WITH REGARD TO THIS SOFTWARE INCLUDING ALL IMPLIED WARRANTIES OF
* MERCHANTABILITY AND FITNESS. IN NO EVENT SHALL THE AUTHOR BE LIABLE FOR
* ANY SPECIAL, DIRECT, INDIRECT, OR CONSEQUENTIAL DAMAGES OR ANY DAMAGES
* WHATSOEVER RESULTING FROM LOSS OF USE, DATA OR PROFITS, WHETHER IN AN
* ACTION OF CONTRACT, NEGLIGENCE OR OTHER TORTIOUS ACTION, ARISING OUT OF
* OR IN CONNECTION WITH THE USE OR PERFORMANCE OF THIS SOFTWARE.

*/

* Copyright (c) 1990 The Regents of the University of California.

* All rights reserved.

*

* Redistribution and use in source and binary forms, with or without
* modification, are permitted provided that the following conditions
* are met:

* 1. Redistributions of source code must retain the above copyright
* notice, this list of conditions and the following disclaimer.

* 2. Redistributions in binary form must reproduce the above copyright
* notice, this list of conditions and the following disclaimer in the
* documentation and/or other materials provided with the distribution.

* 3. Neither the name of the University nor the names of its contributors
* may be used to endorse or promote products derived from this software
* without specific prior written permission.

*

* THIS SOFTWARE IS PROVIDED BY THE REGENTS AND CONTRIBUTORS ``AS IS'' AND
* ANY EXPRESS OR IMPLIED WARRANTIES, INCLUDING, BUT NOT LIMITED TO, THE
* IMPLIED WARRANTIES OF MERCHANTABILITY AND FITNESS FOR A PARTICULAR PURPOSE
* ARE DISCLAIMED. IN NO EVENT SHALL THE REGENTS OR CONTRIBUTORS BE LIABLE
* FOR ANY DIRECT, INDIRECT, INCIDENTAL, SPECIAL, EXEMPLARY, OR CONSEQUENTIAL
* DAMAGES (INCLUDING, BUT NOT LIMITED TO, PROCUREMENT OF SUBSTITUTE GOODS
* OR SERVICES; LOSS OF USE, DATA, OR PROFITS; OR BUSINESS INTERRUPTION)
* HOWEVER CAUSED AND ON ANY THEORY OF LIABILITY, WHETHER IN CONTRACT, STRICT
* LIABILITY, OR TORT (INCLUDING NEGLIGENCE OR OTHERWISE) ARISING IN ANY WAY
* OUT OF THE USE OF THIS SOFTWARE, EVEN IF ADVISED OF THE POSSIBILITY OF
* SUCH DAMAGE.

QTIL Audio

This Notice txt file contains certain notices Qualcomm Technologies International, Ltd. ("QTIL") is required to provide with certain software components. Except where prohibited by the open source license, the content of this file is provided solely to satisfy QTIL's attribution and notice requirement and your use of such software components together with the QTIL software ("Software") is subject to the terms of your separate license from QTIL. Compliance with all copyright laws and software licenses included in this file are the responsibility of the user. Except as may be granted by separate express written agreement, this file provides no license to any patents, trademarks, copyrights, or other intellectual property of Qualcomm Incorporated or any of its subsidiaries.

Software provided with this notice is NOT A CONTRIBUTION to any open source project. If alternative licensing is available for any of the components with licenses or attributions provided below, a license choice is made for receiving such code by QTIL.

Copyright (c) 2018 Qualcomm Technologies International, Ltd. All rights reserved. Qualcomm is a trademark of Qualcomm Incorporated, registered in the United States and other countries. All Qualcomm Incorporated Trademarks are used with permission. Other products and brand names may be trademarks or registered trademarks of their respective owners.

/* Copyright (c) 2007-2008 CSIRO
Copyright (c) 2007-2009 Xiph.Org Foundation
Copyright (c) 2008 Gregory Maxwell
Written by Jean-Marc Valin and Gregory Maxwell */

/*

Redistribution and use in source and binary forms, with or without modification, are permitted provided that the following conditions are met:

Redistributions of source code must retain the above copyright notice, this list of conditions and the following disclaimer.

Redistributions in binary form must reproduce the above copyright notice, this list of conditions and the following disclaimer in the documentation and/or other materials provided with the distribution.

Neither the name of the Xiph.org Foundation nor the names of its contributors may be used to endorse or promote products derived from this software without specific prior written permission.

THIS SOFTWARE IS PROVIDED BY THE COPYRIGHT HOLDERS AND CONTRIBUTORS "AS IS" AND ANY EXPRESS OR IMPLIED WARRANTIES, INCLUDING, BUT NOT LIMITED TO, THE IMPLIED WARRANTIES OF MERCHANTABILITY AND FITNESS FOR A PARTICULAR PURPOSE ARE DISCLAIMED. IN NO EVENT SHALL THE FOUNDATION OR CONTRIBUTORS BE LIABLE FOR ANY DIRECT, INDIRECT, INCIDENTAL, SPECIAL, EXEMPLARY, OR CONSEQUENTIAL DAMAGES (INCLUDING, BUT NOT LIMITED TO, PROCUREMENT OF SUBSTITUTE GOODS OR SERVICES; LOSS OF USE, DATA, OR PROFITS; OR BUSINESS INTERRUPTION) HOWEVER CAUSED AND ON ANY THEORY OF LIABILITY, WHETHER IN CONTRACT, STRICT LIABILITY, OR TORT (INCLUDING NEGLIGENCE OR OTHERWISE) ARISING IN ANY WAY OUT OF THE USE OF THIS SOFTWARE, EVEN IF ADVISED OF THE POSSIBILITY OF SUCH DAMAGE.

*/

Copyright (c) 2003-2004, Mark Borgerding

All rights reserved.

Redistribution and use in source and binary forms, with or without modification, are permitted provided that the following conditions are met:

* Redistributions of source code must retain the above copyright notice, this list of conditions and the following disclaimer.

* Redistributions in binary form must reproduce the above copyright notice, this list of conditions and the following disclaimer in the documentation and/or other materials provided with the distribution.

THIS SOFTWARE IS PROVIDED BY THE COPYRIGHT HOLDERS AND CONTRIBUTORS "AS IS" AND ANY EXPRESS OR IMPLIED WARRANTIES, INCLUDING, BUT NOT LIMITED TO, THE IMPLIED WARRANTIES OF MERCHANTABILITY AND FITNESS FOR A PARTICULAR PURPOSE ARE

DISCLAIMED. IN NO EVENT SHALL THE COPYRIGHT OWNER OR CONTRIBUTORS BE LIABLE FOR ANY DIRECT, INDIRECT, INCIDENTAL, SPECIAL, EXEMPLARY, OR CONSEQUENTIAL DAMAGES (INCLUDING, BUT NOT LIMITED TO, PROCUREMENT OF SUBSTITUTE GOODS OR SERVICES; LOSS OF USE, DATA, OR PROFITS; OR BUSINESS INTERRUPTION) HOWEVER CAUSED AND ON ANY THEORY OF LIABILITY, WHETHER IN CONTRACT, STRICT LIABILITY, OR TORT (INCLUDING NEGLIGENCE OR OTHERWISE) ARISING IN ANY WAY OUT OF THE USE OF THIS SOFTWARE, EVEN IF ADVISED OF THE POSSIBILITY OF SUCH DAMAGE.

Copyright (c) 2003-2008 Jean-Marc Valin
Copyright (c) 2007-2008 CSIRO
Copyright (c) 2007-2009 Xiph.Org Foundation
Written by Jean-Marc Valin

Redistribution and use in source and binary forms, with or without modification, are permitted provided that the following conditions are met:

- Redistributions of source code must retain the above copyright notice, this list of conditions and the following disclaimer.
- Redistributions in binary form must reproduce the above copyright notice, this list of conditions and the following disclaimer in the documentation and/or other materials provided with the distribution.

THIS SOFTWARE IS PROVIDED BY THE COPYRIGHT HOLDERS AND CONTRIBUTORS ``AS IS'' AND ANY EXPRESS OR IMPLIED WARRANTIES, INCLUDING, BUT NOT LIMITED TO, THE IMPLIED WARRANTIES OF MERCHANTABILITY AND FITNESS FOR A PARTICULAR PURPOSE ARE DISCLAIMED. IN NO EVENT SHALL THE COPYRIGHT OWNER OR CONTRIBUTORS BE LIABLE FOR ANY DIRECT, INDIRECT, INCIDENTAL, SPECIAL, EXEMPLARY, OR CONSEQUENTIAL DAMAGES (INCLUDING, BUT NOT LIMITED TO, PROCUREMENT OF SUBSTITUTE GOODS OR SERVICES; LOSS OF USE, DATA, OR PROFITS; OR BUSINESS INTERRUPTION) HOWEVER CAUSED AND ON ANY THEORY OF LIABILITY, WHETHER IN CONTRACT, STRICT LIABILITY, OR TORT (INCLUDING NEGLIGENCE OR OTHERWISE) ARISING IN ANY WAY OUT OF THE USE OF THIS SOFTWARE, EVEN IF ADVISED OF THE POSSIBILITY OF SUCH DAMAGE.

Copyright (c) 2007-2008 CSIRO
Copyright (c) 2007-2009 Xiph.Org Foundation
Copyright (c) 2008-2009 Gregory Maxwell
Written by Jean-Marc Valin and Gregory Maxwell

Redistribution and use in source and binary forms, with or without modification, are permitted provided that the following conditions are met:

- Redistributions of source code must retain the above copyright notice, this list of conditions and the following disclaimer.
- Redistributions in binary form must reproduce the above copyright notice, this list of conditions and the following disclaimer in the documentation and/or other materials provided with the distribution.

THIS SOFTWARE IS PROVIDED BY THE COPYRIGHT HOLDERS AND CONTRIBUTORS ``AS IS'' AND ANY EXPRESS OR IMPLIED WARRANTIES, INCLUDING, BUT NOT LIMITED TO, THE IMPLIED WARRANTIES OF MERCHANTABILITY AND FITNESS FOR A PARTICULAR PURPOSE ARE DISCLAIMED. IN NO EVENT SHALL THE COPYRIGHT OWNER OR CONTRIBUTORS BE LIABLE FOR

ANY DIRECT, INDIRECT, INCIDENTAL, SPECIAL, EXEMPLARY, OR CONSEQUENTIAL DAMAGES (INCLUDING, BUT NOT LIMITED TO, PROCUREMENT OF SUBSTITUTE GOODS OR SERVICES; LOSS OF USE, DATA, OR PROFITS; OR BUSINESS INTERRUPTION) HOWEVER CAUSED AND ON ANY THEORY OF LIABILITY, WHETHER IN CONTRACT, STRICT LIABILITY, OR TORT (INCLUDING NEGLIGENCE OR OTHERWISE) ARISING IN ANY WAY OUT OF THE USE OF THIS SOFTWARE, EVEN IF ADVISED OF THE POSSIBILITY OF SUCH DAMAGE.

Copyright (c) 2007-2008 CSIRO
Copyright (c) 2007-2010 Xiph.Org Foundation
Copyright (c) 2008 Gregory Maxwell
Written by Jean-Marc Valin and Gregory Maxwell

Redistribution and use in source and binary forms, with or without modification, are permitted provided that the following conditions are met:

- Redistributions of source code must retain the above copyright notice, this list of conditions and the following disclaimer.
- Redistributions in binary form must reproduce the above copyright notice, this list of conditions and the following disclaimer in the documentation and/or other materials provided with the distribution.

THIS SOFTWARE IS PROVIDED BY THE COPYRIGHT HOLDERS AND CONTRIBUTORS "AS IS" AND ANY EXPRESS OR IMPLIED WARRANTIES, INCLUDING, BUT NOT LIMITED TO, THE IMPLIED WARRANTIES OF MERCHANTABILITY AND FITNESS FOR A PARTICULAR PURPOSE ARE DISCLAIMED. IN NO EVENT SHALL THE COPYRIGHT OWNER OR CONTRIBUTORS BE LIABLE FOR ANY DIRECT, INDIRECT, INCIDENTAL, SPECIAL, EXEMPLARY, OR CONSEQUENTIAL DAMAGES (INCLUDING, BUT NOT LIMITED TO, PROCUREMENT OF SUBSTITUTE GOODS OR SERVICES; LOSS OF USE, DATA, OR PROFITS; OR BUSINESS INTERRUPTION) HOWEVER CAUSED AND ON ANY THEORY OF LIABILITY, WHETHER IN CONTRACT, STRICT LIABILITY, OR TORT (INCLUDING NEGLIGENCE OR OTHERWISE) ARISING IN ANY WAY OUT OF THE USE OF THIS SOFTWARE, EVEN IF ADVISED OF THE POSSIBILITY OF SUCH DAMAGE.

Copyright (c) 2011, Skype Limited. All rights reserved.

Redistribution and use in source and binary forms, with or without modification, are permitted provided that the following conditions are met:

- Redistributions of source code must retain the above copyright notice, this list of conditions and the following disclaimer.
- Redistributions in binary form must reproduce the above copyright notice, this list of conditions and the following disclaimer in the documentation and/or other materials provided with the distribution.
- Neither the name of Internet Society, IETF or IETF Trust, nor the names of specific contributors, may be used to endorse or promote products derived from this software without specific prior written permission.

THIS SOFTWARE IS PROVIDED BY THE COPYRIGHT HOLDERS AND CONTRIBUTORS "AS IS" AND ANY EXPRESS OR IMPLIED WARRANTIES, INCLUDING, BUT NOT LIMITED TO, THE IMPLIED WARRANTIES OF MERCHANTABILITY AND FITNESS FOR A PARTICULAR PURPOSE ARE DISCLAIMED. IN NO EVENT SHALL THE COPYRIGHT OWNER OR CONTRIBUTORS BE LIABLE FOR ANY DIRECT, INDIRECT, INCIDENTAL, SPECIAL, EXEMPLARY, OR CONSEQUENTIAL DAMAGES (INCLUDING, BUT NOT LIMITED TO, PROCUREMENT OF SUBSTITUTE GOODS OR SERVICES; LOSS OF USE, DATA, OR PROFITS; OR BUSINESS INTERRUPTION) HOWEVER CAUSED AND ON

ANY THEORY OF LIABILITY, WHETHER IN CONTRACT, STRICT LIABILITY, OR TORT (INCLUDING NEGLIGENCE OR OTHERWISE) ARISING IN ANY WAY OUT OF THE USE OF THIS SOFTWARE, EVEN IF ADVISED OF THE POSSIBILITY OF SUCH DAMAGE.

Copyright (c) 2007-2008 CSIRO

Copyright (c) 2007-2009 Xiph.Org Foundation

Copyright (c) 2007-2009 Timothy B. Terriberry

Written by Timothy B. Terriberry and Jean-Marc Valin

Redistribution and use in source and binary forms, with or without modification, are permitted provided that the following conditions are met:

- Redistributions of source code must retain the above copyright notice, this list of conditions and the following disclaimer.
- Redistributions in binary form must reproduce the above copyright notice, this list of conditions and the following disclaimer in the documentation and/or other materials provided with the distribution.

THIS SOFTWARE IS PROVIDED BY THE COPYRIGHT HOLDERS AND CONTRIBUTORS "AS IS" AND ANY EXPRESS OR IMPLIED WARRANTIES, INCLUDING, BUT NOT LIMITED TO, THE IMPLIED WARRANTIES OF MERCHANTABILITY AND FITNESS FOR A PARTICULAR PURPOSE ARE DISCLAIMED. IN NO EVENT SHALL THE COPYRIGHT OWNER OR CONTRIBUTORS BE LIABLE FOR ANY DIRECT, INDIRECT, INCIDENTAL, SPECIAL, EXEMPLARY, OR CONSEQUENTIAL DAMAGES (INCLUDING, BUT NOT LIMITED TO, PROCUREMENT OF SUBSTITUTE GOODS OR SERVICES; LOSS OF USE, DATA, OR PROFITS; OR BUSINESS INTERRUPTION) HOWEVER CAUSED AND ON ANY THEORY OF LIABILITY, WHETHER IN CONTRACT, STRICT LIABILITY, OR TORT (INCLUDING NEGLIGENCE OR OTHERWISE) ARISING IN ANY WAY OUT OF THE USE OF THIS SOFTWARE, EVEN IF ADVISED OF THE POSSIBILITY OF SUCH DAMAGE.

Copyright (c) 2003-2008 Timothy B. Terriberry

Copyright (c) 2008 Xiph.Org Foundation

Redistribution and use in source and binary forms, with or without modification, are permitted provided that the following conditions are met:

- Redistributions of source code must retain the above copyright notice, this list of conditions and the following disclaimer.
- Redistributions in binary form must reproduce the above copyright notice, this list of conditions and the following disclaimer in the documentation and/or other materials provided with the distribution.

THIS SOFTWARE IS PROVIDED BY THE COPYRIGHT HOLDERS AND CONTRIBUTORS "AS IS" AND ANY EXPRESS OR IMPLIED WARRANTIES, INCLUDING, BUT NOT LIMITED TO, THE IMPLIED WARRANTIES OF MERCHANTABILITY AND FITNESS FOR A PARTICULAR PURPOSE ARE DISCLAIMED. IN NO EVENT SHALL THE COPYRIGHT OWNER OR CONTRIBUTORS BE LIABLE FOR ANY DIRECT, INDIRECT, INCIDENTAL, SPECIAL, EXEMPLARY, OR CONSEQUENTIAL DAMAGES (INCLUDING, BUT NOT LIMITED TO, PROCUREMENT OF SUBSTITUTE GOODS OR SERVICES; LOSS OF USE, DATA, OR PROFITS; OR BUSINESS INTERRUPTION) HOWEVER CAUSED AND ON ANY THEORY OF LIABILITY, WHETHER IN CONTRACT, STRICT LIABILITY, OR TORT (INCLUDING NEGLIGENCE OR OTHERWISE) ARISING IN ANY WAY OUT OF THE USE OF THIS SOFTWARE, EVEN IF ADVISED OF THE POSSIBILITY OF SUCH DAMAGE.

Copyright (c) 2001-2011 Timothy B. Terriberry

Redistribution and use in source and binary forms, with or without modification, are permitted provided that the following conditions are met:

- Redistributions of source code must retain the above copyright notice, this list of conditions and the following disclaimer.
- Redistributions in binary form must reproduce the above copyright notice, this list of conditions and the following disclaimer in the documentation and/or other materials provided with the distribution.

THIS SOFTWARE IS PROVIDED BY THE COPYRIGHT HOLDERS AND CONTRIBUTORS "AS IS" AND ANY EXPRESS OR IMPLIED WARRANTIES, INCLUDING, BUT NOT LIMITED TO, THE IMPLIED WARRANTIES OF MERCHANTABILITY AND FITNESS FOR A PARTICULAR PURPOSE ARE DISCLAIMED. IN NO EVENT SHALL THE COPYRIGHT OWNER OR CONTRIBUTORS BE LIABLE FOR ANY DIRECT, INDIRECT, INCIDENTAL, SPECIAL, EXEMPLARY, OR CONSEQUENTIAL DAMAGES (INCLUDING, BUT NOT LIMITED TO, PROCUREMENT OF SUBSTITUTE GOODS OR SERVICES; LOSS OF USE, DATA, OR PROFITS; OR BUSINESS INTERRUPTION) HOWEVER CAUSED AND ON ANY THEORY OF LIABILITY, WHETHER IN CONTRACT, STRICT LIABILITY, OR TORT (INCLUDING NEGLIGENCE OR OTHERWISE) ARISING IN ANY WAY OUT OF THE USE OF THIS SOFTWARE, EVEN IF ADVISED OF THE POSSIBILITY OF SUCH DAMAGE.

Copyright (c) 2001-2011 Timothy B. Terriberry

Copyright (c) 2008-2009 Xiph.Org Foundation

Redistribution and use in source and binary forms, with or without modification, are permitted provided that the following conditions are met:

- Redistributions of source code must retain the above copyright notice, this list of conditions and the following disclaimer.
- Redistributions in binary form must reproduce the above copyright notice, this list of conditions and the following disclaimer in the documentation and/or other materials provided with the distribution.

THIS SOFTWARE IS PROVIDED BY THE COPYRIGHT HOLDERS AND CONTRIBUTORS "AS IS" AND ANY EXPRESS OR IMPLIED WARRANTIES, INCLUDING, BUT NOT LIMITED TO, THE IMPLIED WARRANTIES OF MERCHANTABILITY AND FITNESS FOR A PARTICULAR PURPOSE ARE DISCLAIMED. IN NO EVENT SHALL THE COPYRIGHT OWNER OR CONTRIBUTORS BE LIABLE FOR ANY DIRECT, INDIRECT, INCIDENTAL, SPECIAL, EXEMPLARY, OR CONSEQUENTIAL DAMAGES (INCLUDING, BUT NOT LIMITED TO, PROCUREMENT OF SUBSTITUTE GOODS OR SERVICES; LOSS OF USE, DATA, OR PROFITS; OR BUSINESS INTERRUPTION) HOWEVER CAUSED AND ON ANY THEORY OF LIABILITY, WHETHER IN CONTRACT, STRICT LIABILITY, OR TORT (INCLUDING NEGLIGENCE OR OTHERWISE) ARISING IN ANY WAY OUT OF THE USE OF THIS SOFTWARE, EVEN IF ADVISED OF THE POSSIBILITY OF SUCH DAMAGE.

Copyright (C) 2007-2009 Xiph.Org Foundation

Copyright (C) 2003-2008 Jean-Marc Valin

Copyright (C) 2007-2008 CSIRO

Redistribution and use in source and binary forms, with or without modification, are permitted provided that the following conditions are met:

- Redistributions of source code must retain the above copyright notice, this list of conditions and the following disclaimer.
- Redistributions in binary form must reproduce the above copyright notice, this list of conditions and the following disclaimer in the documentation and/or other materials provided with the distribution.

THIS SOFTWARE IS PROVIDED BY THE COPYRIGHT HOLDERS AND CONTRIBUTORS "AS IS" AND ANY EXPRESS OR IMPLIED WARRANTIES, INCLUDING, BUT NOT LIMITED TO, THE IMPLIED WARRANTIES OF MERCHANTABILITY AND FITNESS FOR A PARTICULAR PURPOSE ARE DISCLAIMED. IN NO EVENT SHALL THE COPYRIGHT OWNER OR CONTRIBUTORS BE LIABLE FOR ANY DIRECT, INDIRECT, INCIDENTAL, SPECIAL, EXEMPLARY, OR CONSEQUENTIAL DAMAGES (INCLUDING, BUT NOT LIMITED TO, PROCUREMENT OF SUBSTITUTE GOODS OR SERVICES; LOSS OF USE, DATA, OR PROFITS; OR BUSINESS INTERRUPTION) HOWEVER CAUSED AND ON ANY THEORY OF LIABILITY, WHETHER IN CONTRACT, STRICT LIABILITY, OR TORT (INCLUDING NEGLIGENCE OR OTHERWISE) ARISING IN ANY WAY OUT OF THE USE OF THIS SOFTWARE, EVEN IF ADVISED OF THE POSSIBILITY OF SUCH DAMAGE.

Copyright (c) 2003-2004, Mark Borgerding
Lots of modifications by Jean-Marc Valin
Copyright (c) 2005-2007, Xiph.Org Foundation
Copyright (c) 2008, Xiph.Org Foundation, CSIRO

All rights reserved.

Redistribution and use in source and binary forms, with or without modification, are permitted provided that the following conditions are met:

- * Redistributions of source code must retain the above copyright notice, this list of conditions and the following disclaimer.
- * Redistributions in binary form must reproduce the above copyright notice, this list of conditions and the following disclaimer in the documentation and/or other materials provided with the distribution.

THIS SOFTWARE IS PROVIDED BY THE COPYRIGHT HOLDERS AND CONTRIBUTORS "AS IS" AND ANY EXPRESS OR IMPLIED WARRANTIES, INCLUDING, BUT NOT LIMITED TO, THE IMPLIED WARRANTIES OF MERCHANTABILITY AND FITNESS FOR A PARTICULAR PURPOSE ARE DISCLAIMED. IN NO EVENT SHALL THE COPYRIGHT OWNER OR CONTRIBUTORS BE LIABLE FOR ANY DIRECT, INDIRECT, INCIDENTAL, SPECIAL, EXEMPLARY, OR CONSEQUENTIAL DAMAGES (INCLUDING, BUT NOT LIMITED TO, PROCUREMENT OF SUBSTITUTE GOODS OR SERVICES; LOSS OF USE, DATA, OR PROFITS; OR BUSINESS INTERRUPTION) HOWEVER CAUSED AND ON ANY THEORY OF LIABILITY, WHETHER IN CONTRACT, STRICT LIABILITY, OR TORT (INCLUDING NEGLIGENCE OR OTHERWISE) ARISING IN ANY WAY OUT OF THE USE OF THIS SOFTWARE, EVEN IF ADVISED OF THE POSSIBILITY OF SUCH DAMAGE.* /

Copyright (c) 2003-2004, Mark Borgerding
Lots of modifications by Jean-Marc Valin
Copyright (c) 2005-2007, Xiph.Org Foundation
Copyright (c) 2008, Xiph.Org Foundation, CSIRO

All rights reserved.

Redistribution and use in source and binary forms, with or without modification, are permitted provided that the following conditions are met:

* Redistributions of source code must retain the above copyright notice, this list of conditions and the following disclaimer.

* Redistributions in binary form must reproduce the above copyright notice, this list of conditions and the following disclaimer in the documentation and/or other materials provided with the distribution.

THIS SOFTWARE IS PROVIDED BY THE COPYRIGHT HOLDERS AND CONTRIBUTORS "AS IS" AND ANY EXPRESS OR IMPLIED WARRANTIES, INCLUDING, BUT NOT LIMITED TO, THE IMPLIED WARRANTIES OF MERCHANTABILITY AND FITNESS FOR A PARTICULAR PURPOSE ARE DISCLAIMED. IN NO EVENT SHALL THE COPYRIGHT OWNER OR CONTRIBUTORS BE LIABLE FOR ANY DIRECT, INDIRECT, INCIDENTAL, SPECIAL, EXEMPLARY, OR CONSEQUENTIAL DAMAGES (INCLUDING, BUT NOT LIMITED TO, PROCUREMENT OF SUBSTITUTE GOODS OR SERVICES; LOSS OF USE, DATA, OR PROFITS; OR BUSINESS INTERRUPTION) HOWEVER CAUSED AND ON ANY THEORY OF LIABILITY, WHETHER IN CONTRACT, STRICT LIABILITY, OR TORT (INCLUDING NEGLIGENCE OR OTHERWISE) ARISING IN ANY WAY OUT OF THE USE OF THIS SOFTWARE, EVEN IF ADVISED OF THE POSSIBILITY OF SUCH DAMAGE.

Copyright (c) 2007 CSIRO

Copyright (c) 2007-2009 Xiph.Org Foundation

Written by Jean-Marc Valin

Redistribution and use in source and binary forms, with or without modification, are permitted provided that the following conditions are met:

– Redistributions of source code must retain the above copyright notice, this list of conditions and the following disclaimer.

– Redistributions in binary form must reproduce the above copyright notice, this list of conditions and the following disclaimer in the documentation and/or other materials provided with the distribution.

THIS SOFTWARE IS PROVIDED BY THE COPYRIGHT HOLDERS AND CONTRIBUTORS "AS IS" AND ANY EXPRESS OR IMPLIED WARRANTIES, INCLUDING, BUT NOT LIMITED TO, THE IMPLIED WARRANTIES OF MERCHANTABILITY AND FITNESS FOR A PARTICULAR PURPOSE ARE DISCLAIMED. IN NO EVENT SHALL THE COPYRIGHT OWNER OR CONTRIBUTORS BE LIABLE FOR ANY DIRECT, INDIRECT, INCIDENTAL, SPECIAL, EXEMPLARY, OR CONSEQUENTIAL DAMAGES (INCLUDING, BUT NOT LIMITED TO, PROCUREMENT OF SUBSTITUTE GOODS OR SERVICES; LOSS OF USE, DATA, OR PROFITS; OR BUSINESS INTERRUPTION) HOWEVER CAUSED AND ON ANY THEORY OF LIABILITY, WHETHER IN CONTRACT, STRICT LIABILITY, OR TORT (INCLUDING NEGLIGENCE OR OTHERWISE) ARISING IN ANY WAY OUT OF THE USE OF THIS SOFTWARE, EVEN IF ADVISED OF THE POSSIBILITY OF SUCH DAMAGE.

Copyright (c) 2002-2008 Jean-Marc Valin

Copyright (c) 2007-2008 CSIRO

Copyright (c) 2007-2009 Xiph.Org Foundation

Written by Jean-Marc Valin

Redistribution and use in source and binary forms, with or without modification, are permitted provided that the following conditions are met:

- Redistributions of source code must retain the above copyright notice, this list of conditions and the following disclaimer.
- Redistributions in binary form must reproduce the above copyright notice, this list of conditions and the following disclaimer in the documentation and/or other materials provided with the distribution.

THIS SOFTWARE IS PROVIDED BY THE COPYRIGHT HOLDERS AND CONTRIBUTORS ``AS IS'' AND ANY EXPRESS OR IMPLIED WARRANTIES, INCLUDING, BUT NOT LIMITED TO, THE IMPLIED WARRANTIES OF MERCHANTABILITY AND FITNESS FOR A PARTICULAR PURPOSE ARE DISCLAIMED. IN NO EVENT SHALL THE COPYRIGHT OWNER OR CONTRIBUTORS BE LIABLE FOR ANY DIRECT, INDIRECT, INCIDENTAL, SPECIAL, EXEMPLARY, OR CONSEQUENTIAL DAMAGES (INCLUDING, BUT NOT LIMITED TO, PROCUREMENT OF SUBSTITUTE GOODS OR SERVICES; LOSS OF USE, DATA, OR PROFITS; OR BUSINESS INTERRUPTION) HOWEVER CAUSED AND ON ANY THEORY OF LIABILITY, WHETHER IN CONTRACT, STRICT LIABILITY, OR TORT (INCLUDING NEGLIGENCE OR OTHERWISE) ARISING IN ANY WAY OUT OF THE USE OF THIS SOFTWARE, EVEN IF ADVISED OF THE POSSIBILITY OF SUCH DAMAGE.

Copyright (c) 2007-2008 CSIRO
Copyright (c) 2007-2008 Xiph.Org Foundation
Written by Jean-Marc Valin

Redistribution and use in source and binary forms, with or without modification, are permitted provided that the following conditions are met:

- Redistributions of source code must retain the above copyright notice, this list of conditions and the following disclaimer.
- Redistributions in binary form must reproduce the above copyright notice, this list of conditions and the following disclaimer in the documentation and/or other materials provided with the distribution.

THIS SOFTWARE IS PROVIDED BY THE COPYRIGHT HOLDERS AND CONTRIBUTORS ``AS IS'' AND ANY EXPRESS OR IMPLIED WARRANTIES, INCLUDING, BUT NOT LIMITED TO, THE IMPLIED WARRANTIES OF MERCHANTABILITY AND FITNESS FOR A PARTICULAR PURPOSE ARE DISCLAIMED. IN NO EVENT SHALL THE COPYRIGHT OWNER OR CONTRIBUTORS BE LIABLE FOR ANY DIRECT, INDIRECT, INCIDENTAL, SPECIAL, EXEMPLARY, OR CONSEQUENTIAL DAMAGES (INCLUDING, BUT NOT LIMITED TO, PROCUREMENT OF SUBSTITUTE GOODS OR SERVICES; LOSS OF USE, DATA, OR PROFITS; OR BUSINESS INTERRUPTION) HOWEVER CAUSED AND ON ANY THEORY OF LIABILITY, WHETHER IN CONTRACT, STRICT LIABILITY, OR TORT (INCLUDING NEGLIGENCE OR OTHERWISE) ARISING IN ANY WAY OUT OF THE USE OF THIS SOFTWARE, EVEN IF ADVISED OF THE POSSIBILITY OF SUCH DAMAGE.

Copyright (c) 2001-2008 Timothy B. Terriberry
Copyright (c) 2008-2009 Xiph.Org Foundation

Redistribution and use in source and binary forms, with or without modification, are permitted provided that the following conditions are met:

- Redistributions of source code must retain the above copyright notice, this list of conditions and the following disclaimer.

- Redistributions in binary form must reproduce the above copyright notice, this list of conditions and the following disclaimer in the documentation and/or other materials provided with the distribution.

THIS SOFTWARE IS PROVIDED BY THE COPYRIGHT HOLDERS AND CONTRIBUTORS "AS IS" AND ANY EXPRESS OR IMPLIED WARRANTIES, INCLUDING, BUT NOT LIMITED TO, THE IMPLIED WARRANTIES OF MERCHANTABILITY AND FITNESS FOR A PARTICULAR PURPOSE ARE DISCLAIMED. IN NO EVENT SHALL THE COPYRIGHT OWNER OR CONTRIBUTORS BE LIABLE FOR ANY DIRECT, INDIRECT, INCIDENTAL, SPECIAL, EXEMPLARY, OR CONSEQUENTIAL DAMAGES (INCLUDING, BUT NOT LIMITED TO, PROCUREMENT OF SUBSTITUTE GOODS OR SERVICES; LOSS OF USE, DATA, OR PROFITS; OR BUSINESS INTERRUPTION) HOWEVER CAUSED AND ON ANY THEORY OF LIABILITY, WHETHER IN CONTRACT, STRICT LIABILITY, OR TORT (INCLUDING NEGLIGENCE OR OTHERWISE) ARISING IN ANY WAY OUT OF THE USE OF THIS SOFTWARE, EVEN IF ADVISED OF THE POSSIBILITY OF SUCH DAMAGE.

Copyright (c) 2010-2011 Xiph.Org Foundation, Skype Limited
Written by Jean-Marc Valin and Koen Vos

Redistribution and use in source and binary forms, with or without modification, are permitted provided that the following conditions are met:

- Redistributions of source code must retain the above copyright notice, this list of conditions and the following disclaimer.
- Redistributions in binary form must reproduce the above copyright notice, this list of conditions and the following disclaimer in the documentation and/or other materials provided with the distribution.

THIS SOFTWARE IS PROVIDED BY THE COPYRIGHT HOLDERS AND CONTRIBUTORS "AS IS" AND ANY EXPRESS OR IMPLIED WARRANTIES, INCLUDING, BUT NOT LIMITED TO, THE IMPLIED WARRANTIES OF MERCHANTABILITY AND FITNESS FOR A PARTICULAR PURPOSE ARE DISCLAIMED. IN NO EVENT SHALL THE COPYRIGHT OWNER OR CONTRIBUTORS BE LIABLE FOR ANY DIRECT, INDIRECT, INCIDENTAL, SPECIAL, EXEMPLARY, OR CONSEQUENTIAL DAMAGES (INCLUDING, BUT NOT LIMITED TO, PROCUREMENT OF SUBSTITUTE GOODS OR SERVICES; LOSS OF USE, DATA, OR PROFITS; OR BUSINESS INTERRUPTION) HOWEVER CAUSED AND ON ANY THEORY OF LIABILITY, WHETHER IN CONTRACT, STRICT LIABILITY, OR TORT (INCLUDING NEGLIGENCE OR OTHERWISE) ARISING IN ANY WAY OUT OF THE USE OF THIS SOFTWARE, EVEN IF ADVISED OF THE POSSIBILITY OF SUCH DAMAGE.

Copyright (c) 2007-2008 CSIRO
Copyright (c) 2007-2009 Xiph.Org Foundation
Copyright (c) 2008 Gregory Maxwell
Written by Jean-Marc Valin and Gregory Maxwell

Redistribution and use in source and binary forms, with or without modification, are permitted provided that the following conditions are met:

- Redistributions of source code must retain the above copyright notice, this list of conditions and the following disclaimer.
- Redistributions in binary form must reproduce the above copyright notice, this list of conditions and the following disclaimer in the documentation and/or other materials provided with the distribution.

THIS SOFTWARE IS PROVIDED BY THE COPYRIGHT HOLDERS AND CONTRIBUTORS ``AS IS'' AND ANY EXPRESS OR IMPLIED WARRANTIES, INCLUDING, BUT NOT LIMITED TO, THE IMPLIED WARRANTIES OF MERCHANTABILITY AND FITNESS FOR A PARTICULAR PURPOSE ARE DISCLAIMED. IN NO EVENT SHALL THE COPYRIGHT OWNER OR CONTRIBUTORS BE LIABLE FOR ANY DIRECT, INDIRECT, INCIDENTAL, SPECIAL, EXEMPLARY, OR CONSEQUENTIAL DAMAGES (INCLUDING, BUT NOT LIMITED TO, PROCUREMENT OF SUBSTITUTE GOODS OR SERVICES; LOSS OF USE, DATA, OR PROFITS; OR BUSINESS INTERRUPTION) HOWEVER CAUSED AND ON ANY THEORY OF LIABILITY, WHETHER IN CONTRACT, STRICT LIABILITY, OR TORT (INCLUDING NEGLIGENCE OR OTHERWISE) ARISING IN ANY WAY OUT OF THE USE OF THIS SOFTWARE, EVEN IF ADVISED OF THE POSSIBILITY OF SUCH DAMAGE.

Copyright (c) 2007-2008 CSIRO
Copyright (c) 2007-2009 Xiph.Org Foundation
Copyright (c) 2008-2012 Gregory Maxwell
Written by Jean-Marc Valin and Gregory Maxwell

Redistribution and use in source and binary forms, with or without modification, are permitted provided that the following conditions are met:

- Redistributions of source code must retain the above copyright notice, this list of conditions and the following disclaimer.
- Redistributions in binary form must reproduce the above copyright notice, this list of conditions and the following disclaimer in the documentation and/or other materials provided with the distribution.

THIS SOFTWARE IS PROVIDED BY THE COPYRIGHT HOLDERS AND CONTRIBUTORS ``AS IS'' AND ANY EXPRESS OR IMPLIED WARRANTIES, INCLUDING, BUT NOT LIMITED TO, THE IMPLIED WARRANTIES OF MERCHANTABILITY AND FITNESS FOR A PARTICULAR PURPOSE ARE DISCLAIMED. IN NO EVENT SHALL THE COPYRIGHT OWNER OR CONTRIBUTORS BE LIABLE FOR ANY DIRECT, INDIRECT, INCIDENTAL, SPECIAL, EXEMPLARY, OR CONSEQUENTIAL DAMAGES (INCLUDING, BUT NOT LIMITED TO, PROCUREMENT OF SUBSTITUTE GOODS OR SERVICES; LOSS OF USE, DATA, OR PROFITS; OR BUSINESS INTERRUPTION) HOWEVER CAUSED AND ON ANY THEORY OF LIABILITY, WHETHER IN CONTRACT, STRICT LIABILITY, OR TORT (INCLUDING NEGLIGENCE OR OTHERWISE) ARISING IN ANY WAY OUT OF THE USE OF THIS SOFTWARE, EVEN IF ADVISED OF THE POSSIBILITY OF SUCH DAMAGE.

Copyright (c) 2012 Xiph.Org Foundation
Written by Jean-Marc Valin

Redistribution and use in source and binary forms, with or without modification, are permitted provided that the following conditions are met:

- Redistributions of source code must retain the above copyright notice, this list of conditions and the following disclaimer.
- Redistributions in binary form must reproduce the above copyright notice, this list of conditions and the following disclaimer in the documentation and/or other materials provided with the distribution.

THIS SOFTWARE IS PROVIDED BY THE COPYRIGHT HOLDERS AND CONTRIBUTORS ``AS IS'' AND ANY EXPRESS OR IMPLIED WARRANTIES, INCLUDING, BUT NOT LIMITED TO, THE IMPLIED WARRANTIES OF MERCHANTABILITY AND FITNESS FOR A PARTICULAR PURPOSE ARE DISCLAIMED. IN NO EVENT SHALL THE COPYRIGHT OWNER OR CONTRIBUTORS BE LIABLE FOR ANY DIRECT, INDIRECT, INCIDENTAL, SPECIAL, EXEMPLARY, OR CONSEQUENTIAL DAMAGES (INCLUDING, BUT NOT LIMITED TO, PROCUREMENT OF SUBSTITUTE GOODS OR SERVICES; LOSS OF USE, DATA, OR PROFITS; OR BUSINESS INTERRUPTION) HOWEVER CAUSED AND ON ANY THEORY OF LIABILITY, WHETHER IN CONTRACT, STRICT LIABILITY, OR TORT (INCLUDING NEGLIGENCE OR OTHERWISE) ARISING IN ANY WAY OUT OF THE USE OF THIS SOFTWARE, EVEN IF ADVISED OF THE POSSIBILITY OF SUCH DAMAGE.

(C) COPYRIGHT 1994-2002 Xiph.Org Foundation
Modified by Jean-Marc Valin

Redistribution and use in source and binary forms, with or without modification, are permitted provided that the following conditions are met:

- Redistributions of source code must retain the above copyright notice, this list of conditions and the following disclaimer.
- Redistributions in binary form must reproduce the above copyright notice, this list of conditions and the following disclaimer in the documentation and/or other materials provided with the distribution.

THIS SOFTWARE IS PROVIDED BY THE COPYRIGHT HOLDERS AND CONTRIBUTORS ``AS IS'' AND ANY EXPRESS OR IMPLIED WARRANTIES, INCLUDING, BUT NOT LIMITED TO, THE IMPLIED WARRANTIES OF MERCHANTABILITY AND FITNESS FOR A PARTICULAR PURPOSE ARE DISCLAIMED. IN NO EVENT SHALL THE COPYRIGHT OWNER OR CONTRIBUTORS BE LIABLE FOR ANY DIRECT, INDIRECT, INCIDENTAL, SPECIAL, EXEMPLARY, OR CONSEQUENTIAL DAMAGES (INCLUDING, BUT NOT LIMITED TO, PROCUREMENT OF SUBSTITUTE GOODS OR SERVICES; LOSS OF USE, DATA, OR PROFITS; OR BUSINESS INTERRUPTION) HOWEVER CAUSED AND ON ANY THEORY OF LIABILITY, WHETHER IN CONTRACT, STRICT LIABILITY, OR TORT (INCLUDING NEGLIGENCE OR OTHERWISE) ARISING IN ANY WAY OUT OF THE USE OF THIS SOFTWARE, EVEN IF ADVISED OF THE POSSIBILITY OF SUCH DAMAGE.

Copyright (C) 2007 Jean-Marc Valin

Redistribution and use in source and binary forms, with or without modification, are permitted provided that the following conditions are met:

1. Redistributions of source code must retain the above copyright notice, this list of conditions and the following disclaimer.
2. Redistributions in binary form must reproduce the above copyright notice, this list of conditions and the following disclaimer in the documentation and/or other materials provided with the distribution.

THIS SOFTWARE IS PROVIDED BY THE AUTHOR ``AS IS'' AND ANY EXPRESS OR IMPLIED WARRANTIES, INCLUDING, BUT NOT LIMITED TO, THE IMPLIED WARRANTIES OF MERCHANTABILITY AND FITNESS FOR A PARTICULAR PURPOSE ARE DISCLAIMED. IN NO EVENT SHALL THE AUTHOR BE LIABLE FOR ANY DIRECT, INDIRECT, INCIDENTAL, SPECIAL, EXEMPLARY, OR CONSEQUENTIAL DAMAGES (INCLUDING, BUT NOT LIMITED TO, PROCUREMENT OF SUBSTITUTE GOODS OR SERVICES; LOSS OF USE, DATA, OR PROFITS; OR

BUSINESS INTERRUPTION) HOWEVER CAUSED AND ON ANY THEORY OF LIABILITY, WHETHER IN CONTRACT, STRICT LIABILITY, OR TORT (INCLUDING NEGLIGENCE OR OTHERWISE) ARISING IN ANY WAY OUT OF THE USE OF THIS SOFTWARE, EVEN IF ADVISED OF THE POSSIBILITY OF SUCH DAMAGE.

Copyright (c) 2007-2008 CSIRO
Copyright (c) 2007-2009 Xiph.Org Foundation
Written by Jean-Marc Valin

Redistribution and use in source and binary forms, with or without modification, are permitted provided that the following conditions are met:

- Redistributions of source code must retain the above copyright notice, this list of conditions and the following disclaimer.
- Redistributions in binary form must reproduce the above copyright notice, this list of conditions and the following disclaimer in the documentation and/or other materials provided with the distribution.

THIS SOFTWARE IS PROVIDED BY THE COPYRIGHT HOLDERS AND CONTRIBUTORS ``AS IS'' AND ANY EXPRESS OR IMPLIED WARRANTIES, INCLUDING, BUT NOT LIMITED TO, THE IMPLIED WARRANTIES OF MERCHANTABILITY AND FITNESS FOR A PARTICULAR PURPOSE ARE DISCLAIMED. IN NO EVENT SHALL THE COPYRIGHT OWNER OR CONTRIBUTORS BE LIABLE FOR ANY DIRECT, INDIRECT, INCIDENTAL, SPECIAL, EXEMPLARY, OR CONSEQUENTIAL DAMAGES (INCLUDING, BUT NOT LIMITED TO, PROCUREMENT OF SUBSTITUTE GOODS OR SERVICES; LOSS OF USE, DATA, OR PROFITS; OR BUSINESS INTERRUPTION) HOWEVER CAUSED AND ON ANY THEORY OF LIABILITY, WHETHER IN CONTRACT, STRICT LIABILITY, OR TORT (INCLUDING NEGLIGENCE OR OTHERWISE) ARISING IN ANY WAY OUT OF THE USE OF THIS SOFTWARE, EVEN IF ADVISED OF THE POSSIBILITY OF SUCH DAMAGE.

Copyright (C) 2002-2003 Jean-Marc Valin
Copyright (C) 2007-2009 Xiph.Org Foundation

Redistribution and use in source and binary forms, with or without modification, are permitted provided that the following conditions are met:

- Redistributions of source code must retain the above copyright notice, this list of conditions and the following disclaimer.
- Redistributions in binary form must reproduce the above copyright notice, this list of conditions and the following disclaimer in the documentation and/or other materials provided with the distribution.

THIS SOFTWARE IS PROVIDED BY THE COPYRIGHT HOLDERS AND CONTRIBUTORS ``AS IS'' AND ANY EXPRESS OR IMPLIED WARRANTIES, INCLUDING, BUT NOT LIMITED TO, THE IMPLIED WARRANTIES OF MERCHANTABILITY AND FITNESS FOR A PARTICULAR PURPOSE ARE DISCLAIMED. IN NO EVENT SHALL THE COPYRIGHT OWNER OR CONTRIBUTORS BE LIABLE FOR ANY DIRECT, INDIRECT, INCIDENTAL, SPECIAL, EXEMPLARY, OR CONSEQUENTIAL DAMAGES (INCLUDING, BUT NOT LIMITED TO, PROCUREMENT OF SUBSTITUTE GOODS OR SERVICES; LOSS OF USE, DATA, OR PROFITS; OR BUSINESS INTERRUPTION) HOWEVER CAUSED AND ON ANY THEORY OF LIABILITY, WHETHER IN CONTRACT, STRICT LIABILITY, OR TORT (INCLUDING NEGLIGENCE OR OTHERWISE) ARISING IN ANY WAY OUT OF THE USE OF THIS SOFTWARE, EVEN IF ADVISED OF THE POSSIBILITY OF SUCH DAMAGE.

EU

Bosch Sicherheitssysteme GmbH
Robert-Bosch-Platz 1
70839 Gerlingen
Germany

Mexico

Robert Bosch de R.L de C.V.
Calle Robert Bosch No. Ext. 405
C.P.50071
Zona industrial Toluca
Mexico
Phone: +52 722 279 2300

UK

Robert Bosch Ltd.
Broadwater Park
North Orbital Road
Uxbridge UB9 5HJ
UK

Disposal

For use in France: Sorting Info label (Info-tri)



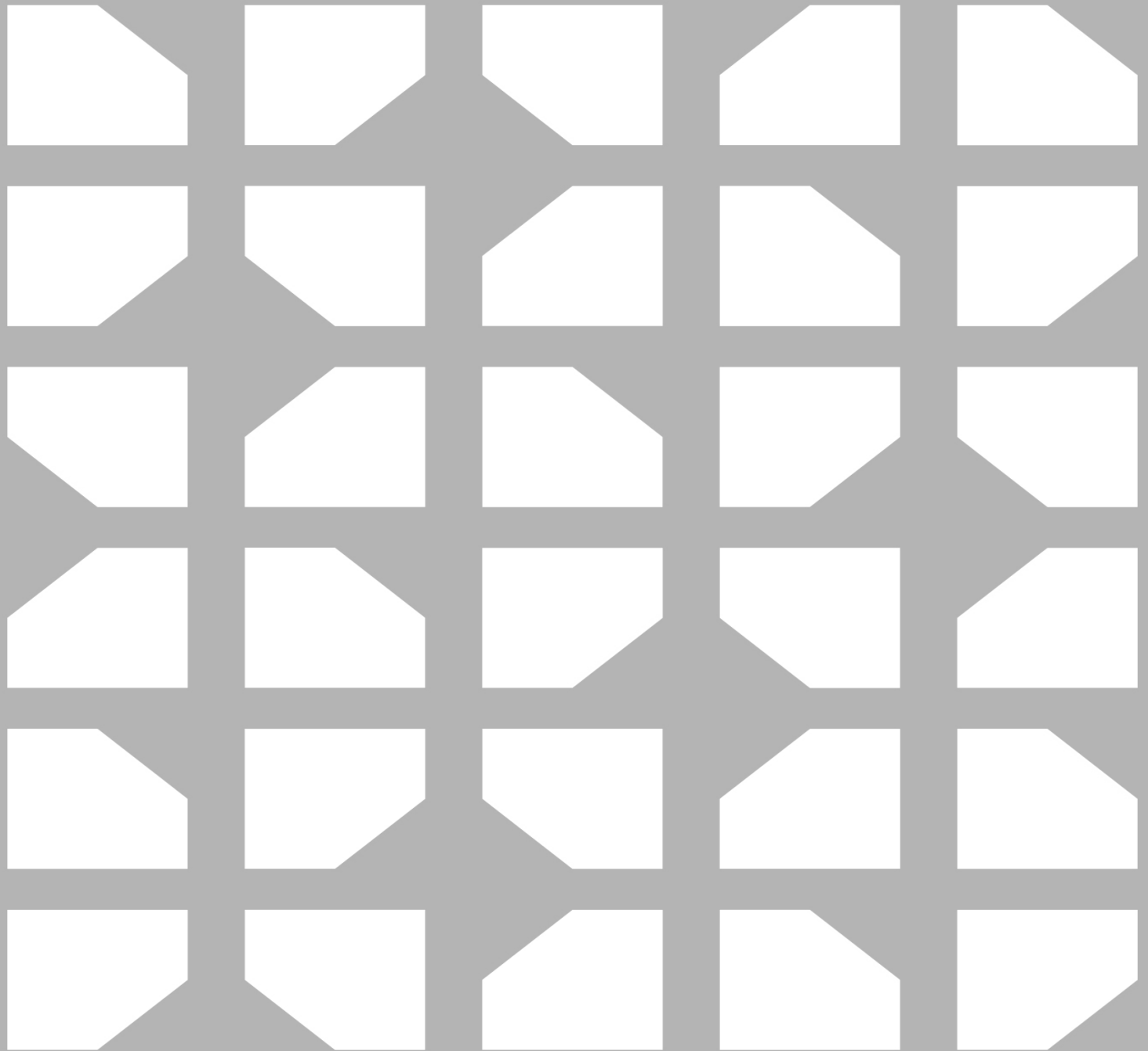

Bosch Security Systems, LLC

130 Pennell Parkway

Fairport, NY 14450

USA

www.electrovoice.com

© Bosch Security Systems, LLC, 2025

EU importer:

Bosch Sicherheitssysteme GmbH

Robert-Bosch-Platz 1

70839 Gerlingen

Germany

© Bosch Sicherheitssysteme GmbH, 2025

202511201527