

datavideo

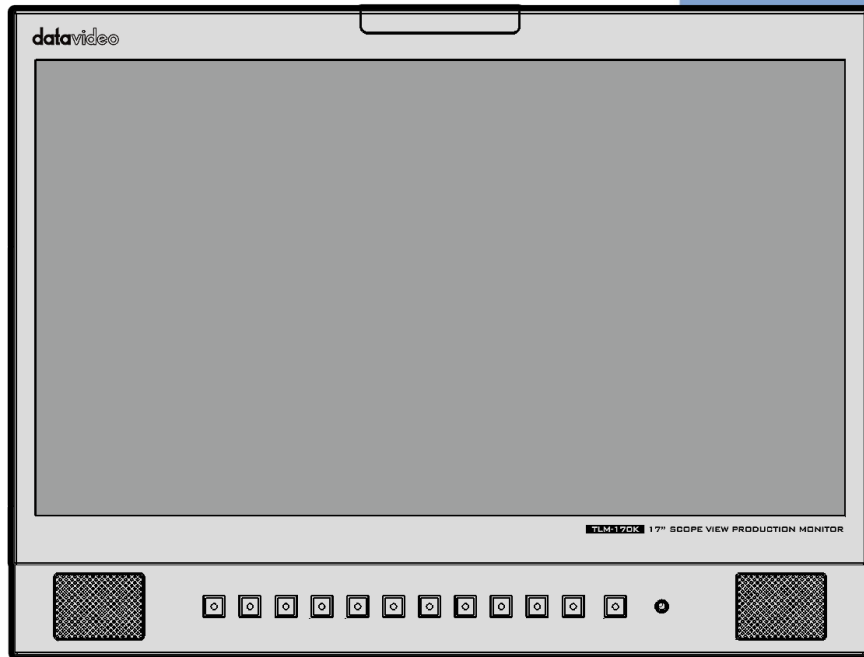

17" SCOPEVIEW
PRODUCTION MONITOR

TLM-170K / TLM-170KM
/ TLM-170KR

Instruction Manual

www.datavideo.com

Table of Contents

FCC COMPLIANCE STATEMENT	4
WARNINGS AND PRECAUTIONS	4
WARRANTY	5
STANDARD WARRANTY	5
FIVE YEAR WARRANTY	5
DISPOSAL.....	6
1. INTRODUCTION.....	7
FEATURES.....	7
MODEL TYPES.....	7
2. ASSEMBLING.....	8
3. CONNECTIONS AND CONTROLS.....	10
FRONT PANEL.....	10
REAR PANEL.....	13
4. OSD MENU.....	14
PICTURE.....	19
<i>Brightness</i>	19
<i>Contrast</i>	19
<i>Saturation</i>	19
<i>Tint</i>	19
<i>Sharpness</i>	19
<i>HDMI RGB Range</i>	19
<i>HDMI EDID</i>	19
<i>Color Space</i>	19
<i>Camera Log</i>	20
<i>Def. Log</i>	20
<i>User Log</i>	20
<i>Gamma</i>	21
<i>HDR</i>	21
<i>Back Light</i>	21
<i>Color Temperature</i>	21
MARKER	22
<i>Center Marker</i>	22
<i>Center Marker Size</i>	22
<i>Aspect Marker</i>	22
<i>Safety Marker</i>	22
<i>Marker Color</i>	23
<i>Aspect MAT</i>	23
<i>Thickness</i>	23
<i>User Marker H1/H2</i>	23
<i>User Marker V1/V2</i>	23
FUNCTION	23
<i>Scan</i>	23
<i>Aspect</i>	24
<i>Overscan</i>	24
<i>H/V Delay</i>	25
<i>Check Field</i>	25
<i>Zoom</i>	25
<i>Freeze</i>	25
WAVEFORM.....	25
<i>Waveform</i>	26
<i>Vector</i>	27
<i>Transparency</i>	27

<i>Peaking filter</i>	27
<i>False Color</i>	28
<i>False Color Table</i>	29
<i>Exposure</i>	30
<i>Histogram</i>	31
<i>Time Code</i>	32
AUDIO	33
<i>Volume and Level Meter</i>	33
<i>Audio Vector</i>	33
<i>Audio Vector CH (HDMI)</i>	33
<i>Audio Vector CH (SDI)</i>	33
<i>Audio Left Out</i>	33
<i>Audio Right Out</i>	34
SYSTEM.....	34
<i>Language</i>	34
<i>Color Bar</i>	34
<i>Color Bar Mode</i>	34
<i>OSD Timer</i>	34
<i>OSD Transparency</i>	34
<i>OSD H Position</i>	35
<i>OSD V Position</i>	35
<i>Fan</i>	35
<i>Color Calibration</i>	35
<i>Comparison EN</i>	35
<i>Reset</i>	35
5. COLOR MANAGEMENT SYSTEM – CALIBRATION PROCESS	36
DEVICE SETUP	36
SOFTWARE SETUP	38
6. FIRMWARE UPDATE	46
7. DIMENSIONS	48
8. SPECIFICATIONS	49
SERVICE AND SUPPORT	52

Disclaimer of Product & Services

The information offered in this instruction manual is intended as a guide only. At all times, Datavideo Technologies will try to give correct, complete and suitable information. However, Datavideo Technologies cannot exclude that some information in this manual, from time to time, may not be correct or may be incomplete. This manual may contain typing errors, omissions or incorrect information. Datavideo Technologies always recommend that you double check the information in this document for accuracy before making any purchase decision or using the product. Datavideo Technologies is not responsible for any omissions or errors, or for any subsequent loss or damage caused by using the information contained within this manual. Further advice on the content of this manual or on the product can be obtained by contacting your local Datavideo Office or dealer.

FCC Compliance Statement

This device complies with part 15 of the FCC rules. Operation is subject to the following two conditions:

1. This device may not cause harmful interference, and
2. This device must accept any interference received, including interference that may cause undesired operation.

Warnings and Precautions

1. Read all of these warnings and save them for later reference.
2. Follow all warnings and instructions marked on this unit.
3. Unplug this unit from the wall outlet before cleaning. Do not use liquid or aerosol cleaners. Use a damp cloth for cleaning.
4. Do not use this unit in or near water.
5. Do not place this unit on an unstable cart, stand, or table. The unit may fall, causing serious damage.
6. Slots and openings on the cabinet top, back, and bottom are provided for ventilation. To ensure safe and reliable operation of this unit, and to protect it from overheating, do not block or cover these openings. Do not place this unit on a bed, sofa, rug, or similar surface, as the ventilation openings on the bottom of the cabinet will be blocked. This unit should never be placed near or over a heat register or radiator. This unit should not be placed in a built-in installation unless proper ventilation is provided.
7. This product should only be operated from the type of power source indicated on the marking label of the AC adapter. If you are not sure of the type of power available, consult your Datavideo dealer or your local power company.
8. Do not allow anything to rest on the power cord. Do not locate this unit where the power cord will be walked on, rolled over, or otherwise stressed.
9. If an extension cord must be used with this unit, make sure that the total of the ampere ratings on the products plugged into the extension cord do not exceed the extension cord rating.
10. Make sure that the total amperes of all the units that are plugged into a single wall outlet do not exceed 15 amperes.
11. Never push objects of any kind into this unit through the cabinet ventilation slots, as they may touch dangerous voltage points or short out parts that could result in risk of fire or electric shock. Never spill liquid of any kind onto or into this unit.
12. Except as specifically explained elsewhere in this manual, do not attempt to service this product yourself. Opening or removing covers that are marked "Do Not Remove" may expose you to dangerous voltage points or other risks, and will void your warranty. Refer all service issues to qualified service personnel.
13. Unplug this product from the wall outlet and refer to qualified service personnel under the following conditions:
 - a. When the power cord is damaged or frayed;
 - b. When liquid has spilled into the unit;
 - c. When the product has been exposed to rain or water;



- d. When the product does not operate normally under normal operating conditions. Adjust only those controls that are covered by the operating instructions in this manual; improper adjustment of other controls may result in damage to the unit and may often require extensive work by a qualified technician to restore the unit to normal operation;
- e. When the product has been dropped or the cabinet has been damaged;
- f. When the product exhibits a distinct change in performance, indicating a need for service.

Warranty

Standard Warranty

- Datavideo equipment is guaranteed against manufacturing defects for **one (1) year** from the date of purchase.
- A valid purchase invoice or other proof of purchase must be provided when requesting warranty service.
- The warranty period begins on the actual purchase date. If the purchase date cannot be verified, the warranty period will begin **thirty (30) days after shipment** from a Datavideo office.
- Non-Datavideo branded products (products without the Datavideo logo) are covered by a **one-year warranty** from the date of purchase.
- Damage caused by accident, misuse, unauthorized repair, or exposure to sand, grit, or water is **not covered** under warranty.
- Virus or malware infections on computer systems are **not covered** under warranty.
- Any issues caused by unauthorized third-party software installations that are not required by Datavideo systems are **not covered** under warranty.
- All shipping, mailing, or transportation costs, including insurance, are the responsibility of the owner unless otherwise stated.
- **Teleprompter glass is not covered** under warranty.
- Accessories, including **headphones, cables, batteries, metal parts, housings, protective cases, cable reels, and consumable items**, are **not covered** under warranty.
- Warranty is valid only in the country or region of purchase.
- All other claims **not explicitly stated** are not covered.
- Your statutory rights remain unaffected.

Five Year Warranty

- Starting January 1, 2026, all Datavideo products that are successfully registered on the Datavideo official website are eligible for a **free four-year extended warranty**, in addition to the standard one-year warranty, for a total of **five years of coverage**.
- **Only registrations completed through the Datavideo official website qualify** for the five-year warranty. Registrations completed through local Datavideo offices, resellers, or authorized distributors are **not eligible**.
- Certain parts with limited service life — including **LCD panels, DVD drives, hard drives, solid-state drives, SD cards, USB thumb drives, lighting equipment, non-PCIe cards, and third-**



party PC components — are covered by a **one-year warranty only** and are **not eligible** for the extended warranty.

- **Camera modules** are covered by a **three-year warranty from the date of purchase**.

Disposal

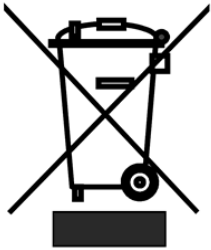

For EU Customers only - WEEE Marking

This symbol on the product or on its packaging indicates that this product must not be disposed of with your other household waste. Instead, it is your responsibility to dispose of your waste equipment by handing it over to a designated collection point for the recycling of waste electrical and electronic equipment. The separate collection and recycling of your waste equipment at the time of disposal will help to conserve natural resources and ensure that it is recycled in a manner that protects human health and the environment. For more information about where you can drop off your waste equipment for recycling, please contact your local city office, your household waste disposal service or the shop where you purchased the product.



CE Marking is the symbol as shown on the left of this page. The letters "CE" are the abbreviation of French phrase "Conformité Européene" which literally means "European Conformity". The term initially used was "EC Mark" and it was officially replaced by "CE Marking" in the Directive 93/68/EEC in 1993. "CE Marking" is now used in all EU official documents.

1. Introduction



The TLM-170K offers a UHD 3840 x 2160 LCD Panel which provides a wide viewing angle of 178°, 300 cd/m² brightness, and 1000:1 contrast ratio. It features a 12G SDI input and two HDMI 2.0 inputs with one loop through output allowing connection of up to DCI 4K and Ultra HD video sources.

The TLM-170K is equipped with various functions such as waveform, vector scope, false color filter, histogram, peaking filter, zoom, screen markers, etc. The TLM-170K has two HDR transfer functions which are HLG and SMPTE 2084. The color space includes options such as Rec 709 and DCI P3 Cinema. The TLM -170K is designed specifically for broadcast and field production applications.

Features

- DCI 4K/60p and UHD 4K/60p videos for both input and output
- 17" monitor with UHD 4K (3840 x 2160) LCD display
- Supports column (YRGB peak), time code, waveform, vector scope & audio level meter, peaking filter, zoom, pix to pix, overscan, check field, etc
- 12G-SDI video input with loop-through output
- HDMI 4K input with loop-through output
- Time Code Display (LTC/VITC)
- Four user-assignable function keys (F1, F2, F3, and F4)
- Safety Marker and Aspect Marker
- 1000:1 contrast ratio, 300 cd/m² brightness
- 178° Horizontal & Vertical wide viewing angle
- Individual adjustments of Brightness, Contrast, and Saturation.
- Color Match Conversion with Color Temperature Adjustment
- Front panel Headphone Jacks
- Tally light included.

Model Types

Model	TLM-170K	TLM-170KR	TLM-170KM
Image			
System	Desktop	7U Rack Mount	1U Mobile Tray Rack Mount

2. Assembling

If you would like to rest the monitor in an upright position on a flat surface, simply use the two riser blocks provided. Follow the steps outlined below to mount the monitor to a flat surface.

Step 1

Make sure you have all the parts listed in the table below in the product package. If you find missing items, please contact local Datavideo office or distributors.

No.	Part Name	Part No.	Q'ty	Use
1	Nylok Screw ISO Truss Head M4.0*8m/m Black (RoHS)	G0911D400811	4	Secure the monitor to riser blocks
2	Truss Head Self-Drilling Screw ϕ 5.0*15m/m Nickel Plated	G09111501503	4	Secure riser blocks to the desk
3	VP-927 TLM-170K Riser Block	G13309271201	2	

Step 2

Insert the monitor to the two riser blocks as shown in the diagram below then secure with truss head nylok screws (G0911D400811).

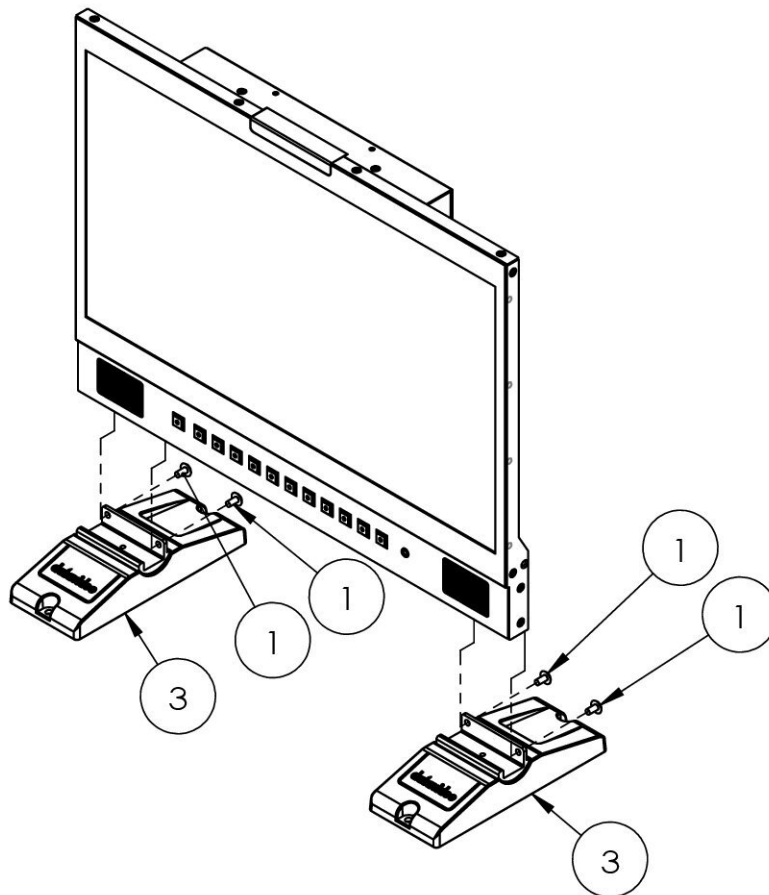

Step 3

As shown in the diagram below, use the truss head self-drilling screws (G09111501503) to secure the riser blocks to the desk.

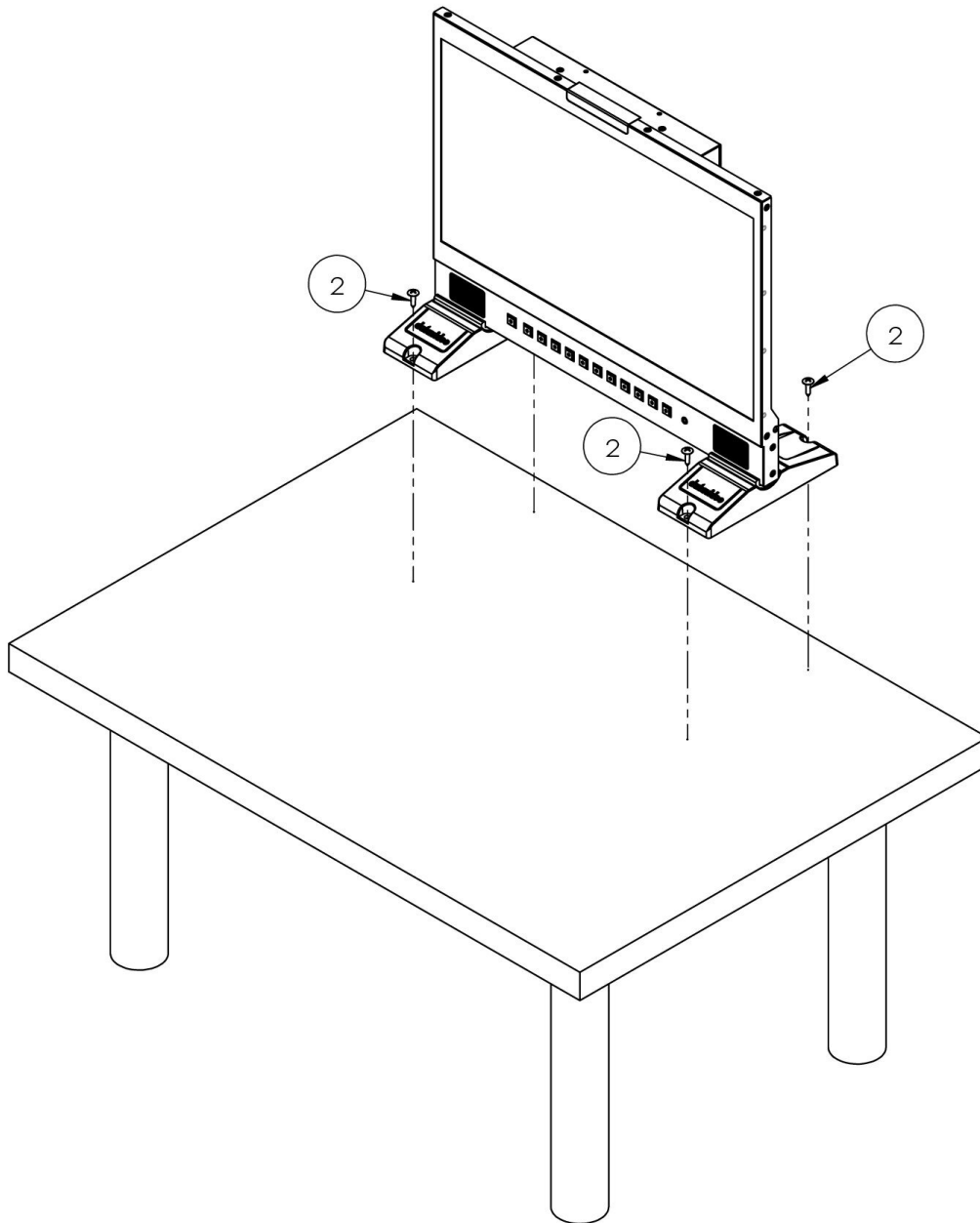





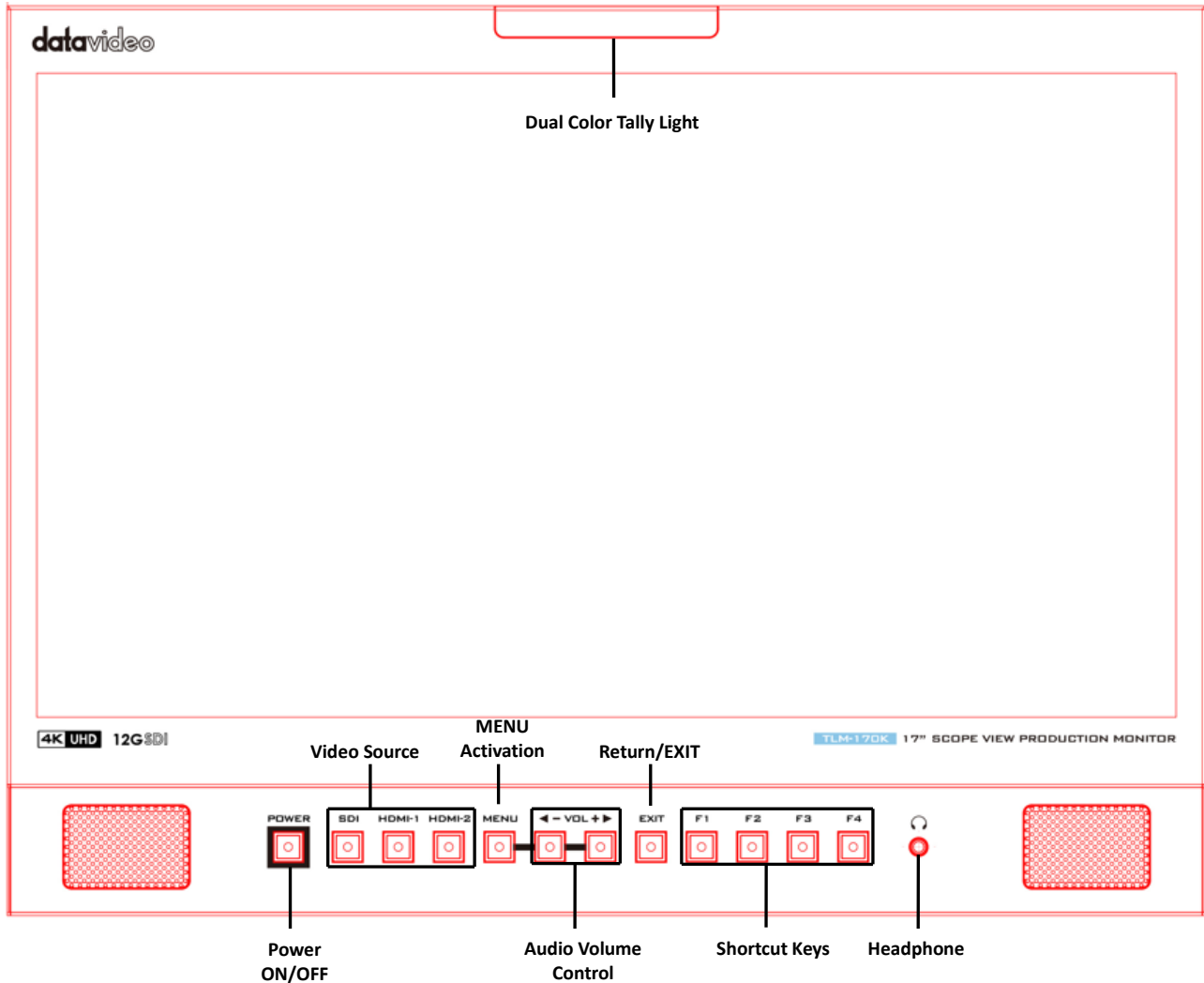

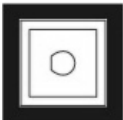
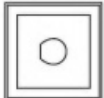
3. Connections and Controls

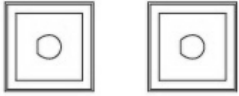
Front Panel

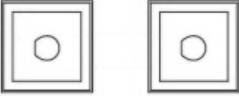

Buttons	Descriptions
<p>POWER</p> 	<p>Power ON/OFF</p> <p>This button powers the monitor ON/OFF. The main power switch is located at the rear of the TLM-170K.</p>
<p>SDI</p> 	<p>SDI Button</p> <p>Press once to enable the SDI video source on the monitor screen. You can connect the loop thru port (see Rear Panel) to a monitor to view the activated input video source.</p> <p>As the SDI video source is activated, the button LED will be turned ON.</p>

<p>HDMI-1 HDMI-2</p> 	<p>HDMI 1/2 Button Press once to enable the HDMI video source on the monitor screen. Please note that the two video sources cannot be enabled at the same time. You can connect the loop thru port (see Rear Panel) to a monitor to view the activated input video source. As the HDMI video source is activated, the corresponding button LED will be turned ON.</p>
<p>MENU</p> 	<p>MENU Button Press the MENU button to open the OSD menu. Once in the OSD menu, press the MENU button to make a selection.</p>
<p>◀ - VOL + ▶</p> 	<p>Audio Volume Adjustment Buttons Once in the OSD menu, navigate the menu or increase/decrease parameter values using the audio volume adjustment buttons.</p> <p>While NOT in the OSD menu, pressing either one of the audio volume adjustment buttons will open a Volume slide bar at the bottom of the screen. Then press the MENU button to switch to other setting options as listed below:</p> <ul style="list-style-type: none"> • Volume • Brightness • Contrast • Saturation • Tint • Sharpness • Exit <p>To adjust the parameter values, simply press the Vol- arrow button to decrease the value and the Vol+ arrow button to increase the value.</p>
<p>EXIT</p> 	<p>EXIT Button Return/Exit button</p>
<p>F 1</p>  <p>F 2</p> 	<p>F1 – F4 Shortcut Keys Press the F1-F4 shortcut keys to access the corresponding function setting menus. The default function setting menus are shown as follows: F1: Scan F2: Waveform F3: Aspect F4: Aspect Marker</p>

F3

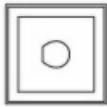

F4

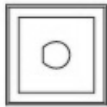

Customization of Button Functions

The user is allowed to customize or re-assign function setting menus to the F1-F4 shortcut keys. The customization steps are outlined as follows:

1. First press and hold one of the shortcut keys (F1-F4) for approximately 3-5 seconds until a pop-up function list appears on the monitor.
2. Press the left and right arrow keys of the audio volume adjustment buttons to move between options in the pop-up function list.
3. Press the menu button to assign the highlighted function setting menu to the shortcut key selected at step 1.
4. Press the EXIT button to close the pop-up function list.

The pop-up function list is shown below:

- **Center Marker**
- **Aspect Marker**
- **Safety Marker**
- **Overscan**
- **Scan**
- **Aspect**
- **Color Space**
- **Gamma**
- **Camera Log**
- **Check Field**
- **H/V Delay**
- **Freeze**
- **Color Bar**
- **False Color**
- **Exposure**
- **Histogram**
- **Waveform**
- **Vector**
- **Time Code**
- **Mute**
- **Level Meter**
- **Audio Vector**

Button Reset

To reset F1-F4 buttons to factory defaults, follow the steps outlined as follows:

1. Open the **OSD** menu, and navigate to **SYSTEM**.
2. Press the **MENU** button to enter the **SYSTEM** sub menu.
3. Move down to the **RESET** option which is selected by pressing the **MENU** button.
4. Press either the **VOL+** or **VOL-** button to enable the reset.

Note: The reset function resets all TLM-170K settings.



Headphone Jack

Once the 3.5mm headphone jack is connected, the **internal speaker will be automatically muted.**

Rear Panel

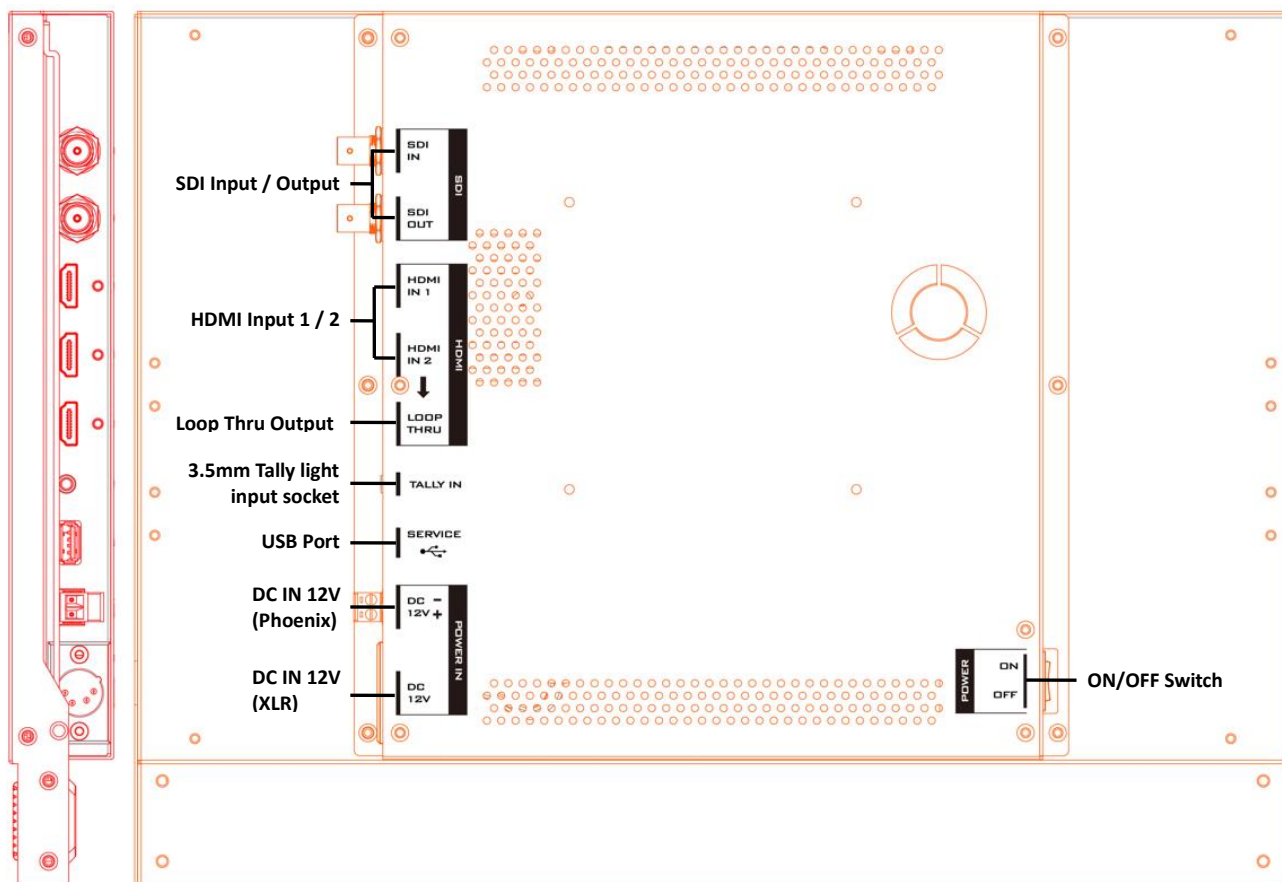

Ports	Descriptions
3.5mm Tally Light Input	Tally light input. The tip, ring and sleeve of the phone jack should be connected to tally red, tally green and the ground.
Loop Thru Output	A loop thru output of SDI and HDMI inputs.
HDMI Input 1/2	Connect HDMI video and audio source devices. HDMI 1: YUV420 not supported HDMI 2: YUV420 supported
USB 2.0 Port (SERVICE)	For firmware upgrade only; see Firmware Update for more information about firmware upgrade.
SDI Input / Output	1 SDI input/output pair
DC IN 12V	12 V power input (XLR/Phoenix Terminal)
Power ON/OFF Switch	TLM-170K's main power ON/OFF switch

4. OSD MENU

The TLM-170K can be set up using an OSD menu system. To display the **OSD menu** press the **MENU** button. This menu system is navigated using the **Left / Right** buttons. The **Left / Right** buttons are also used to change parameter values. Press the **MENU** button to select an option and the **EXIT** button to close the **OSD menu**.

Main Options	Sub Options	Parameters		
Picture	Brightness	0 – 100		
	Contrast	0 – 100		
	Saturation	0 – 100		
	Tint	0 – 100		
	Sharpness	0 – 100		
	HDMI RGB Range	Full		
		Limited		
	HDMI EDID	2K		
		4K		
	Color Space	BT2020		
		DCI-P3		
		EBU		
		Rec709		
		SMPTE-C		
		Native		
	Camera Log	Off		
		Def. Log		
		User Log		
	Def. Log	SLog2ToLC-709		
		SLog2ToLC-709TA		
		SLog2ToSLog2-709		
		SLog2ToCine+709		
		SLog3ToLC-709		
		SLog3ToLC-709TA		
		SLog3ToSLog2-709		
		SLog3ToCine+709		
		ArriLogCto709		
		ArriLogCtoP3DCI		
		ClogTo709		
		VLogToV709		
JLog To709HLG				
JLog To709PQ				
Z7 NLogTo709				
D780 NLogTo709				
User Log	No Data			
	User 1			
	User 2			
	User 3			
	User 4			
	User 5			

Main Options	Sub Options	Parameters	
	Gamma	User 6	
		Off	
		1.8	
		2.0	
		2.2	
		2.35	
		2.4	
		2.6	
		2.8	
	HDR	Off	
		ST 2084 300	
		ST 2084 1000	
		ST 2084 10000	
		HLG	
	Back Light	0 – 100	
	Color Temperature	3200°K	
		5500°K	
		6500°K	
		7500°K	
		9300°K	
		User Color	Red Gain
		Green Gain	0 – 255
		Blue Gain	0 – 255
		Red Offset	0 – 511
	Green Offset	0 – 511	
	Blue Offset	0 – 511	
Marker	Center Marker	ON	
		OFF	
	Center Marker Size	Small	
		Middle	
		Large	
	Aspect Marker	OFF	
		16:9	
		1.85:1	
		2.35:1	
		4:3	
		3:2	
		2.0X	
		2.0X MAG	
		Grid	
		User	
	Safety Market	OFF	
		95%	
		93%	
90%			
88%			
85%			

Main Options	Sub Options	Parameters	
	Marker Color	80%	
		Red	
		Green	
		Blue	
		White	
		Black	
	Aspect Mat	OFF	
		1	
		2	
		3	
		4	
		5	
		6	
		7	
	Thickness	1	
		2	
		3	
		4	
		5	
		6	
		7	
		8	
		9	
		10	
		11	
		12	
		13	
		14	
15			
User Marker H1	1 – 3840		
User Marker H2	1 – 3840		
User Marker V1	1 – 2160		
User Marker V2	1 – 2160		
Function	Scan	Zoom	
		Aspect	
		Pixel to Pixel	
	Aspect	Full	
		16:9	
		1.85:1	
		2.35:1	
		4:3	
		3:2	
		2.0X	
		2.0X MAG	
	Overscan	OFF	
		ON	
	H/V Delay	Off	
		H	

Main Options	Sub Options	Parameters	
		V	
		H/V	
	Check Field	OFF	
		Red	
		Green	
		Blue	
		Mono	
	Zoom	90%	
		80%	
		70%	
		60%	
		50%	
		40%	
		30%	
		20%	
	Freeze	OFF	
		ON	
	Waveform	Waveform	Multi
			Y
YCbCr			
RGB			
OFF			
Vector		OFF	
		ON	
Transparency		50%	
		25%	
		OFF	
Peaking		OFF	
		ON	
Peaking Color		Red	
		Green	
		Blue	
		White	
		Black	
Peaking Level		0 – 100	
False Color		OFF	
	Default		
	Spectrum		
	ARRI		
	RED		
False Color Table	OFF		
	ON		
Exposure	OFF		
	ON		
Exposure Level	50 – 100 IRE		
Histogram	OFF		
	Y		

Main Options	Sub Options	Parameters	
		RGB	
		Color	
	Time Code (SDI)	OFF	
		LTC	
VITC			
Audio	Volume	0 – 100	
	Level Meter	OFF	
		ON	
	Audio Vector	OFF	
		ON	
	Audio Vector CH (HDMI)	CH 1/2	
		CH 3/4	
		CH 5/6	
		CH 7/8	
	Audio Vector CH (SDI)	CH 1/2	
		CH 3/4	
		CH 5/6	
		CH 7/8	
		CH 9/10	
CH 11/12			
CH 13/14			
CH 15/16			
Audio Left Out	CH1 – 16 (SDI)		
	CH 1 – 8 (HDMI)		
Audio Right Out	CH1 – 16 (SDI)		
	CH 1 – 8 (HDMI)		
System	Language	English	
		Traditional Chinese	
		Simplified Chinese	
	Color Bar	OFF	
		100%	
		75%	
	Color Bar Mode	Rec601	
		Rec709	
		BT2020	
	OSD Timer	10s	
		20s	
		30s	
	OSD Transparency	OFF	
		25%	
50%			
OSD H Position	0 – 100		
OSD V Position	0 – 100		
Fan	Auto		
	ON		
	OFF		
Color Calibration	OFF		
	ON		

Main Options	Sub Options	Parameters	
	Comparison En	OFF	
		Gamma&HDR	
		Color Space	
		Camera Log	
	Reset	OFF	
		ON	

Picture

The TLM-170K allows you to adjust the basic image settings such as the **brightness, contrast, saturation, tint** and **sharpness**.

Advanced settings are **HDMI RGB range, color space, gamma correction, back light mode, back light level**, and **color temperature**.

Brightness

Adjust the brightness of the screen from 0 – 100.

Contrast

Adjust the contrast of the screen from 0 – 100.

Saturation

Adjust the saturation of the screen from 0 – 100.

Tint

Adjust the tint of the screen from 0 – 100.

Sharpness

Adjust the sharpness of the screen from 0 – 100.

HDMI RGB Range

This set the HDMI RGB Range.

RGB Full (0-255): PC Monitor

RGB Limited (16-235): Standard or HD TVs

HDMI EDID

The EDID learning function is only used when you experience any failures in playing audio and video correctly. You will be able to force the TLM-170K's receiving resolution by setting the EDID to either 2K or 4K so that the connected HDMI source outputs the maximum resolution defined in EDID.

Color Space

Select an option from the list below to provide details of the color primaries for interpretation of XYZ color space.

- BT2020
A 4K RGB color space that has a color gamut that is wider than all other RGB color spaces.
- EBU
EBU is another RGB color space encompassing 72% of the NTSC color space. EBU stands for the European Broadcasting Union which develops technical standards and regulations for broadcasting. DTV standards in Taiwan are developed based on the EBU standards.

- REC709
REC709 is the standard camera encoding color space for HDTV established by International Telecommunication Union in 1990.
- SMPTE-C
SMPTE-C is the current color standard for broadcasting in America.
- Native

Camera Log

The Camera Log allows you to enable either the connected camera’s Log (Def. Log) or the user defined log (.cube file generated by CMS software) imported into the TLM-170K.

Def. Log

Rec709 is a color space that produces images that are very normal and realistic with a good amount of contrast and saturation. Log footage recorded on cameras is normally colorless so in order to color grade your Log footage with the Rec709 color space, you can select the appropriate LUT from the list below.

SLog2ToLC-709	Sony Log format to Rec709
SLog2ToLC-709TA	
SLog2ToSLog2-709	
SLog2ToCine+709	
SLog3ToLC-709	
SLog3ToLC-709TA	
SLog3ToSLog2-709	
SLog3ToCine+709	
ArriLogCTo709	Arri Log format to Rec709
ArriLogCToP3DCI	
ClogTo709	Canon Log format to Rec709
VLogToV709	Panasonic Log (Varicam) format to Rec709
JLog To709HLG	JVC Log format to Rec709
JLog To709PQ	
Z7 NLogTo709	Nikon Log format to Rec709
D780 NLogTo709	

User Log

Save color calibration data generated using Light Illusion’s CMS software in .cube files.

Note: Filming with log allows you to view various color grading generated using different logs on the monitor.

Gamma

This sets the gamma correction for the source of input; the smaller the gamma, the brighter the screen and vice versa.

- OFF
- 1.8 (MAC OS)
- 2.0
- 2.2 (Windows)
- 2.35
- 2.4
- 2.6
- 2.8

Notes:

Gamma2.2 is used widely for various applications, providing highlight and shadow enhancement or defining a midtone.

Gamma2.4 is recommended for high quality TV program production and REC709 color space.

Gamma2.6 is the gamma standard for Digital Cinema Initiative (DCI) and movie filming.

HDR

HDR is a new TV video standard that generates higher contrast and wide-gamut images and therefore, an HDR monitor is capable of displaying more colors and details of an image than the regular ones. The TLM-170K offers two HDR transfer functions listed as follows:

- ST 2084 or Perceptual Quantizer is able to represent luminance levels of 300, 1000 and 10000 cd/m².
- HLG stands for Hybrid Log-Gamma which is another HDR transfer function.

Back Light

Adjust the back light level from 0 – 100.

Color Temperature

Select a color temperature for your scene. Color temperatures available on the TLM-170K are listed as follows:

- 3200°K
- 5500°K (Desktop publishing or printing)
- 6500°K (Usually for ordinary PC use)
- 7500°K
- 9300°K (TV pictures)
- User Color

Note: Selection of the User Color mode allows you to manually set the color temperature by adjusting the Red Gain, Green Gain, Blue Gain, Red Offset, Green Offset and Blue Offset.

Marker

Aspect ratio is a crucial element in video shooting and it is defined as the proportion of the width and height of any image. You can use different aspect ratios in your video. Therefore, in order to know what will be in frame at different aspect ratios, during shooting, you can turn on the TLM-170K's aspect marker (a.k.a. guide frame) so that you can record the entire screen while still knowing where the cut-off will be by putting a mat over it.

Center Marker

The Center Marker, if turned on, will place a crosshair in the middle of the screen.

Center Marker Size

The Center Marker size can be set to small, medium or large.

Aspect Marker

Sets the aspect marker display at the aspect ratio selected from the list below:

- OFF
- 16:9
- 1.85:1
- 2.35:1
- 4:3
- 3:2
- 2.0X
- 2.0X MAG
- Grid
- User



Safety Marker

This sets the safety zone display, which is the standard viewing range of the recorded video.

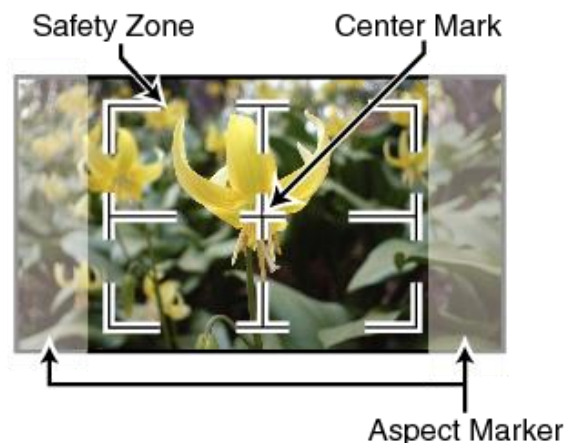

The options are listed as follows:

- OFF
- 95%
- 93%
- 90%
- 88%
- 85%
- 80%

Marker Color

The user is also allowed to apply different colors to the aspect marker. The five available marker colors are **Red**, **Green**, **Blue**, **White** and **Black**.

Aspect MAT

This sets the transparency of the mat placed over the cutoff at the select aspect ratio. Select from 0 to 7 with 7 being an opaque mat and 0 offering the highest transparency.



Thickness

This sets the aspect marker thickness ranging from 1 to 15.

User Marker H1/H2

This adjusts the marker's horizontal position.

Increasing the value moves the marker to the right and decreasing the value moves the marker to the left.

User Marker V1/V2

This adjusts the marker's vertical position.

Increasing the value moves the marker up and decreasing the value moves the marker down.

Function

This allows the user to set advanced settings for the TLM-170K, such as the scan mode, the aspect ratio, underscan mode, H/V delay, check field, zoom, and etc. Details of how these functions can be configured are described as follows:

Scan

This sets the Scan mode of the TLM-170K.

Zoom: Enlarge the original image according to the [zoom ratio](#) of the TLM-170K.

Aspect: Display the image according to the [aspect ratio](#) of the TLM-170K.

Pixel to Pixel: Display the original image resolution without scaling to match a certain resolution or an aspect ratio. For example, when the resolution of the input video is 1920x1080 but the

monitor's resolution is only 1280x800, only area equivalent to 1280x800 out of 1920x1080 will be displayed.

Aspect

The aspect control allows you to manually set the aspect ratio of the monitor. You should choose the aspect ratio of your screen to match that of the input video in order to achieve the best viewing experience. Views of different aspect ratios on the TLM-170K are shown in the diagram below.

Note: Aspect ratio control is disabled if the scan mode is set to pixel to pixel.



full screen



2.35:1



1.85:1



16:9



4:3



3:2

Overscan

If enabled, the image rendered on the display will be larger than the physical area of the screen, creating a cropped image on the monitor screen.

H/V Delay

Used to monitor the blanking area for H sync and V sync.

In **H delay mode**, the horizontal sync is delayed so that the horizontal blanking period is displayed on the screen.

In **V delay mode**, the vertical sync is delayed so that the vertical blanking period is displayed on the screen.

In **H/V delay mode**, both horizontal and vertical syncs are delayed, resulting in both horizontal and vertical blanking periods being shown on the screen.

Note: H/V Delay is disabled if the scan mode is set to pixel to pixel.

Check Field

The check field function offers the user Red-Only, Green-Only, Blue-Only and **Mono** modes for screen calibration should you require them.



First turn on the color bar, then turn on the single color mode in the check field as this allows you to do the screen calibration by adjusting the brightness, contrast, saturation, tint and sharpness.

Zoom

The zoom function allows you to enlarge the image by a certain percentage (10 – 90%).

Note: Zoom control is disabled if the scan mode is set to pixel to pixel.

Freeze

The monitor's screen freezes once enabled.

Waveform

The TLM-170K also allows the user to display the image alongside with different monitoring waveforms such as the waveform, vector scope, histogram and audio level meter.

Image quality can be improved using tools such as peaking filter, false color and zebras.

Waveform

The TLM-170K offers users different waveform options listed as follows:

- Multi (vector scope, YCbCr waveform monitoring, histogram and audio meter)
- Y (Y waveform monitoring)
- YCbCr (YCbCr waveform monitoring)
- RGB (RGB waveform monitoring and histogram)
- Off

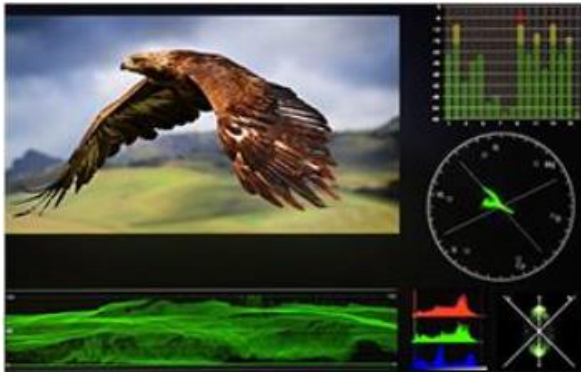

Multi



Y

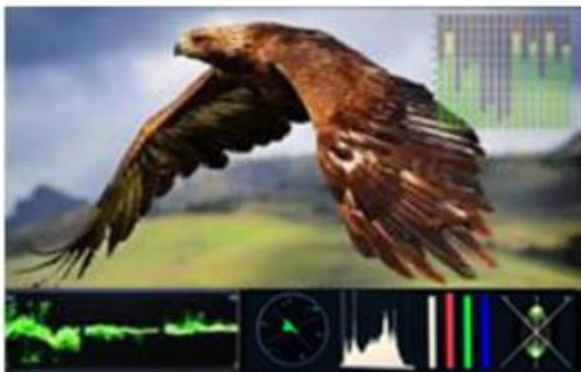

YCbCr

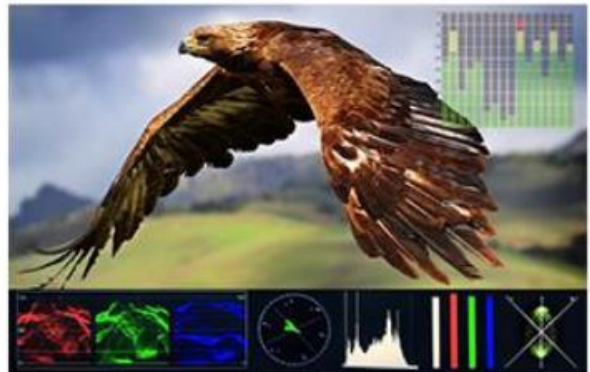

RGB

Note: If **Waveform** is set to **Multi**, the **Histogram** is enabled by default.

Vector Scope



The vector scope is used to measure the color information such as **Hue** and **Saturation** in a video image.

Note: For color bars, the vector scope works with 100% color bars and 75% color bars with a 75% white level.

Hue: The color markers are red, magenta, blue, cyan, green, and yellow. The proximity a signal to one of the markers tells you what color it is.

Saturation: A vectorscope shows you how saturated your color is and how far away the signal is from the center indicates how saturated the color is. For example, if the color

is close to one of those boxes, then that means that color in the image is very saturated.

Intersecting lines: The line going up towards the yellow and red colors is the skin tone line on which the skin color should fall regardless of the person's race.

Waveform Monitoring

Waveform monitoring consists of RGB and YCbCr waveforms which are used to measure the brightness, luminance and chroma of a video signal as shown in the diagram below.

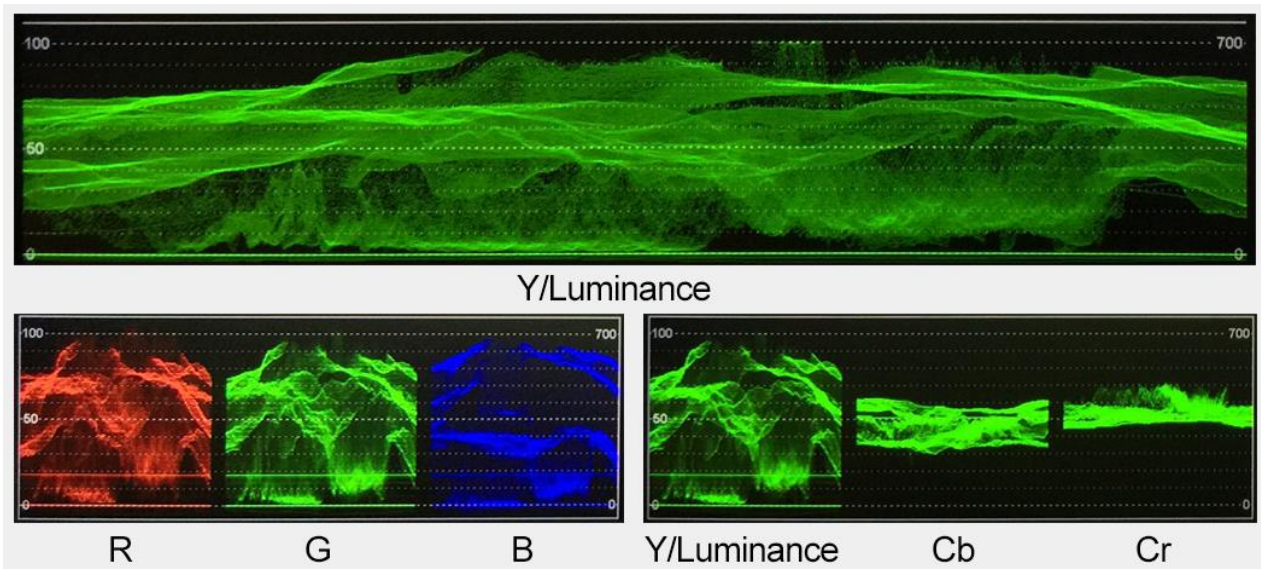

Waveform monitoring not only warns the user of out-of-range conditions such as overexposure but also serves as a good tool for color correction and white and black balance.

Vector

This enables/disables the vector scope.

Transparency

This selects the transparency of the waveform and vector scope.

- 50% blend effect
- 25% blend effect
- Off: Opaque

Peaking filter

The peaking filter, once enabled, will place color lines on edges of the subject of the focus in the image. This function works well if the subject of the focus is correctly exposed for high contrast.

Red, Green, Blue, White and **Black** are the five available outline colors on the TLM-170K.

The **Peaking Level** determines the sensitivity of the filter. Setting the peaking level to a high value means more areas will be highlighted including lower contrast areas. If the peaking level is set to a low value, then only areas of high contrast will be highlighted.

The diagram below illustrates images with peaking filter applied to the subject of the focus. Note the different colors of the outline in each picture.



False Color

Also known as the exposure assist, once enabled, the false color feature will change colors of the elements of the image based on the brightness value. This allows the user to use the monitor's exposure function to achieve proper exposure without the use of costly external equipment.

To best utilize this feature, you must first understand the color chart below. The color chart is like a color scale. The exposure level is represented by different colors which correspond to the respective luminance of the pixels as displayed on the monitor. The correct exposure ranges from 10 – 100%. Anything below 10% is regarded as underexposed and if exposure exceeds 100%, it is deemed overexposed.

Underexposure and overexposure will lead to loss of details in an image.

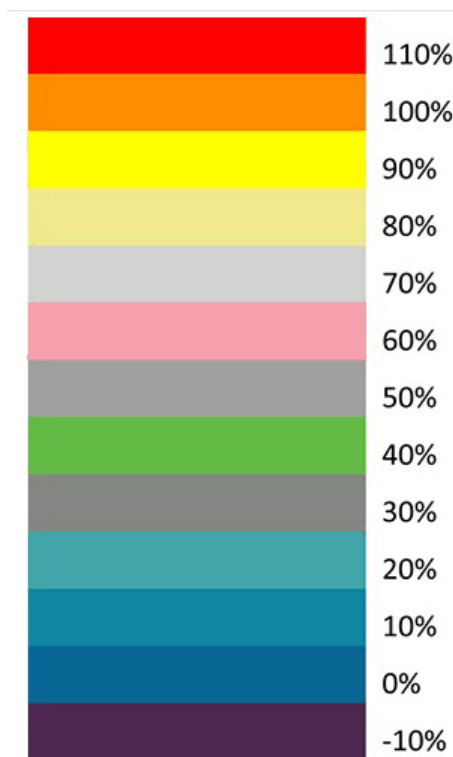

For example, areas with exposure level of 56IRE when applied the false color will be shown as pink color on the monitor. Therefore, as you increase the exposure, that area will change color to grey, then yellow and finally to red if overexposed. Blue indicates underexposure.

An example of an original image with the false color applied is shown on the left of the image below.

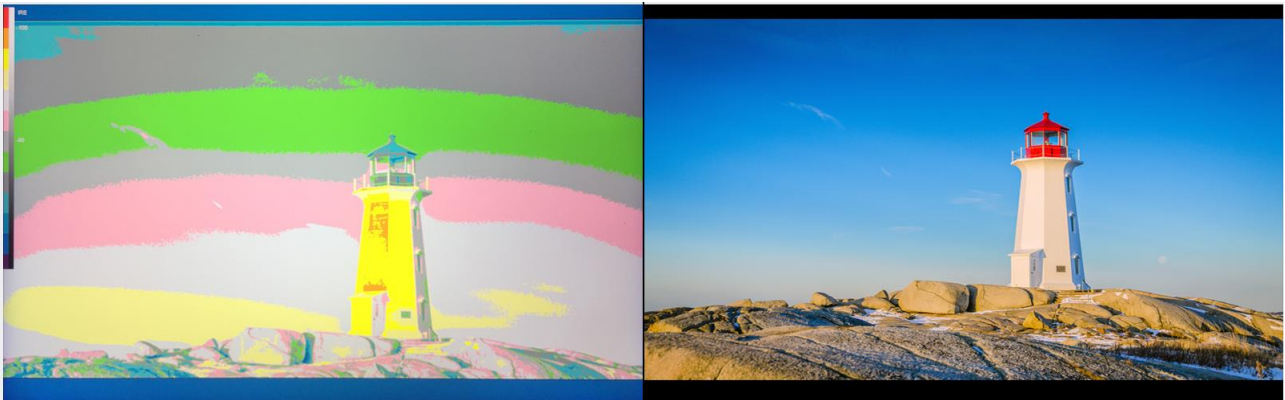

The four available false color modes are **Default (Normal)**, **Spectrum**, **ARRI** and **Red**, which are illustrated in the diagram below.

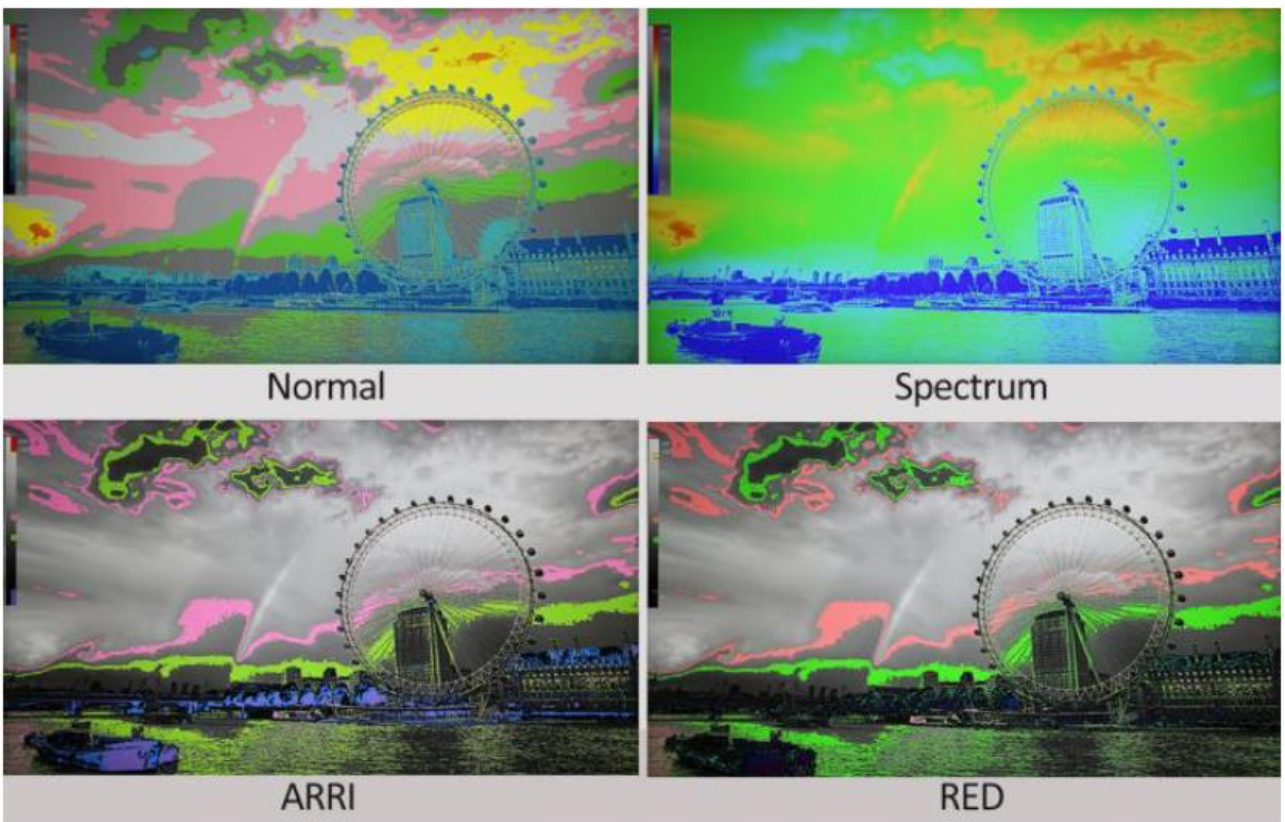

False Color Table

This enables/disables false color chart on the screen. A sample of the chart is shown below.



Exposure

Once the exposure function is turned ON, you will be able to see a zebra pattern superimposed over parts of the image that are exposed to a specific level. In this way, the exposure of the image displayed on the screen can then be adjusted accordingly on the monitor by changing the exposure level (50 – 100 IRE).

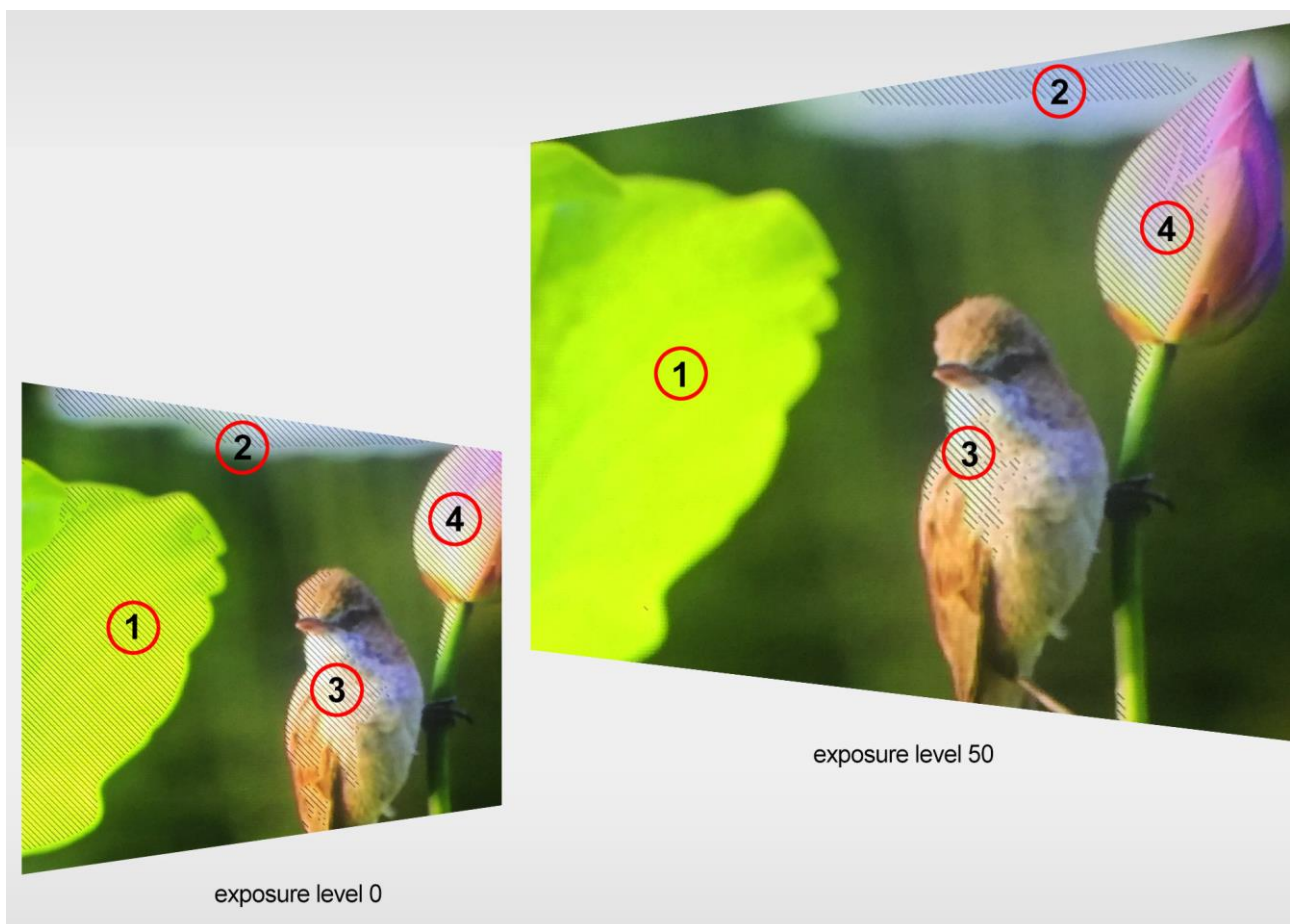

Histogram

The histogram is a great tool that helps you to improve the overall exposure of the image.

Y (Luminosity)

The Y or luminosity histogram is a graph that describes the human-eye perceived brightness distribution within an image.

To produce the luminosity histogram, first break an image into individual pixels, then each pixel is converted so that it becomes a luminosity based on a weighted average of the three colors at that pixel. The green, red, and blue channels account for 59%, 30% and 11% of the perceived luminosity respectively. This is because human eye is more sensitive to green light than it is to blue or red light. Finally the luminosity histogram is produced by counting how many pixels are at each brightness level as shown in the diagram below.

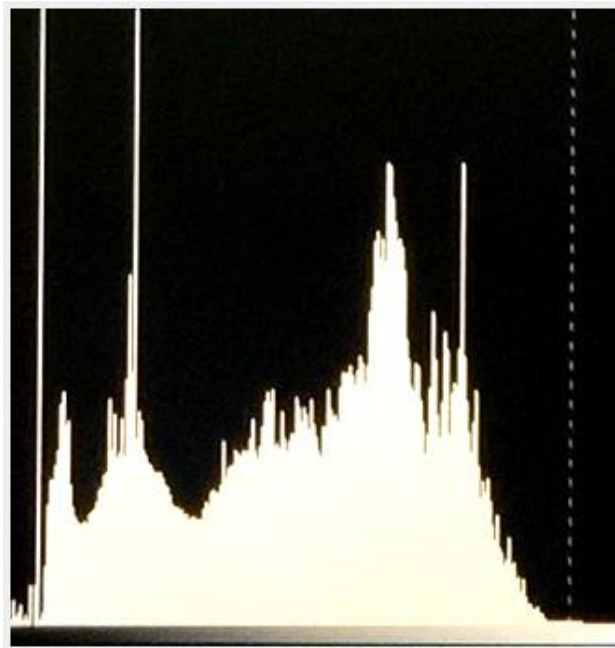

RGB

The RGB histogram is a graph that represents the overall brightness of the entire image.

In any digital image, each individual color is made by combining red, green and blue lights with each light represented by its brightness level ranging from 0 to 255. Therefore every color produced in this way has a specific brightness value based on mixes of red, green and blue throughout the image and these brightness values of all the different colors in an image are represented in a histogram which is known as the RGB histogram.

On the TLM-170K, the RGB histogram is shown with the color overlay as depicted in the diagram below.

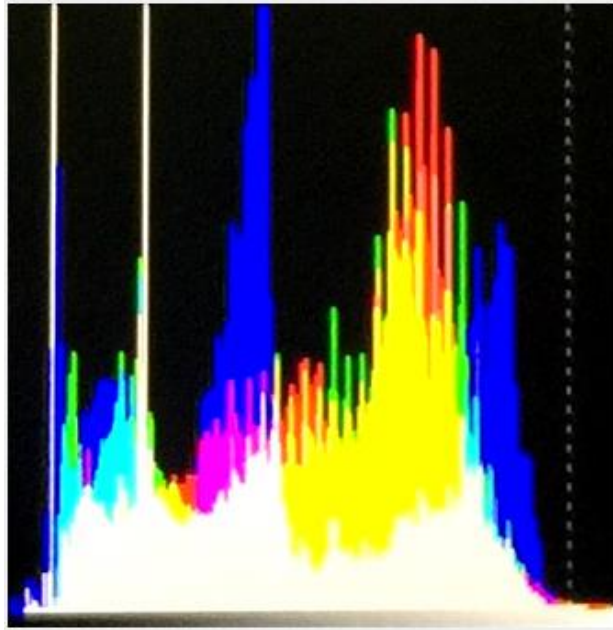

Color

By setting the histogram to color, you will see one red histogram, one green histogram and one blue histogram. Each color histogram is basically a representation of how that color's intensity is distributed throughout an image, allowing you to evaluate the brightness and exposure of that individual color channel. See the diagram below for an example of the color histogram.

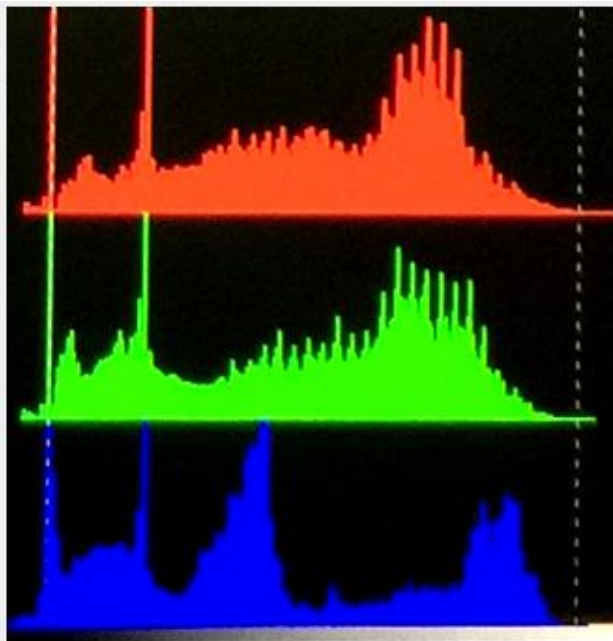

Time Code

The TLM-170K is able to decode the following SMPTE timecode formats:

- **LTC:** Linear timecode.
- **VITC:** Vertical interval timecode.

The decoded time code will be shown at the top of the screen.

Note: Time code is only available with the SDI input.

Audio

Volume and Level Meter

The Volume option sets the audio level of the input video, which can be viewed visually on the TLM-170K by enabling the **Embedded Audio Level Meter**.

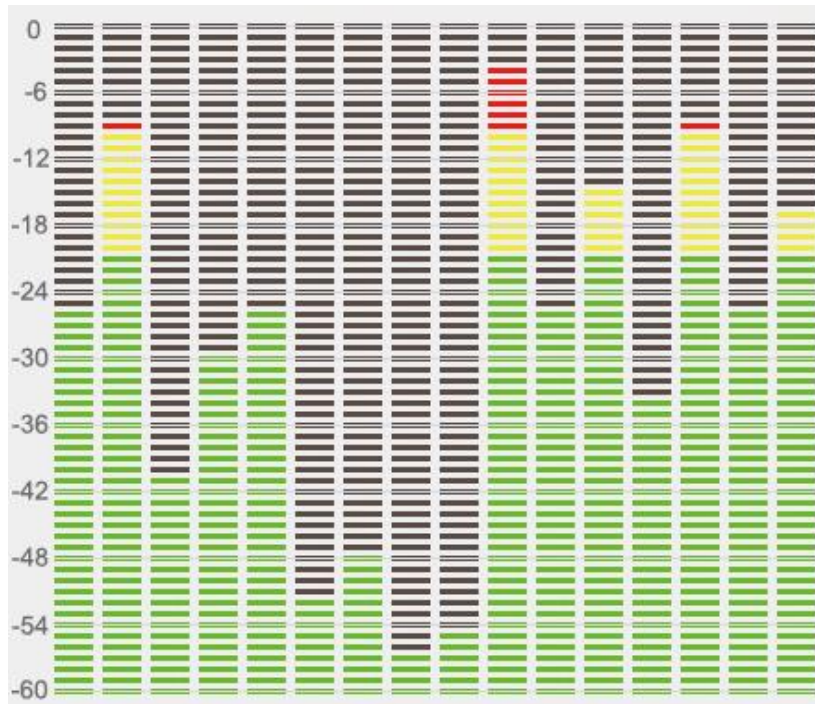

Note: If the monitor is in SDI mode, you will see 16 SDI embedded audio channels; in HDMI mode, there will be 8 HDMI embedded audio channels.

Audio Vector

Enable the audio vector scope shown below to view the audio information.

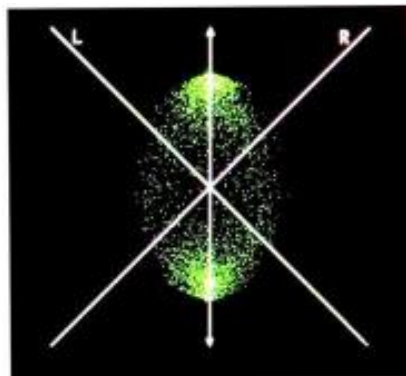

Audio Vector CH (HDMI)

First enable the audio vector scope, then select an audio input channel pair to view the audio information.

Audio Vector CH (SDI)

First enable the audio vector scope, then select an audio input channel pair to view the audio information.

Audio Left Out

Assign an audio channel to the left audio output channel.

An SDI input supports up to 16 embedded audio channels and an HDMI input supports 8 embedded audio channels.

Audio Right Out

Assign an audio channel to the right audio output channel.

An SDI input supports up to 16 embedded audio channels and an HDMI input supports 8 embedded audio channels.

System

In the System sub menu, you will be able to do the following:

1. Change the language of the OSD menu
2. Turn on the color bar
3. Set the OSD ON time
4. Flip the image
5. Select color calibration
6. Switch the standby power mode
7. Reset the entire device's settings

Language

The available languages are **English**, **Traditional Chinese** and **Simplified Chinese**.

Color Bar

Available options are listed as follows:

OFF: disables the color bar

75% or 100% color bar

Color Bar Mode

The TLM-170K offers three color bar modes listed as follows:

- REC601: SD video
- REC709: HD video
- BT2020: 4K or 8K video

OSD Timer

This sets the OSD menu's ON time; the OSD menu will be automatically turned off after the timer times out.

- 10s
- 20s
- 30s

OSD Transparency

This sets the OSD menu transparency. You can set the transparency level to either 25% or 50%. Disabling this option will yield an opaque OSD menu.

OSD H Position

This adjusts the horizontal screen position of the OSD menu.

OSD V Position

This adjusts the vertical screen position of the OSD menu.

Fan

This allows you to turn **ON/OFF** the monitor's built-in fan. If you set this option to **Auto**, the fan will be turned ON if the monitor is overheated.

Color Calibration

To use this feature, you will need to purchase Light Illusion's LightSpace Color Management System (CMS) which includes a calibration probe and the CMS software. The TLM-170K works with CAL, PRO and XPT versions only. Visit <https://www.lightillusion.com/lightspace.html> for more information.

See the **CMS Color Calibration Process** in the subsequent chapter.

Comparison EN

By enabling this option, you will be able to see the difference between the original image and the image with the selected color setting applied as illustrated in the diagram below.



Gamma	HDR
Original	Color Space
Original	Camera Log

Reset

Select **ON** to reset the device entirely.

5. Color Management System – Calibration Process

This chapter will discuss the use of Light Illusion's CMS software for color correction.

Device Setup

1. Before starting the calibration process, you need to install and register the CMS software first. Copy and paste the link <https://www.lightillusion.com/colourspace.html> into your browser's address bar then hit enter to open the ColourSpace page shown below.

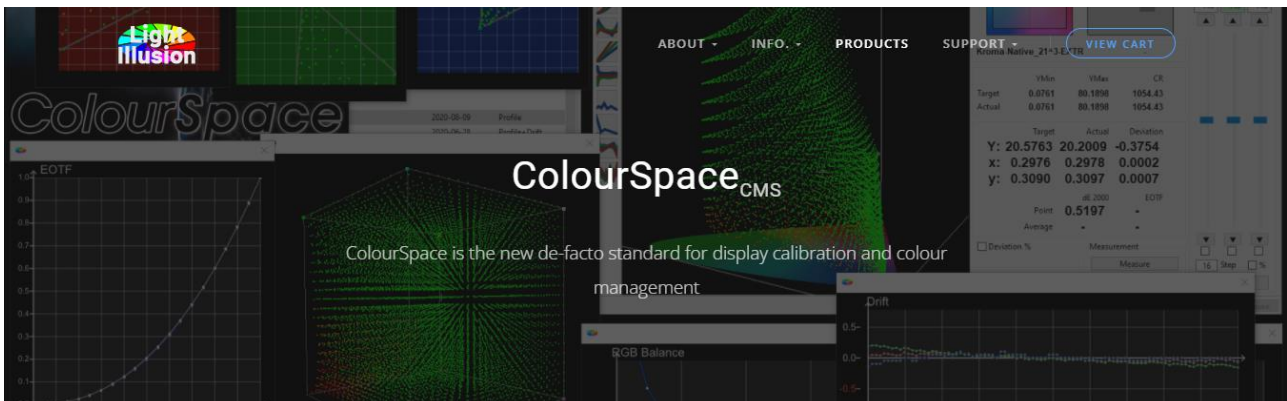

Building on the unmatched capabilities of Light Illusion's previous calibration system, ColourSpace is a ground-up, and totally new product development that far exceeds the capabilities of any previous or present alternative calibration system.

Latest ColourSpace Release: 11th December v1.0.0.1312

(Latest ZRO Release: 11th December v1.0.0.1312)

- ✓ Unmatched Calibration Accuracy
- ✓ Volumetric 3D graphs
- ✓ Post & Broadcast
- ✓ Medical
- ✓ Pro. AV
- ✓ Home Cinema
- ✓ Display Manufacturers
- ✓ Free Updates
- ✗ Yearly Maintenance Fee

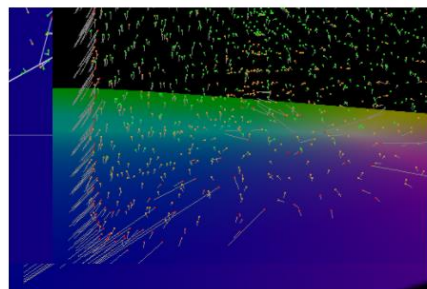

? ColourSpace Options -

Professional Calibration

ADD TO CART

ColourSpace LTE - £625

Ex. VAT

To discuss package deals, multiple license discounts, and alternate payment methods please use the [Quote form](#)

Unlike alternative calibration systems, ColourSpace licenses are valid for the life of the product (except for Rental licenses), with no expiry, no annual maintenance fee, and include free [Software Updates](#) for the purchased license options for the life of the product.



Note: There are different versions of the CMS software. Make sure you download the right version for your calibration device, for example, the LTE version is for Datacolor Spyder4/5, Eizo Internal, i1 Display Pro OEM, i1 Display 1/2/LT and i1 Pro 1/2. You will need higher versions for Minolta CA-310 and Klein series.

Click the link https://www.lightillusion.com/i1display_pro.html to purchase i1Display Pro OEM colourimeter.

Click the link https://www.lightillusion.com/murideo_six-g.html to purchase 4K & 8K signal generator. Please note that the signal generator is optional.

2. Connect the calibration device to the PC or the laptop then the TLM-170K monitor via the HDMI interface. Enable Extended Desktop Mode on the PC or the laptop. Finally, open your graphics control panel to set the HDMI output to Full Range. The Intel HD Graphics Control Panel is shown in the diagram below for illustrative purposes.

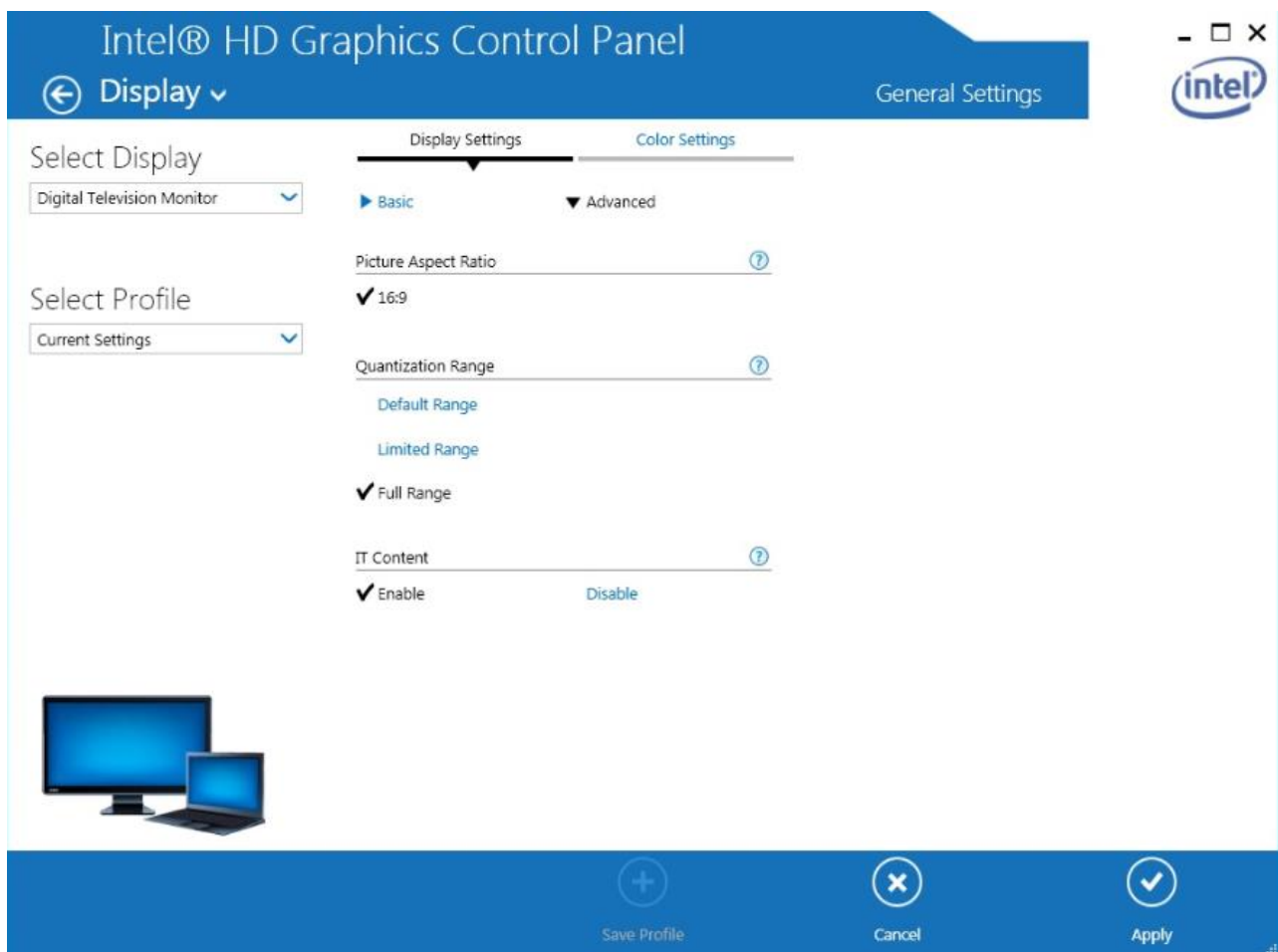

3. After you've successfully installed the CMS software, double click the icon below to open the software.

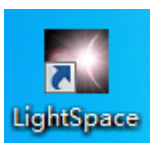

The CMS software interface is shown below.

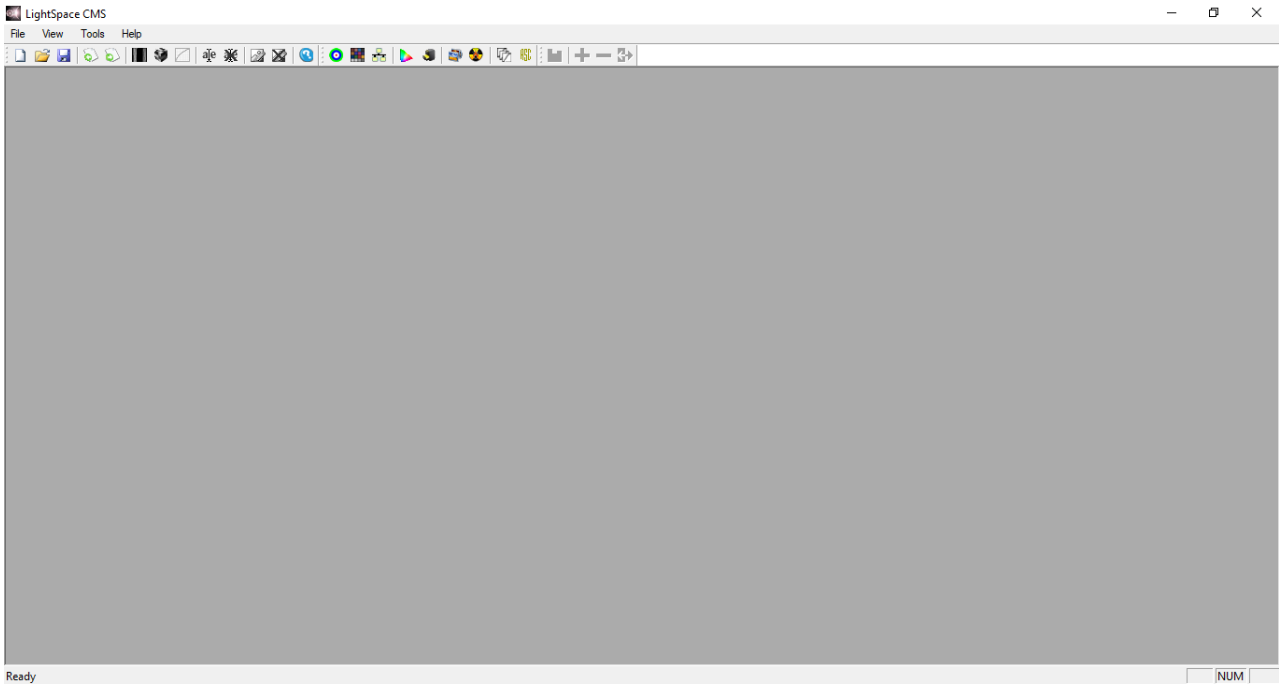

Please note that the monitor must be warmed up before calibration. Turn ON the monitor and the color calibration device and leave them running for about 30 minutes. You can start color calibrating your monitor after you've completed the device setup.

Software Setup

1. Select the connected "Probe"

Follow the path "**Tools** → **Discoverable Probes**" to access the color calibration devices supported by the CMS. Select the color calibration device that is connected to the PC or the laptop. The software setup guide will use i1Display Pro OEM for illustrative purposes.

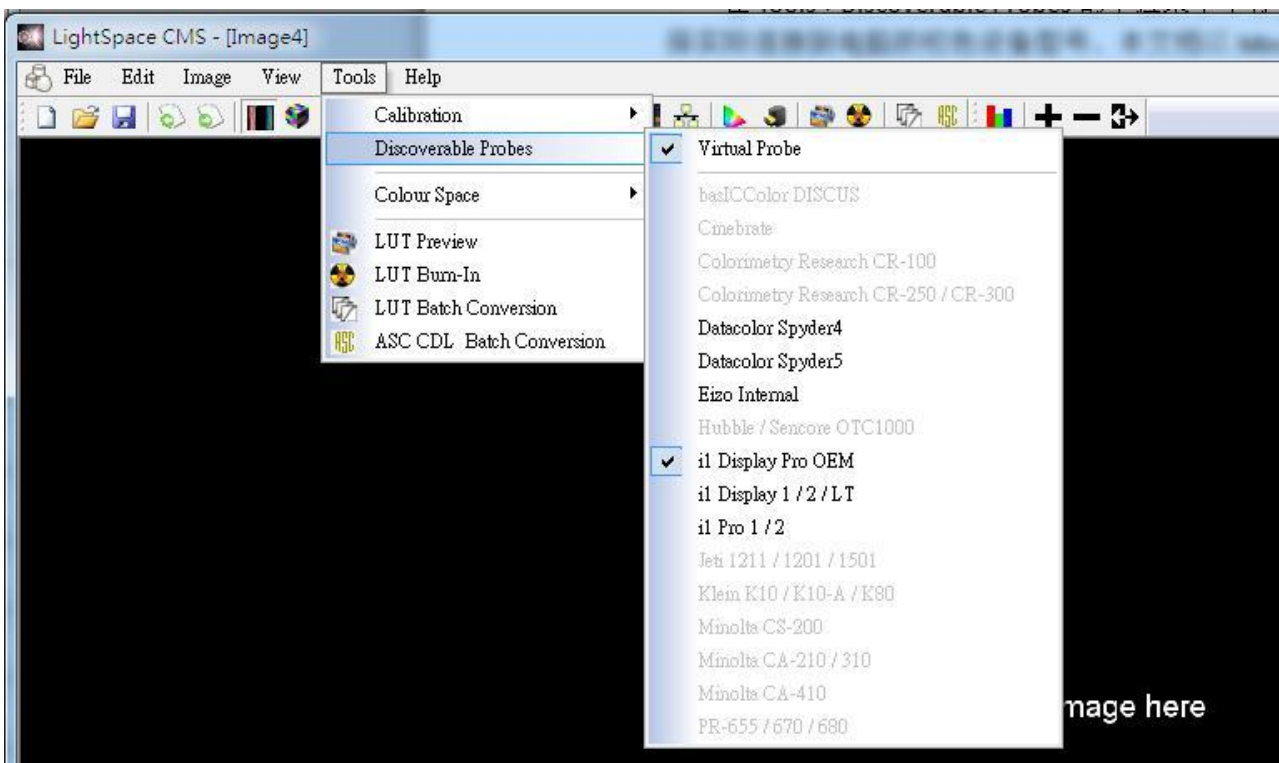

2. Establish communication with the “Probe”

Because the CMS software does not establish connection with the color calibration device automatically, you will need to manually establish communication between the Probe and the PC.

Select “**Tools → Calibration → Calibration Interface or Display Characterization**”

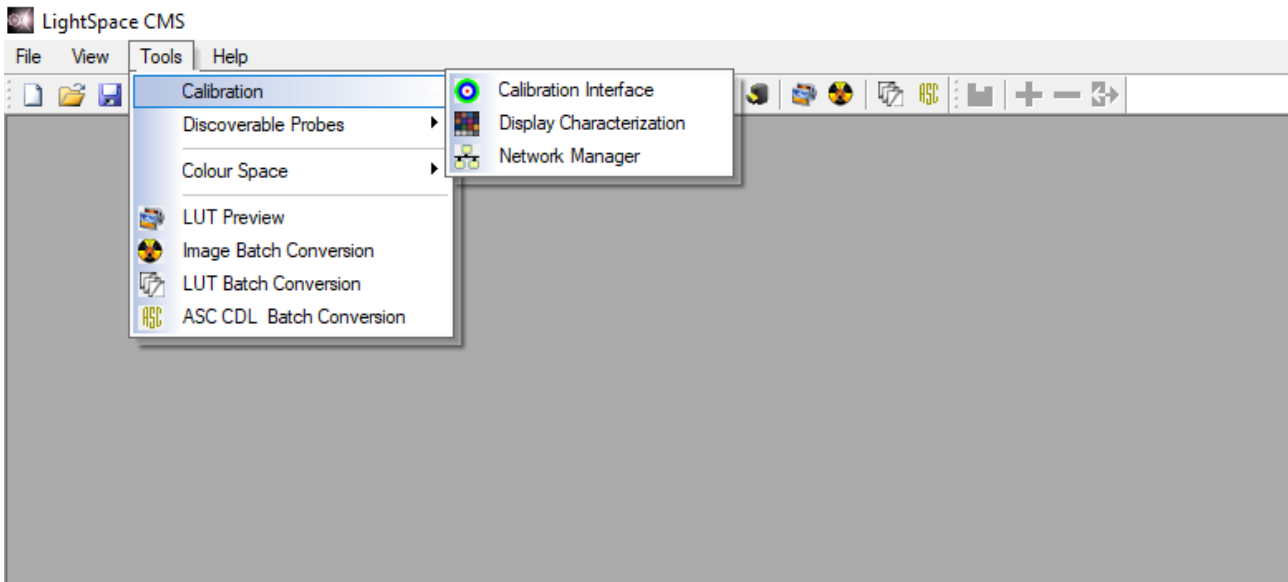

The CMS should detect the probe and a dialogue box with the message “Do you want to connect to i1 Display Pro” should pop up.

Note: If the probe model is CA-310, you should see the corresponding model number in the message.

Click “**OK**” if the detected color calibration device is correct.

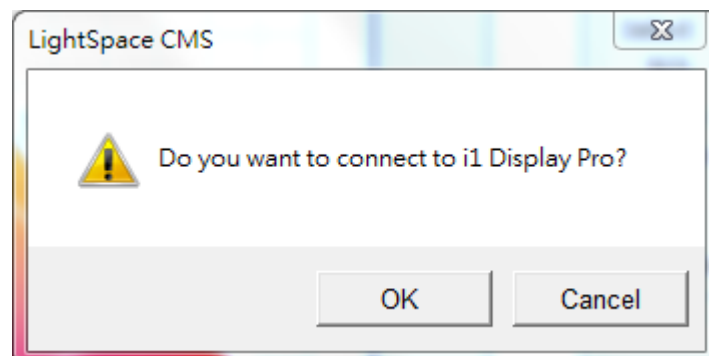

3. Warm up the monitor before calibration.

Make sure the monitor and the color calibration device are turned ON and leave them running for about 30 minutes.

4. Enable the TLM-170K monitor’s color calibration mode.

Open the TLM-170K’s OSD menu, then select **System → Color Calibration → ON**.

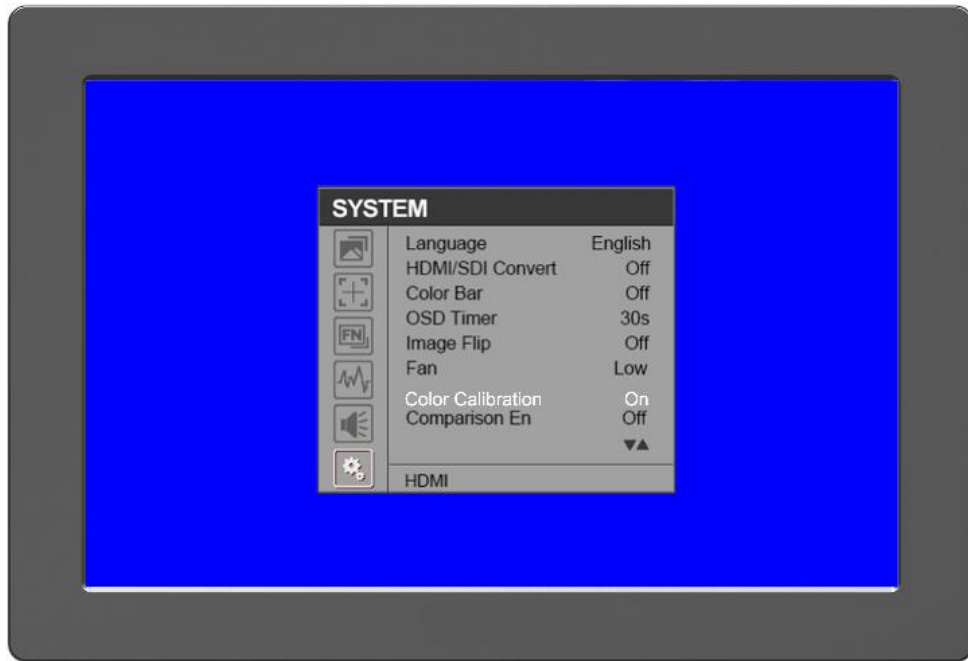

5. Luminance calibration (adjust the backlight).

On the CMS User Interface, click **Tools** → **Calibration** → **Calibration Interface** to open the **Calibration Interface** window then click the **Options** button to open the window below.

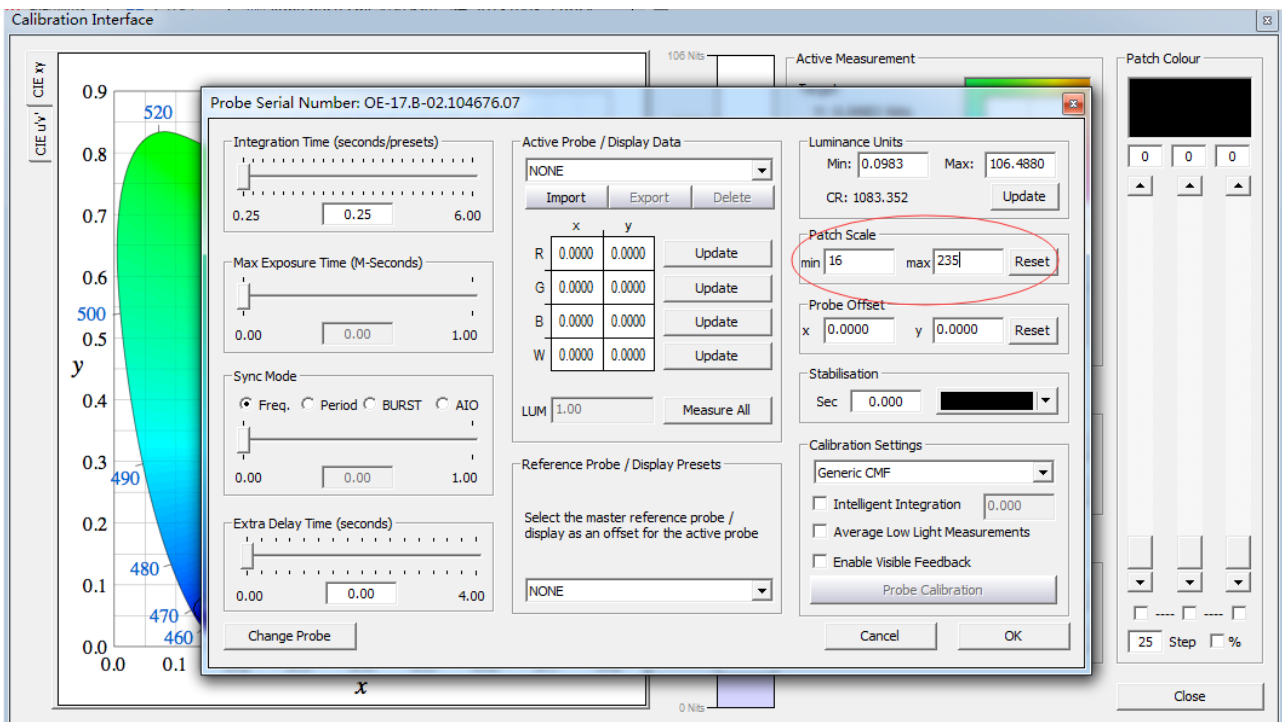

Locate Patch Scale pane (circled in red in the diagram above), then enter 16 in min and 235 in max.



Open the TLM-170K's OSD menu to adjust the monitor's backlight value and click the **Update** button in the **Luminance Units** pane located at the top right of the window above.

As soon as the **Update** button is clicked, the **Calibration Status** window will appear along with the **Calibration Area** and a dialogue box. Drag the **Calibration Area** to the TLM-170K. Lastly, point the probe at the calibration area as close as possible then click the **OK** button in the dialogue box to start calibration.

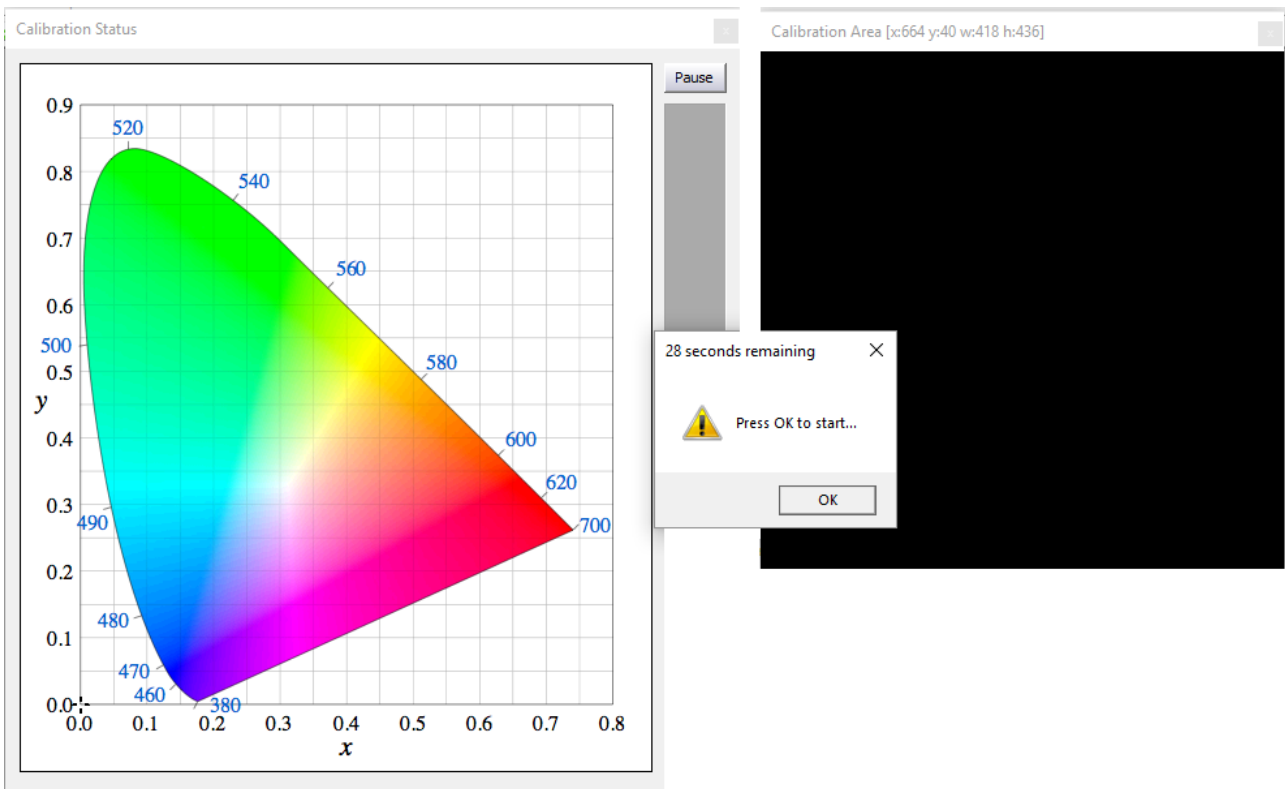

Repeat the process until the **MAX** value in the **Luminance Units** pane is in the range of 80 – 120. **Note that the closer the MAX value to 100, the better the TLM-170K is calibrated.**

6. Color calibration

On the Display Characterization window (**Tools** → **Calibration** → **Display Characterization**), slide the **Select Cube Side** slider to 21 so that the Total Frames measured are 9261. Set **Patch Sequence** to **Sequential** and **Select Time per Frame** to **Closed Loop Mode**.

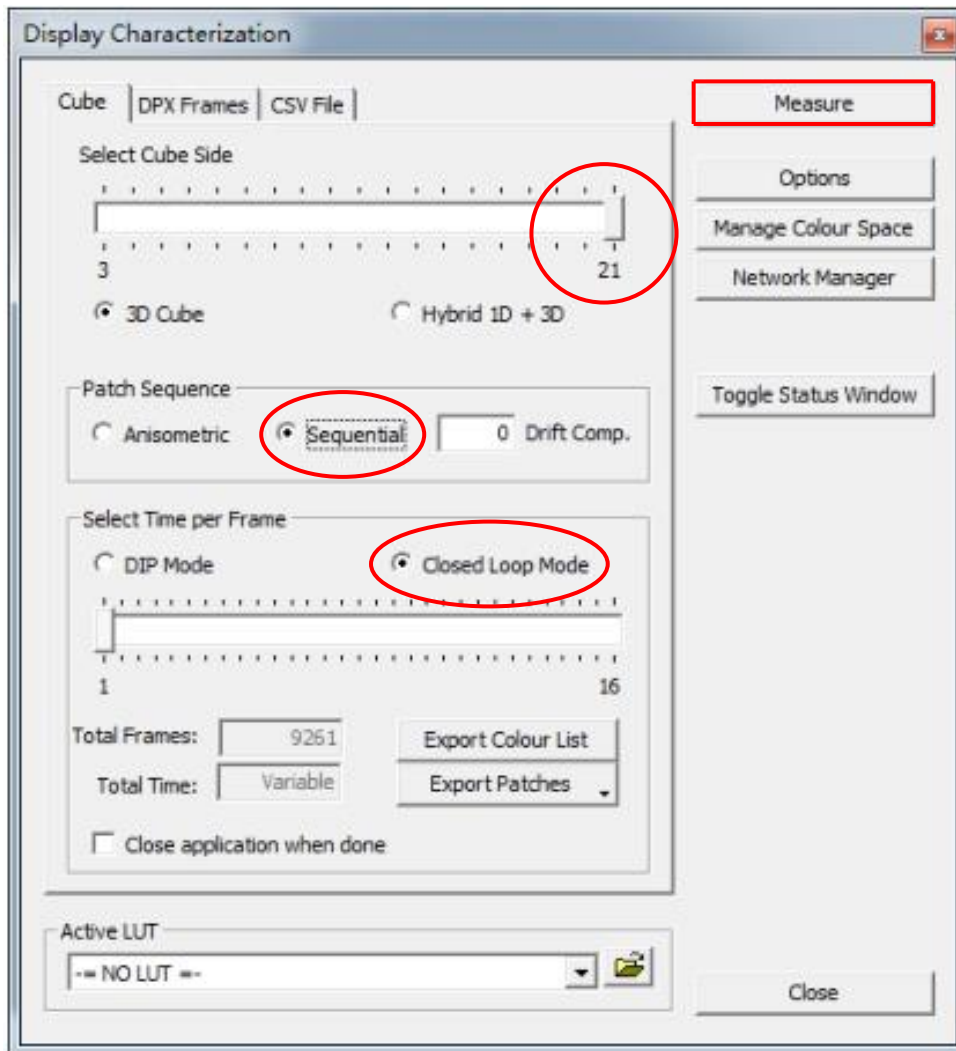

Click the **Measure** button, the **Calibration Status** window will appear along with the **Calibration Area** and a dialogue box. Drag the **Calibration Area** onto the TLM-170K. Lastly, enter a name for this particular calibration in the dialogue box, point the probe at the calibration area as close as possible then click the **OK** button to start calibration. **Please note that it takes approximately one hour to perform 9261 point measurements.**

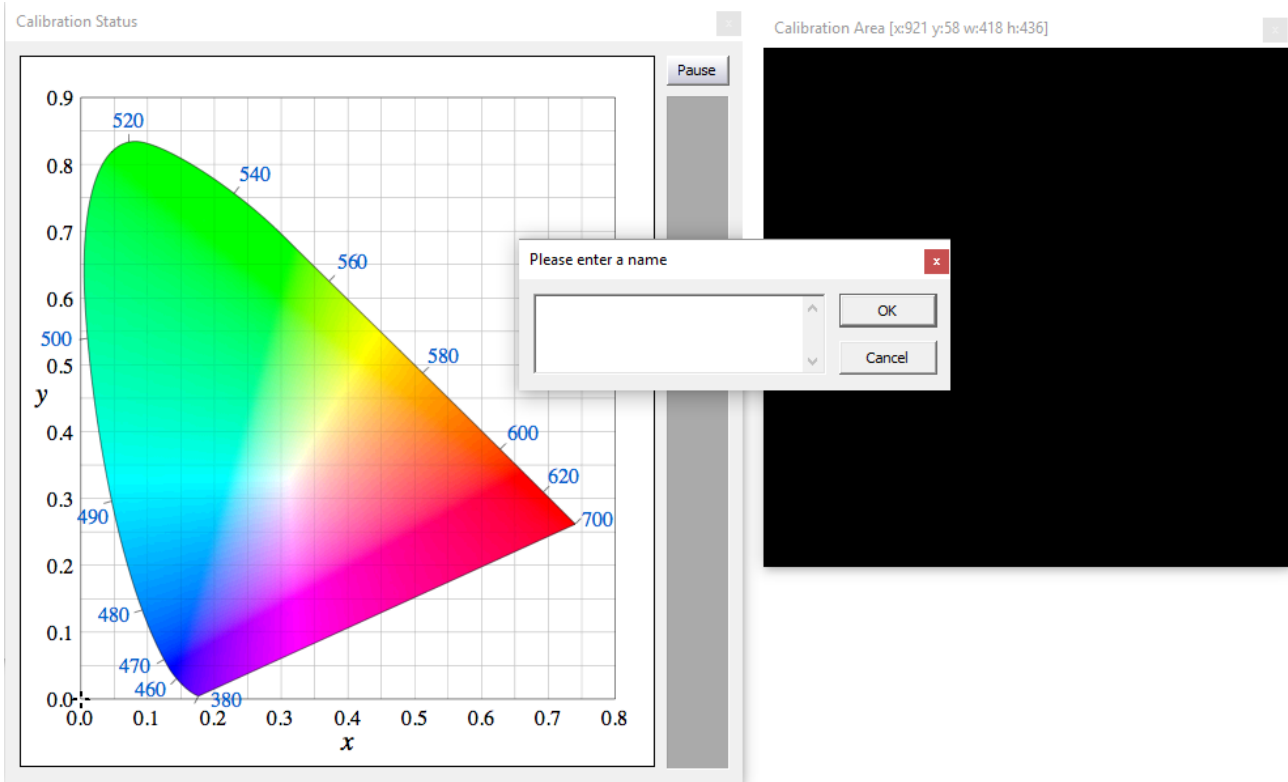

7. Create a 3D Cube Color Calibration File

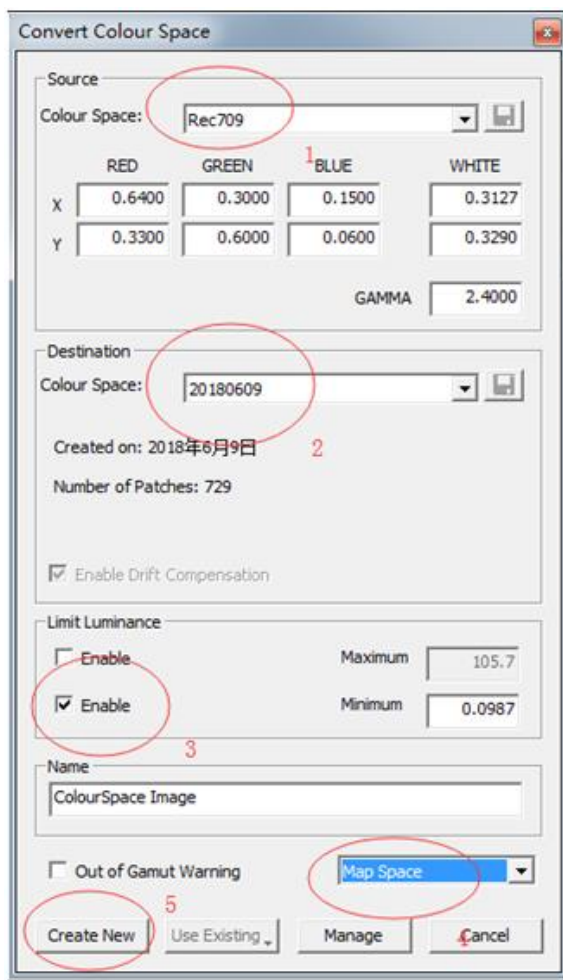

Click **Tools** → **Colour Space** → **Convert Colour Space** to open the **Convert Colour Space** window. In the **Source** pane, select **Rec709** for the color space and in the **Destination** pane, select the color space generated in the previous step.

In the **Name** textbox, enter the name of the 3D cube color calibration file. The rest of the settings should be configured as shown in the diagram on the left. Click **Create New** button to generate the color conversion data.

Now click **File → Export** then select the **“[3D] DaVinciResolve33 (*.cube)”** format. Lastly click the Export button to export the 3D Cube file to a USB thumb drive.

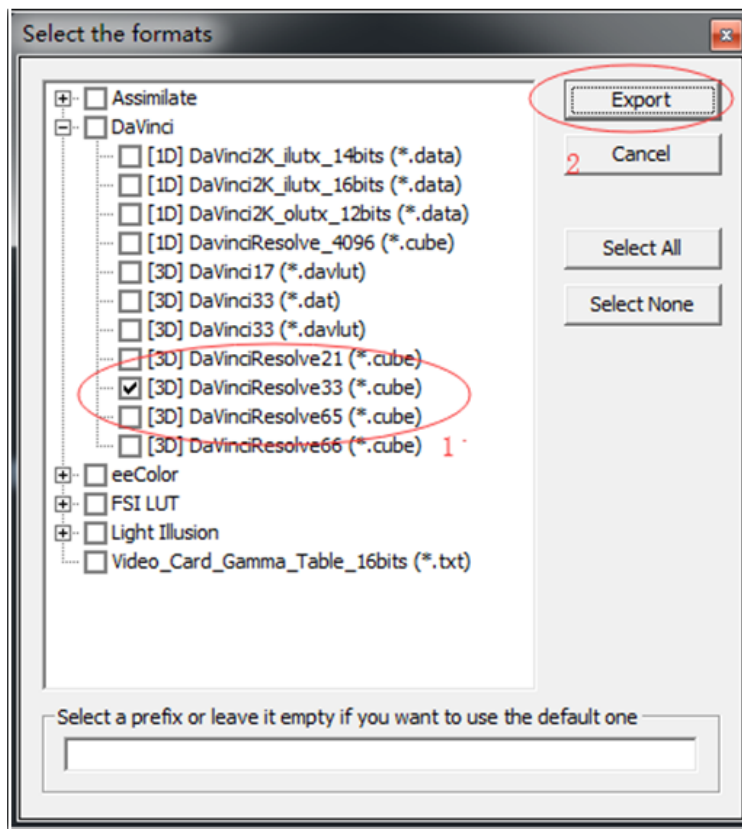

Settings and file exports of the DCI-P3 and BT2020 color spaces are depicted in the diagrams below.

DCI-P3

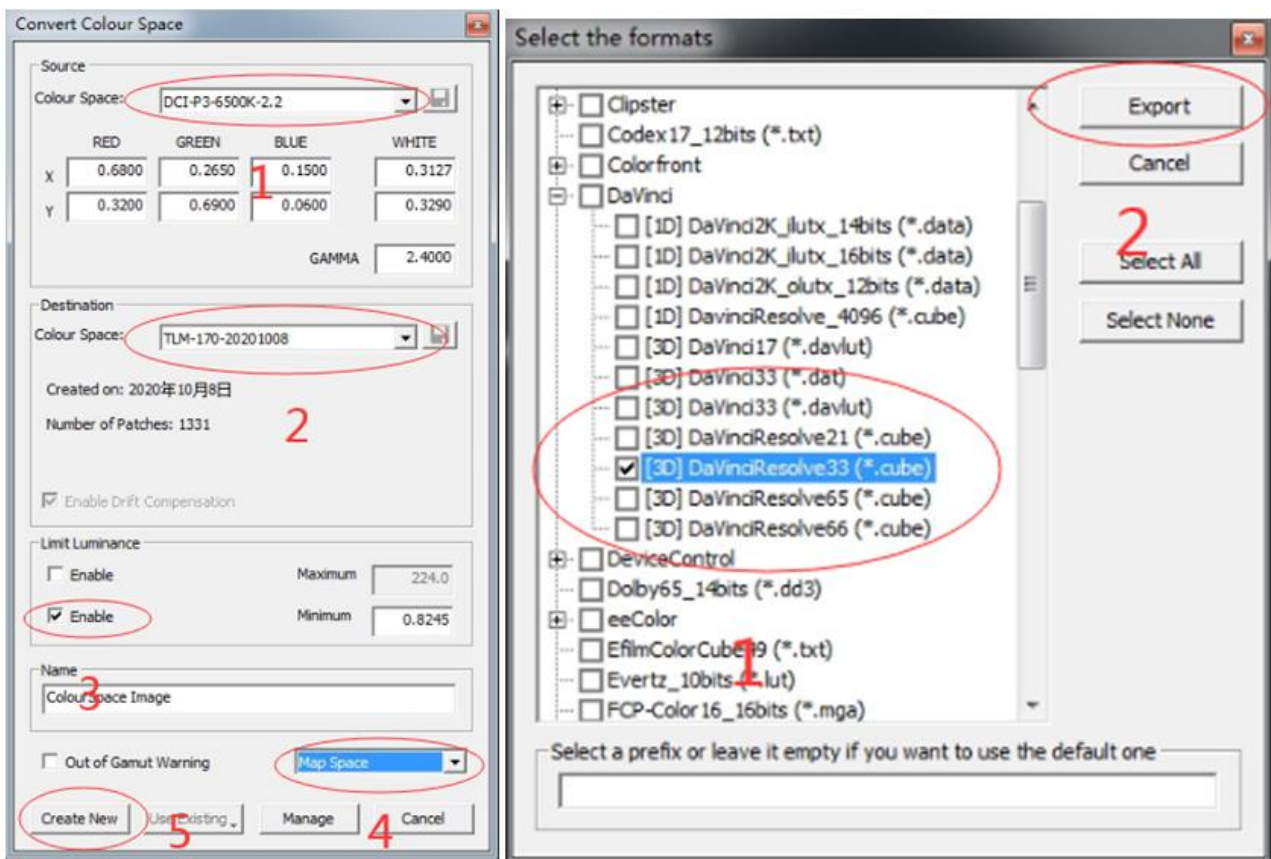

BT-2020

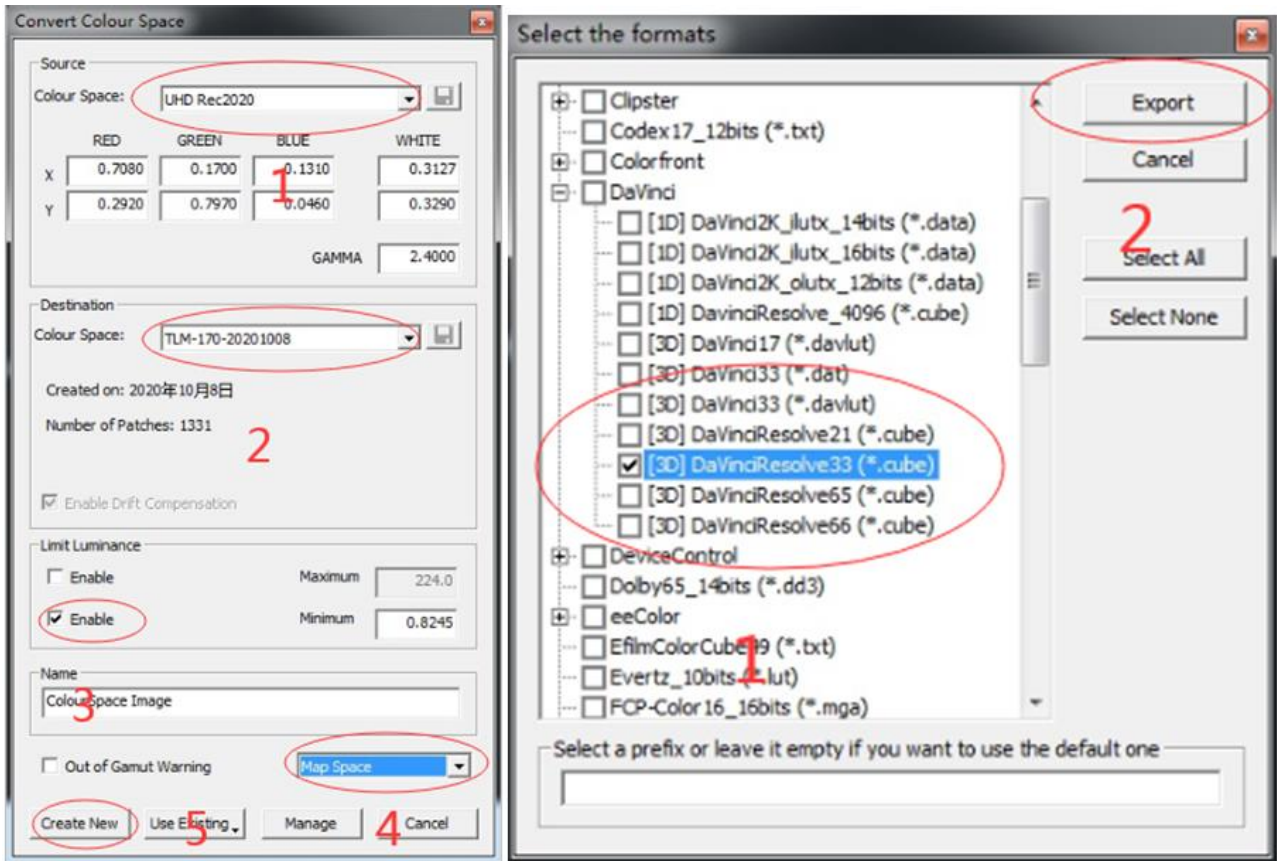

8. Import the 3D Cube file to the monitor

Rename the three exported 3D cube files (REC709, DCI-P3 and BT2020) to **“User1.cube”**, **“User2.cube”** and **“User3.cube”** respectively and save them on a USB thumb drive. Insert the USB thumb into the **SERVICE** port of the TLM-170K and you will be prompted whether to write the 3D CUBE file to the monitor. Select **“Yes”** to write the 3D Cube file to the monitor. The color calibration process is complete after the 3D CUBE file has been written to the monitor successfully.

Lastly, open the TLM-170K’s OSD menu, select **“PICTURE”** → **“User Log”** then select the 3D CUBE file imported previously.

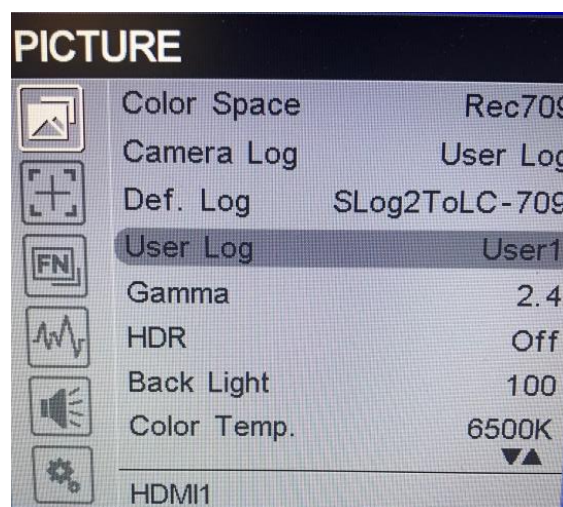

6. Firmware Update

Datavideo usually releases new firmware containing new features or reported bug fixes from time to time. Customers can either download the TLM-170K firmware as they wish or contact their local dealer or reseller for assistance.

This section outlines the firmware upgrade process which should take ***approximately 20 minutes to complete***.

The existing TLM-170K settings should persist through the *firmware upgrade process, which should not be interrupted once started* as this could result in a non-responsive unit.

Successful firmware upgrade on TLM-170K requires:

- Latest TLM-170K firmware version
- USB 2.0 Portable Drive (Max. 16GB)
- USB A Cable

To update the TLM-170K firmware

MCU

1. Unzip / extract the firmware file.
2. Rename the bin file to “mcu.bin”.
3. Format the USB 2.0 pen drive to FAT32.
4. Copy mcu.bin to the USB 2.0 pen drive.
5. Power off the TLM-170K (On/Off Switch at the back of the monitor)
6. At the back of the monitor, plug the USB 2.0 pen drive into the USB 2.0 port labelled **SERVICE**.
7. Power ON the TLM-170K while pushing down the EXIT key.
8. Release the EXIT key when the F1 button LED starts flashing (the firmware is being updated). The TLM-170K should reboot automatically after the update is complete.
9. To check the firmware versions, push down the EXIT key for 3 seconds then release; push down the MENU key for another 3 seconds then release; push down the EXIT key for another 3 seconds again to show the firmware versions on the OSD menu.



FPGA

1. Unzip / extract the firmware file.
2. Delete the contents of the USB 2.0 pen drive so it is empty.
3. Copy the fpga.bit to the USB 2.0 pen drive.
4. Plug the USB 2.0 pen drive into the USB 2.0 port labelled **SERVICE** on the back of the monitor.
5. "Load FPGA..." appears on the screen as soon as the **TLM-170K** detects the fpga.bit file.
6. fpga.bit is automatically loaded on the **TLM-170K**.
7. The **TLM-170K** reboots itself after fpga.bit is successfully loaded.
8. The firmware update is complete if the **TLM-170K Monitor reboots successfully**.

7. Dimensions

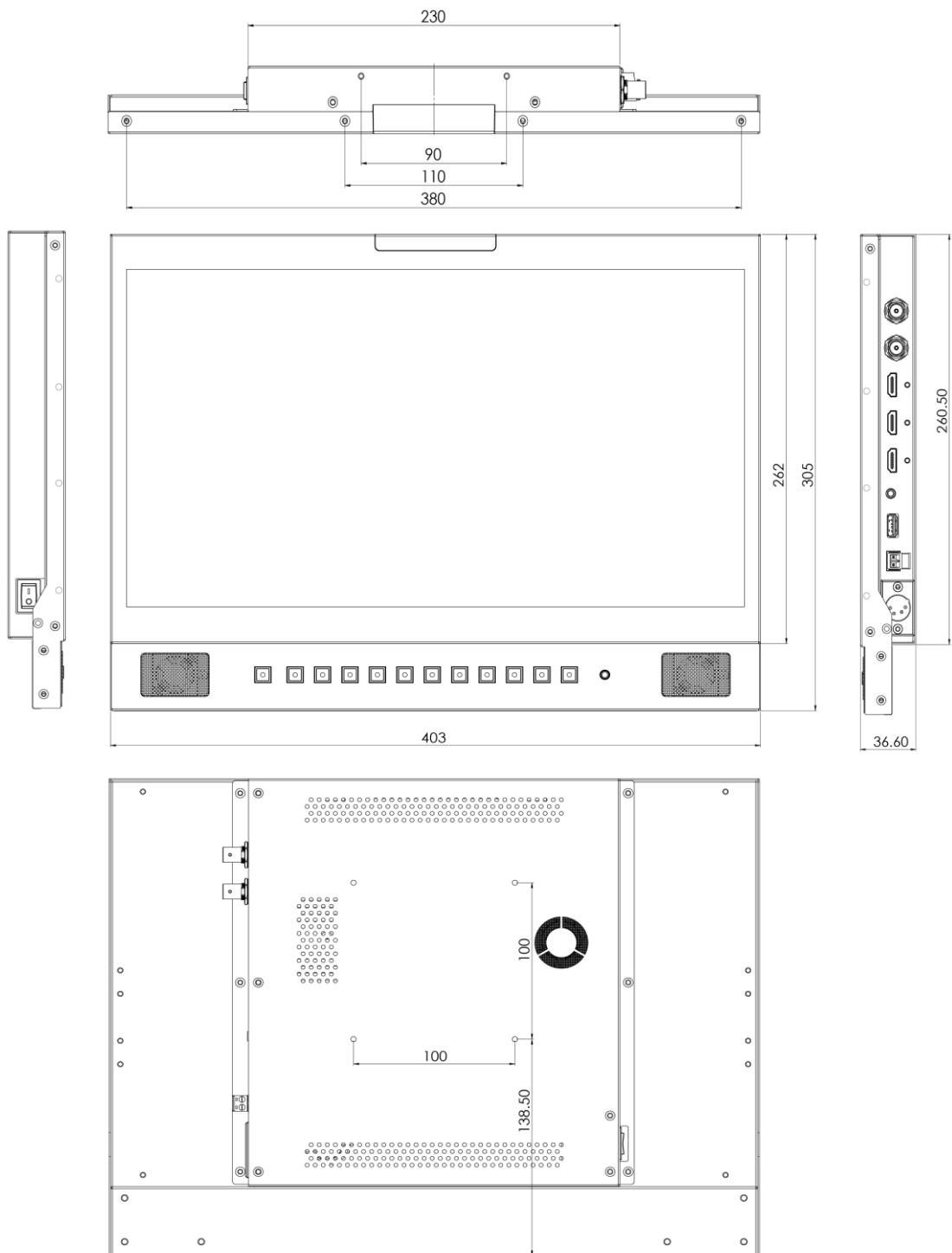

All measurements in millimeters (mm)

8. Specifications

LCD Display	
Size	17.3 inch
Resolution	3840 × 2160
Pixel Pitch	0.0995 x 0.0995
Brightness	300 cd/m ²
Contrast Ratio	1000 : 1
View Angle (Typ.)	178°(H) / 178°(V)
Interface	
Video Inputs	1 x 12G SDI, 1 x HDMI (2.0)
Video Loop Through OUT	1 x 12G SDI, 1 x HDMI (2.0)
Audio Inputs	Embedded Audio (48KHz sampling)
Audio Outputs	Analog stereo (Phone Jack) Speaker x 2 (3W)
Tally	1 x Tally port
Firmware Update	USB 2.0
Power In (12V)	1 x XLR 1 x Phoenix terminal (Pitch 5.08mm)
Standard	
SDI Signal Format	4096x2160p (23.98/24/25/29.97/30/50/59.94/60) 3840x2160p (23.98/24/25/29.97/30/50/59.94/60) 4096x2160Psf (23.98/24/25/29.97/30) 3840x2160Psf (23.98/24/25/29.97/30) 1920x1080p (23.98/24/25/29.97/30/50/59.94/60) 1920x1080i (50/59.94/60) 1920x1080Psf (23.98/24/25/29.97/30) 1280x720p (23.98/24/25/29.97/30/50/59.94/60) 525i, 625i
HDMI Signal Format	4096x2160p (23.98/24/25/29.97/30/50/59.94/60) 3840x2160p (23.98/24/25/29.97/30/50/59.94/60) 1920x1080p (23.98/24/25/29.97/30/50/59.94/60) 1920x1080i (50/59.94/60) 1280x720p (23.98/24/25/29.97/30/50/59.94/60) 720 x480i (NTSC), 720 x576i (PAL) 640 x800, 800 x600, 1024 x768, 1280 x800

General	
Power	12V/40.1W (12V/5A)
Operating Temperature	0°C to 40°C (32°F to 104°F)
Storage Temperature	-20°C to 60°C (-4°F to 140°F)
Humidity	10% to 80% (non-condensing)
Dimension (mm)	403(L) × 305(W) × 36.6(D)
Weight	4.1 Kg

Notes

Service & Support

It is our goal to make owning and using Datavideo products a satisfying experience. Our support staff is available to assist you to set up and operate your system. Contact your local office for specific support requests. Plus, please visit www.datavideo.com to access our FAQ section.

Please visit our website for latest manual update.

www.datavideo.com/product/TLM-170K

www.datavideo.com/product/TLM-170KM

www.datavideo.com/product/TLM-170KR

datavideo
www.datavideo.com



@DatavideoUSA @DatavideoIndia2016
@DatavideoEMEA @Datavideojapan
@DatavideoTaiwan @DatavideoLatam
@DatavideoAsia @DatavideoBrasil



@Datavideo
@Datavideo_EMEA
@Datavideo_Taiwan



@DatavideoUSA
@DVTWDCN



@DatavideoUSA
@DatavideoEurope

All the trademarks are the properties of their respective owners.
Datavideo Technologies Co., Ltd. All rights reserved 2020

Dec-24.2025
Version E5