

May 2024

# Installation and Operation Manual

Blackmagicdesign 

# Blackmagic Videohub



Blackmagic Videohub 12G  
Universal Videohub  
Smart Videohub CleanSwitch 12x12

Videohub Master Control Pro  
Videohub Smart Control Pro  
Blackmagic GPI and Tally Interface

# Languages

To go directly to your preferred language, simply click on the hyperlinks listed in the contents below.

English	3
日本語	72
Français	142
Deutsch	212
Español	282
中文	352
한국어	422
Русский	492
Italiano	562
Português	632
Türkçe	702
Polski	772
Українська	842



## Welcome

Thank you for purchasing Videohub!

We hope you share our dream for the television industry to become truly creative by allowing anyone to have access to the highest quality video.

Previously, high end television and post production required investing in millions of dollars of hardware, and professional SDI routers have always been way too costly for most people to afford. HD-SDI is even more expensive and, until now, only the largest post production and television facilities could afford HD-SDI routing. Videohub changes all that! Some Videohub models not only give you HD-SDI, but also the latest Ultra HD format, enabling you to pipe 4K 60p video around your studio using 12G SDI.

This instruction manual contains all the information you'll need to install your Videohub, although it's always a good idea to ask a technical assistant for help if you are not sure what IP addresses are, or if you don't know much about computer networks. Videohub is easy to install, however there are a few slightly technical preferences you will need to set after you install it.

Please check our website at [www.blackmagicdesign.com](http://www.blackmagicdesign.com) and click the support page to download the latest updates to this manual and Videohub software. Lastly, please register your Videohub when downloading software updates so we can keep you updated when new software is released. We are constantly working on new features and improvements, so we would love to hear from you!

We hope you get years of use from your Videohub and have lots of fun connecting everyone in your facility together!

A handwritten signature in black ink that reads "Grant Petty". The signature is written in a cursive, flowing style.

**Grant Petty**

CEO Blackmagic Design

# Contents

<b>Introducing Blackmagic Videohub</b>	5	Setting Outputs to Cut Bus Mode	31
<b>Getting Started</b>	8	Creating Macros	31
Connecting Power	8	Button Mapping	32
Connecting Video	8	Setup Settings	33
Controlling your Videohub	8	<b>Updating your Videohub</b>	34
Switching a Route using the Built in Control Panel	9	<b>Blackmagic Videohub Control</b>	35
<b>Shortcut Buttons</b>	10	Selecting a Videohub	35
Using the Shortcut Buttons	11	Adding Pushbuttons	36
<b>Locking and Unlocking Routes</b>	13	Viewing Routes	36
<b>Connecting Videohub to a Network</b>	14	Switching Routes	36
Configuring Network Settings	15	Blackmagic Videohub Control at a Glance	37
<b>Smart Videohub CleanSwitch 12x12</b>	15	<b>Videohub Hardware Panel Setup</b>	46
<b>Videohub Hardware Control Panels</b>	16	Network Settings	46
Videohub Master Control Pro	16	Configuring Videohub Master Control Pro	48
Videohub Smart Control Pro	16	Configuring Videohub Smart Control Pro	49
Configuring the Control Panel	17	Configuring GPIs	52
Connecting to an Ethernet Network	17	Configuring Tally	53
Control Panel Button Diagnostics	18	<b>Developer Information</b>	57
About Routing Levels	19	Blackmagic Videohub Ethernet Protocol v2.8	57
How to Select Sources and Destinations	20	Saving and Loading Labels with Terminal in Mac OS	62
Using Videohub Smart Control Pro as a Cut-Bus Controller	25	Saving and Loading Labels with PuTTY in Windows	63
Using Videohub Smart Control Pro as an XY Controller	26	Videohub RS-422 Protocol	65
<b>Labeling Pushbuttons</b>	27	<b>Help</b>	68
<b>GPI and Tally Interface</b>	28	<b>Regulatory Notices</b>	69
<b>Blackmagic Videohub Software</b>	28	<b>Safety Information</b>	70
<b>Blackmagic Videohub Setup</b>	29	<b>Warranty</b>	71
Labeling Inputs and Outputs	29		

# Introducing Blackmagic Videohub

Your Blackmagic Videohub is part of a family of Videohubs designed for studios and facilities of any size. All Videohub models can be connected to an Ethernet network for external hardware control or by using Videohub Control software.

The Blackmagic Videohub 12G family includes a range of 12G-SDI routers with a built in control panel and support SD, HD and Ultra HD video standards up to 2160p60. These units can be mounted on a desk or installed in a rack using the supplied rack ears.



Blackmagic Videohub 10x10 12G



Blackmagic Videohub 20x20 12G



Blackmagic Videohub 40x40 12G



Blackmagic Videohub 80x80 12G



Blackmagic Videohub 120x120 12G

Rear connectors on Blackmagic Videohub 12G models include power, Ethernet, reference in, reference out and a USB-C connector for software updates.

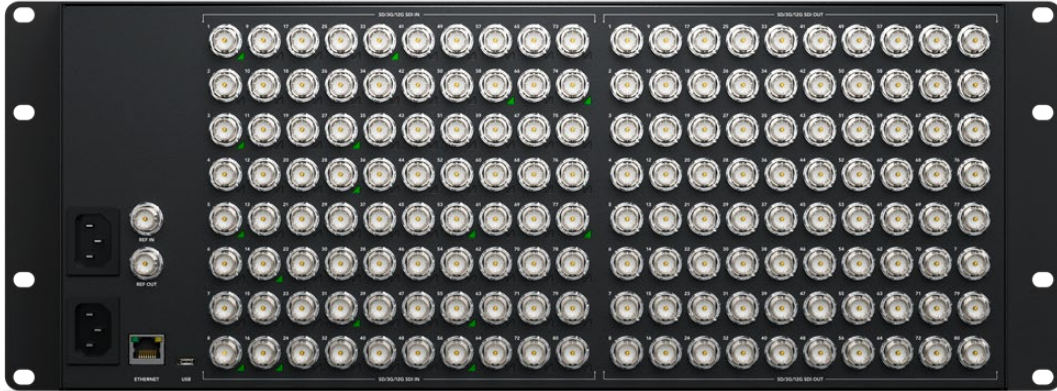

Blackmagic Videohub 80x80 12G rear

Universal Videohub 288 is a 3G-SDI Videohub designed for large facilities that allows routing of up to 288 HD sources and destinations.

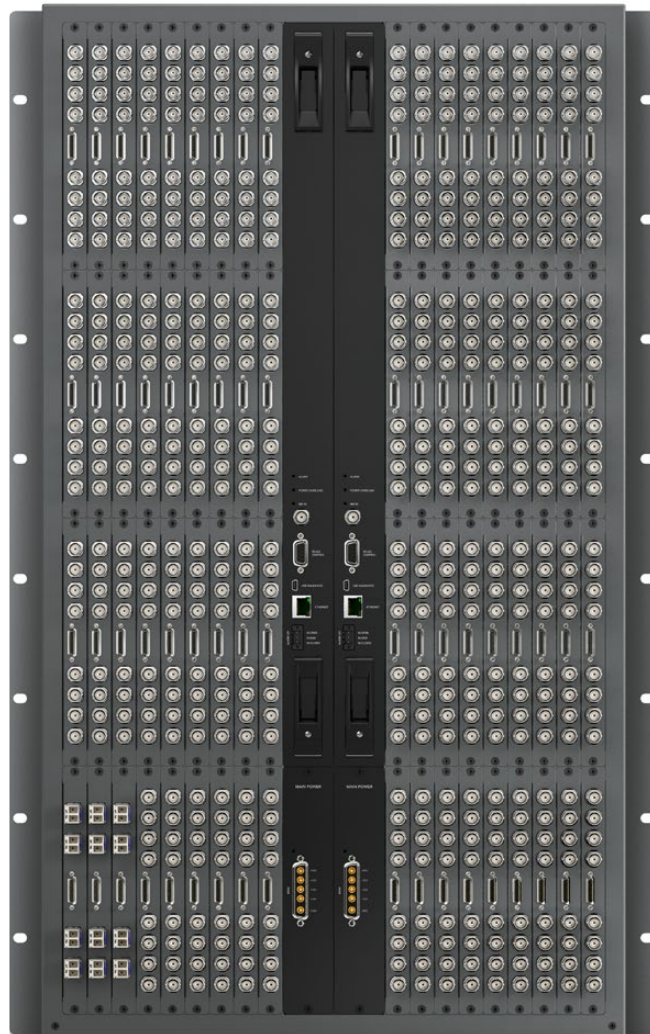

Universal Videohub 288

Smart Videohub CleanSwitch 12x12 is a 6G-SDI rack mountable Videohub with a built in resynchronizer on each input so you can switch routes cleanly to monitors or directly to air.



Smart Videohub CleanSwitch 12x12

Videohub Master Control Pro and Smart Control Pro are external hardware control panels that use the same filtering control available in Blackmagic Videohub 12G models. These units are designed to control any Videohub connected to the same Ethernet network.



Videohub Master Control Pro



Videohub Smart Control Pro

# Getting Started

Getting started with Videohub is as simple as connecting power and plugging in your video sources and destination equipment.

## Connecting Power

Connect power to the unit's power input via a standard IEC power connector.

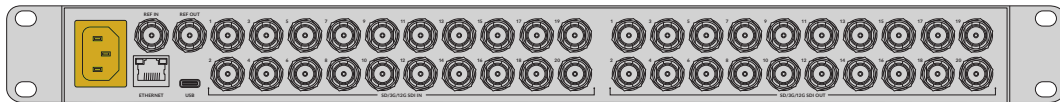

When you first turn on a Videohub 12G model, the LCD will ask you to select your chosen language. Scroll through the languages using the spin knob and press the 'set' button to confirm your selection.

## Connecting Video

- 1 Connect your video sources to your Videohub's SDI inputs.
- 2 Connect your destination equipment to your Videohub's SDI outputs.

The SDI connections will auto detect all supported video formats.

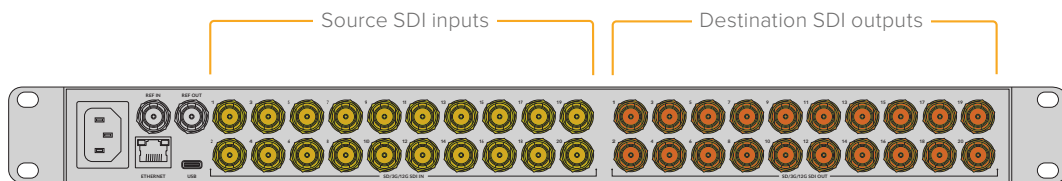

Connect your sources and destination equipment to your Videohub's SDI inputs and outputs

Green LEDs will illuminate on Videohub 80x80 12G when a valid signal is detected on the input.

## Controlling your Videohub

The fastest, most convenient way to control your Videohub is by using the unit's built in control panel. However, you can also change routes and settings remotely via USB or over Ethernet using an external Videohub hardware panel or by using the Blackmagic Videohub Control software. You can find more information about how to use the control software later in the manual.

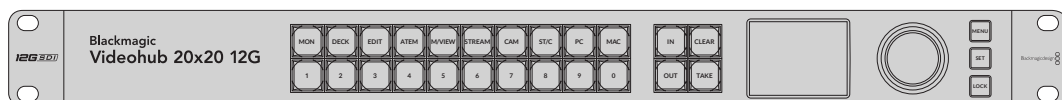

The built in control panel lets you change routes and settings using the buttons, LCD and spin knob

## Switching a Route using the Built in Control Panel

Switching a route is as simple as selecting the destination output and then selecting a source input to route to it.

### Selecting the Source and Destination

- 1 Press the 'out' button to enable the destination output selection.

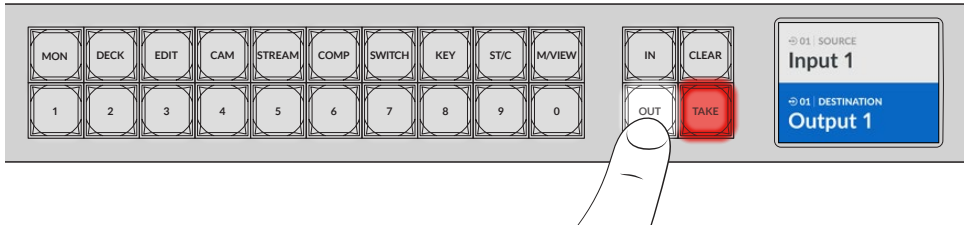

- 2 Press a numbered pushbutton to select a destination output. Alternatively, you can use the spin knob to scroll through the destinations.

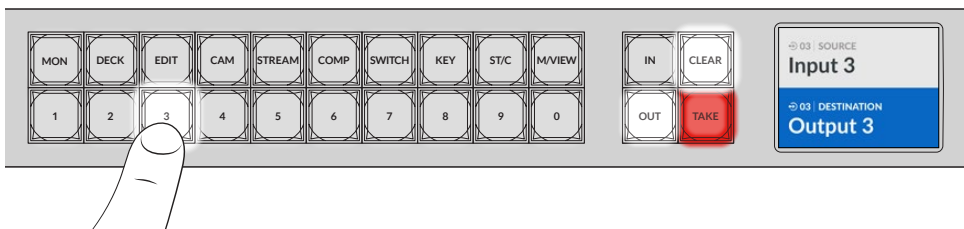

- 3 Now press the 'in' button to enable the source input selection.

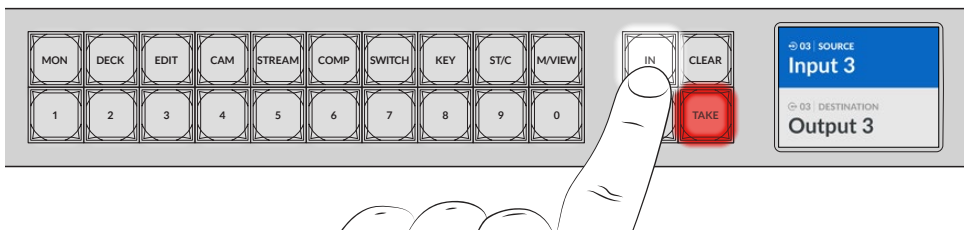

- 4 Press a numbered pushbutton to select a source input. Alternatively, you can also use the spin knob. When the source is selected, the 'clear' and 'take' buttons will flash indicating that you can confirm the route by pressing take, or cancel the route by pressing clear.

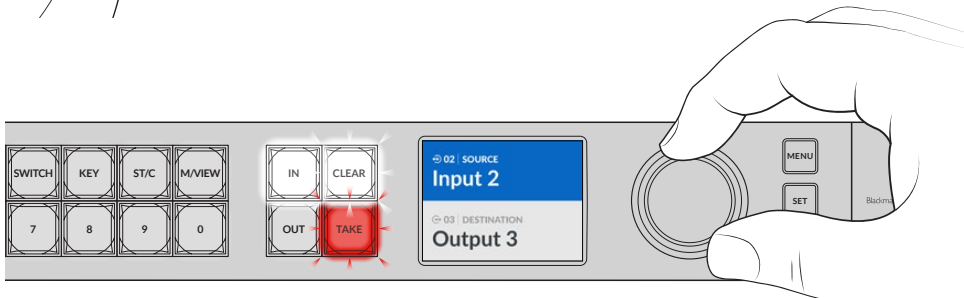
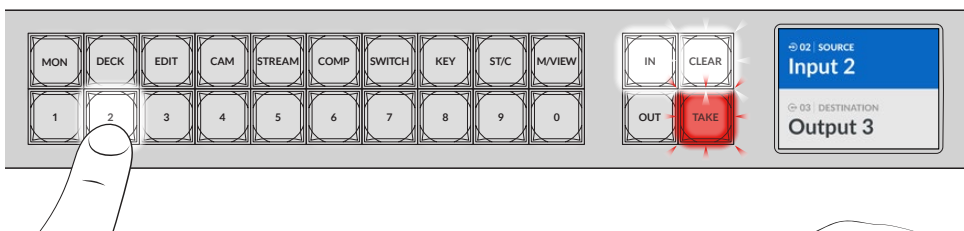

You can also use the spin knob to select your source and destination

5 Press 'take'.

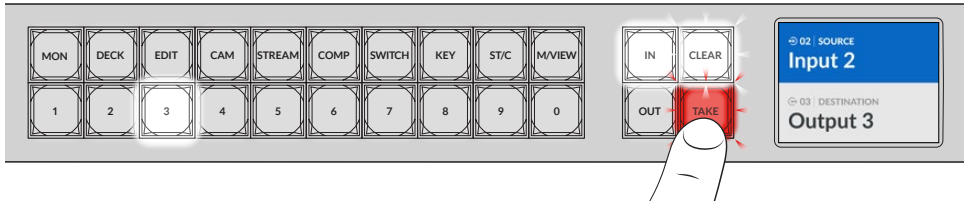

We have now completed a basic routing workflow using the source input and destination output buttons, plus the spin knob.

**TIP** To turn the 'in' button off, simply press it again to deselect it.

That's all there is to getting started with your Videohub! The next section of the manual will describe how to use the shortcut buttons.

## Shortcut Buttons

The labeled shortcut buttons above the numbered buttons let you make more specific selections using Videohub's built in filtering system.

Your Videohub is shipped with shortcut buttons already labeled to match common sources and destinations that are used in production facilities and studios. For example, 'DECK' for recording and playback decks, 'CAM' for cameras, 'EDIT' for edit bays, etc. When changing a route, you can narrow down your selection by pressing a shortcut button. This reduces the options to a smaller set, which can make the process faster when using larger Videohubs with a lot of equipment connected.

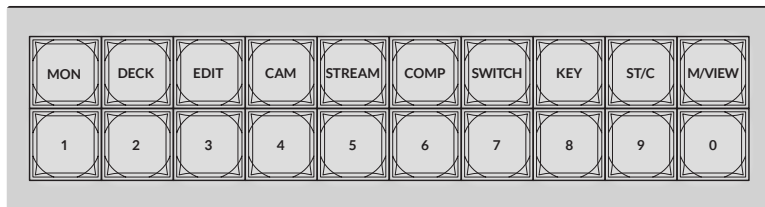

Use the shortcut buttons to take advantage of Videohub's alpha numeric filtering

**A Note about Shortcut Buttons**

Before you can use the shortcut buttons, you will need to label the inputs and outputs so the Videohub filtering system has labels to work with.

Labeling inputs and outputs is performed using Blackmagic Videohub Setup software. This utility is included in the free Videohub software available for download at the Blackmagic Support Center at [www.blackmagicdesign.com/support](http://www.blackmagicdesign.com/support)

We recommend installing the setup software and labeling your Videohub's inputs and outputs, then returning to this section for information on how to use the shortcut buttons. If you have already labeled the inputs and outputs, please continue reading this section.

For all information regarding Videohub software refer to the 'Blackmagic Videohub Software' section.

## Using the Shortcut Buttons

After the inputs and outputs have been labeled, the shortcut buttons can use Videohub's filtering to make faster selections.

To use the shortcut buttons:

### Select the Destination

- 1 Press the 'out' button to enable the destination selection.

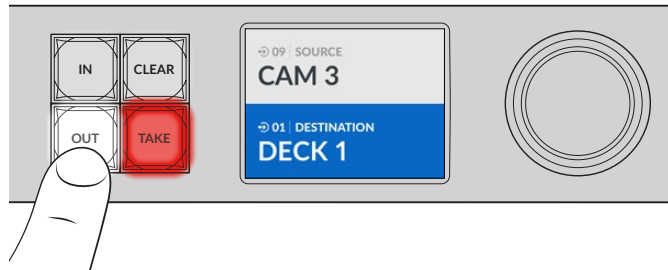

- 2 Press the shortcut button labeled 'DECK'.

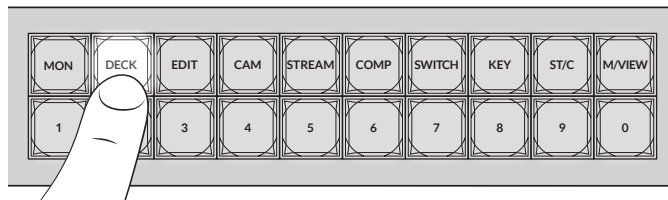

Your Videohub now makes all outputs available that include DECK in their label, filters out other destinations and then arranges them for selection on the numbered pushbuttons in numerical order.

- 3 Press button '2' to select 'DECK 2'.

Button '2' will illuminate and you can see the selected output and destination on the LCD.

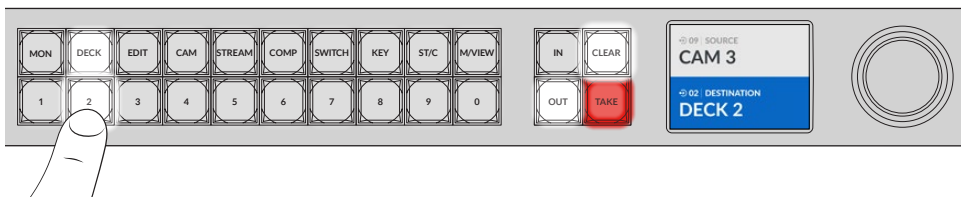

**TIP** If you have the LCD set to video monitoring you can see the video image currently routed to that destination plus the new source as you select it. Confirm the selection by pressing the 'take' button. Video monitoring can be enabled using the LCD menu or Blackmagic Videohub Setup.

## Select the Source

- 1 Press the 'in' button to enable the source selection.



- 2 Press the shortcut button labeled 'CAM'.

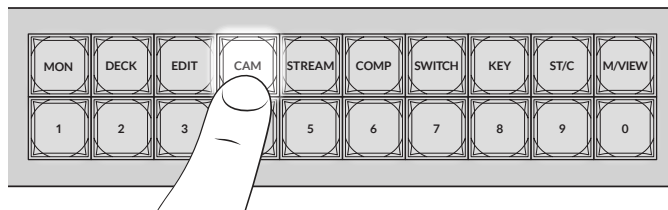

The filter now makes all inputs available that includes CAM in their label, filtering out other equipment and then arranges them on the numbered pushbuttons in numerical order.

- 3 Press button '2' to select 'CAM 2'.

Button '2' will illuminate and you can see the selected source and input on the LCD.

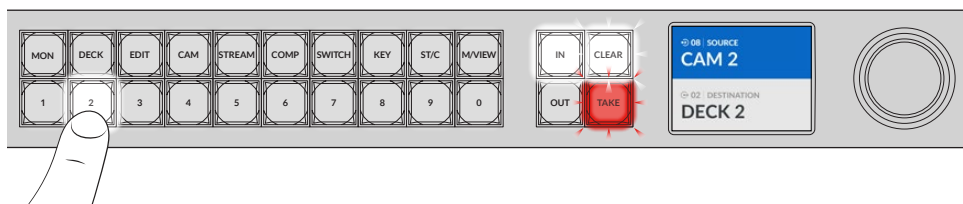

- 4 Press the 'take' button to confirm and complete the routing change.

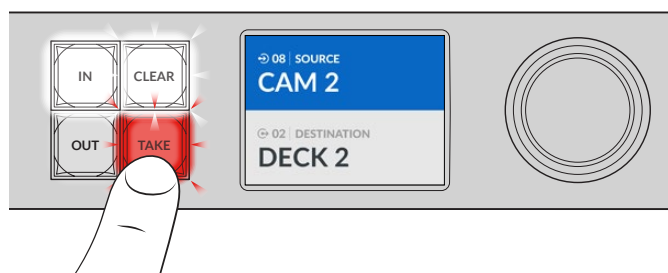

# Locking and Unlocking Routes

Locking and unlocking routes with your Blackmagic Videohub can be set easily using the integrated front panel. Press the 'lock' button to lock the currently selected output and you will see a lock indicator appear next to its name on the LCD.

If you want to lock a different output:

- 1 Press the destination button marked 'OUT'.
- 2 Now select a new destination by pressing the numbered and shortcut pushbuttons or by using the spin knob.
- 3 Press the 'lock' button.

You will see the lock indicator appear next to the output's name on the LCD. The lock button will also illuminate whenever that destination is selected to show that destination is locked and will not allow any new routes to be switched until it is unlocked.

To unlock the output, simply press the 'lock' button again.



To prevent routes from being switched on a specific output, press the lock button to lock the output

Another way to lock an output is to hold the 'out' button down for 2 seconds until you see the lock indicator appear on the LCD. To unlock the output, simply hold the output button down for another 2 seconds.



When a destination is locked a lock icon will appear on the LCD

**TIP** If a locked destination is selected, the source or input buttons will no longer select a source.

# Connecting Videohub to a Network

All Videohub models have an Ethernet port and can connect directly to your Ethernet network switch or a computer on your local area IP based network. This lets you control your videohub using Blackmagic Videohub Control software on a computer connected to the same network, or by using an external Videohub hardware control panel.

To connect Videohub to a network:

- 1 Connect power to your Videohub. On Universal Videohub models, make sure all power supplies are turned on.
- 2 Connect your Videohub router to the network switch or computer Ethernet port with a standard RJ45 Ethernet cable.

For Videohub models with a built in control panel, you can use the spin knob and buttons to configure IP address in the LCD menu, or use Blackmagic Videohub Setup. For Universal Videohub models, set your network settings using Blackmagic Videohub Setup.

If you have a Universal Videohub 288 populated with two crosspoint cards, connect Ethernet cables to both for network failover redundancy. Your Universal Videohub 288 will have a single IP address, despite having two Ethernet connections to the network switch.

Network settings adjustments using Blackmagic Videohub Setup can only be adjusted when connected to your Videohub via USB. The next section of the manual will describe how to change network settings using the built in control panel.

## Connecting to an Ethernet Network

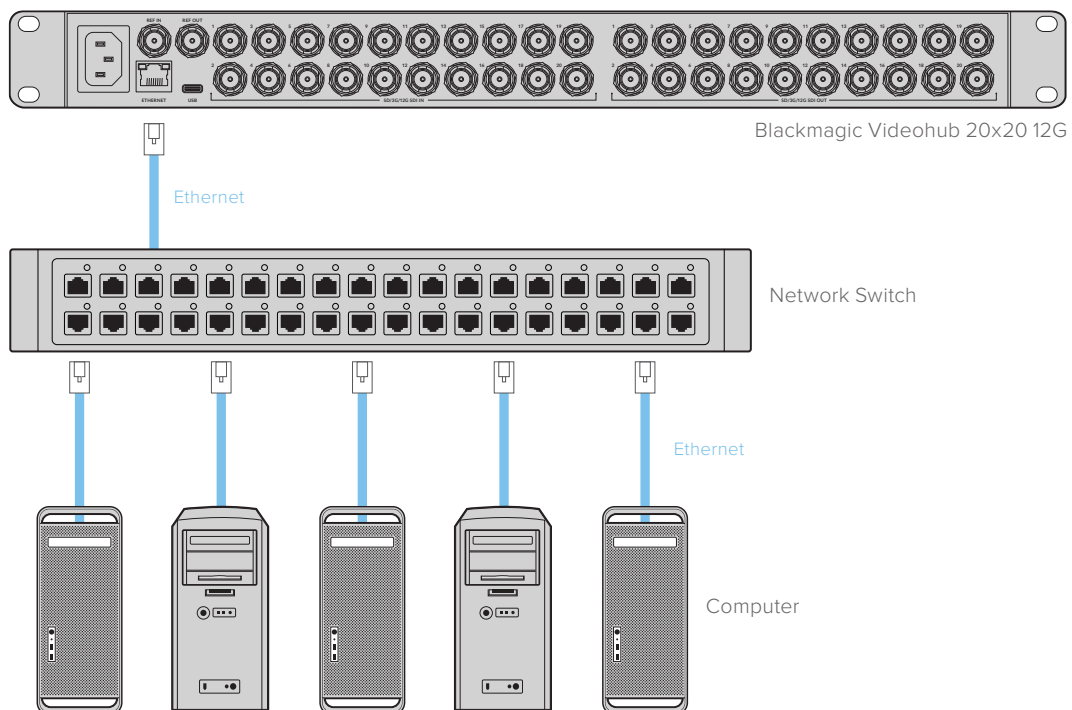

**NOTE** For information on how to connect Videohub hardware control panels to a Videohub unit on the network, refer to Videohub Hardware Panel Setup.

## Configuring Network Settings

Use your Videohub's built in control panel and LCD to configure network settings. Your router will be visible to other computers and hardware panels and these devices can then control the unit remotely and make routing changes.

To set the IP address using the front control panel:

- 1 Press the 'menu' button to open the 'settings' menu.
- 2 Use the spin knob to scroll down to 'network' settings. Press the 'set' button.
- 3 Rotate the spin knob to select the entry you want to change and press 'set' to confirm.
- 4 Use the spin knob to change a number field. Press the 'set' button to confirm the change and move through the fields.
- 5 Make sure you confirm the last change by pressing the 'set' button. You will know your settings are confirmed when the field entries are no longer highlighted.
- 6 Press the 'menu' button to exit the settings menu and return to your source and destination status.

If required, the subnet and gateway address can be set using the same method.

Network	
Protocol	Static IP
IP Address	192.168.24.100
Subnet Mask	255.255.255.0
Gateway	192.168.24.1

Press MENU to enter the network page and use the 'set' button and spin knob to set the IP address

## Smart Videohub CleanSwitch 12x12

When you need to cleanly switch between video sources to monitors or directly to air, you will need timed or genlocked signals. If you cannot guarantee perfectly timed source signals but you still need to clean switch, then you can use Smart Videohub CleanSwitch 12x12 as this model features resynchronization on all inputs so you get perfect clean feeds.

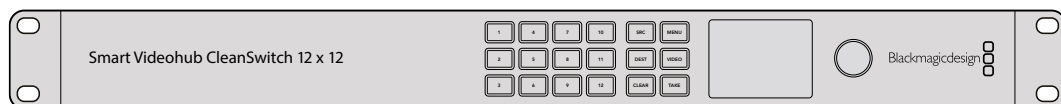

Smart Videohub CleanSwitch 12x12 includes full resynchronization on every input so the router automatically re times all inputs to ensure clean, glitch free switching between router cross points. Sources of the same resolutions and the same frame rate can even be output directly to air for smooth, cuts only production. The Smart Videohub CleanSwitch 12x12 will lock to the reference input or to Input 1 if no reference signal is connected. The video format of the reference signal and all inputs need to be identical for glitch free switching. You can still switch between mixed video formats, however they will not be synced.

## Videohub Hardware Control Panels

Videohub hardware control panels are external panels designed to let you control any Videohub that is connected to the same network. Both panels support power over Ethernet plus on compatible network switches, which means you can power the panels using the same connection via Ethernet port 1 and you don't need to connect a separate power cable. The second Ethernet port does not support PoE but can be used to loop other equipment to the network.

### Videohub Master Control Pro

Videohub Master Control Pro is a 1 rack unit mountable control panel with 36 backlit pushbuttons, LCD, scroll wheel and Ethernet connectivity designed to perform Videohub crosspoint switching without using a computer. Videohub Master Control Pro can control all sources and destinations for any size of Videohub router, as well as RS-422 deck control.

Videohub Master Control Pro uses port labels to aid in fast selection of equipment using software. Pushbuttons can be configured and labeled to provide fast selection of common equipment types, e.g., cameras, decks and monitors. It also includes a loop through Ethernet port for connecting to additional control panels, Videohub routers or other network devices. Macro buttons illuminate green when enabled and each one can be configured to perform up to 16 simultaneous crosspoint switches.

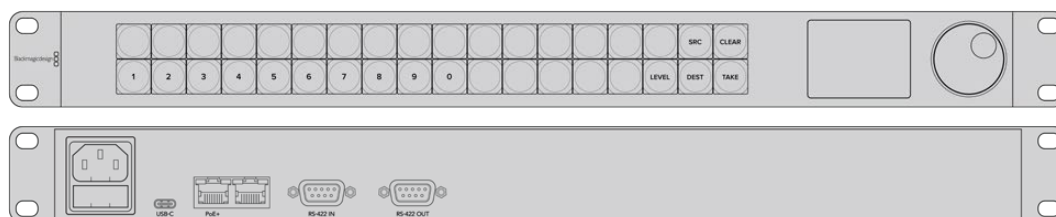

Videohub Master Control Pro

### Videohub Smart Control Pro

Videohub Smart Control Pro is a 1 rack unit mountable control panel with 48 backlit pushbuttons and Ethernet connectivity.

When configured for a single SDI destination, such as a monitor or deck, the pushbuttons can instantly switch between 48 different SDI sources on the same Videohub router. When configured for multiple SDI destinations, destination buttons become gold, source buttons become white and the lower right button can be configured as a take button and illuminates red. Macro buttons illuminate green when enabled and each one can be configured to perform up to 16 simultaneous crosspoint switches.

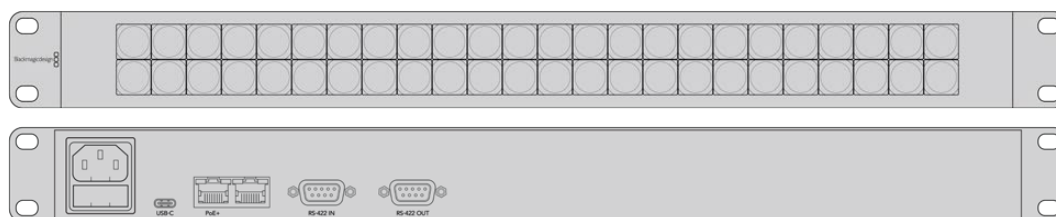

Videohub Smart Control Pro

## Configuring the Control Panel

A USB connection to a computer is used to configure the network settings of the Videohub Controller.

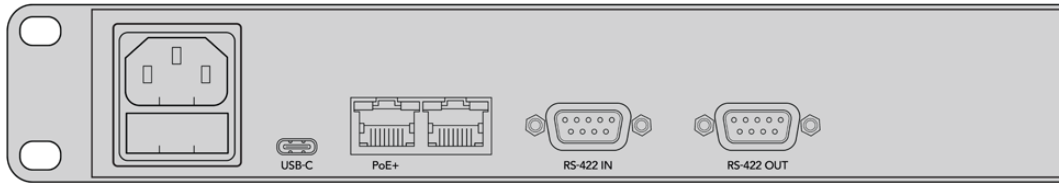

Plug the unit into a computer via USB-C to configure network settings

## Connecting to an Ethernet Network

In most facilities, Videohub is usually shared via an Ethernet network switch so it can be controlled by computers on the network as well as by Videohub control panels. Connect the control panel to the network as you would any Videohub router.

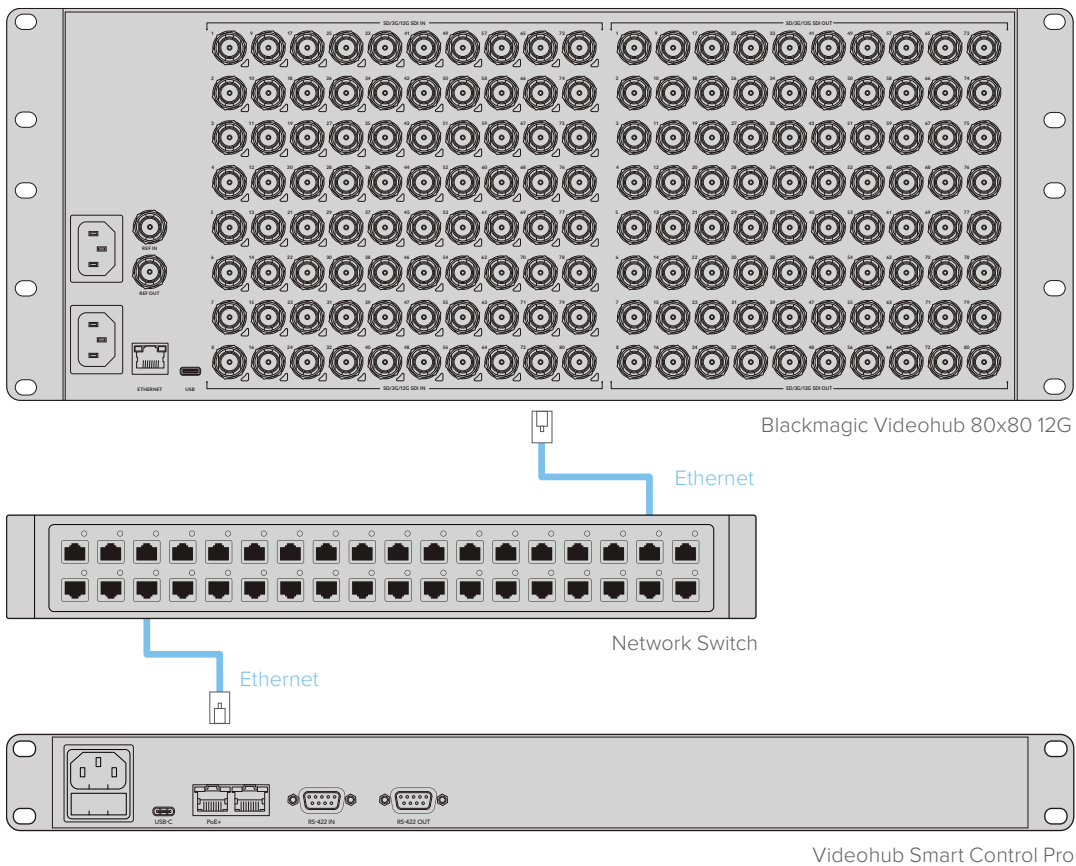

Videohub Smart Control Pro connected to a Blackmagic Videohub 80x80 12G via an Ethernet network switch

**NOTE** The second Ethernet port does not support PoE+ so a unit connected to the second port will require its own power supply.

## Control Panel Button Diagnostics

When power is first connected to a Videohub control panel, all the buttons will display their test lights in the following sequence: red, green, blue and white. The top left button of a Videohub control panel indicates its network status using the following diagnostic display:

### Pink Flashing Light

Unit is attempting to acquire an IP address. The button should quickly become red if the unit is set to use a static IP address, or if the unit successfully acquires an IP address from the DHCP server.

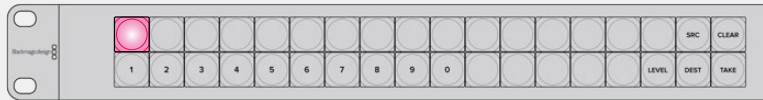

Videohub control panel is attempting to acquire an IP address

### Red Flashing Light

Unit has acquired an IP address and is attempting to connect to the Videohub Server. Make sure the Videohub or Videohub server is powered on and connected via Ethernet.



IP address has been acquired and control panel is attempting to connect to the Videohub server

### No Flashing Light

Unit has successfully connected to the Videohub server and is ready to control the Videohub if solid white, or solid white and gold, lights can be seen.

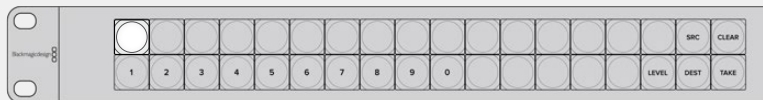

Control panel has successfully connected to the Videohub server

If the top left button took several minutes to turn red, the unit has failed to acquire an IP address and has eventually provided itself with a self-assigned AutoIP address in the 169.254.xxx.xxx format. Unless you wish to use an AutoIP address, disconnect and firmly reconnect the network cables to ensure they are properly connected, check for faulty network cables and make sure the DHCP server has spare IP addresses available. Unplug and reconnect all power sources from the Videohub control panel so it will request a new IP address from the DHCP server. The button should quickly become red. The unit will only perform these diagnostics when it is not selected in Videohub Hardware Panel Setup software.

## About Routing Levels

If your Videohub does not feature RS-422 remote deck control, Videohub Master Control will always show 'SDI' on its LCD and you don't need to read anything more about routing levels.

If your Videohub does include RS-422 remote deck control ports, you can use the LEVEL button on Videohub Master Control to reduce the list of sources and destinations by routing level.

Start by pressing the DEST button. Now press the LEVEL button to cycle through the routing levels:

### SDI 422

Choose this routing level to reduce the list of video equipment to devices with matching labels for their remote and SDI ports. This level is commonly used with SDI capture cards and VTR decks but cannot be used with cameras and monitors as they do not have RS-422 remote ports.

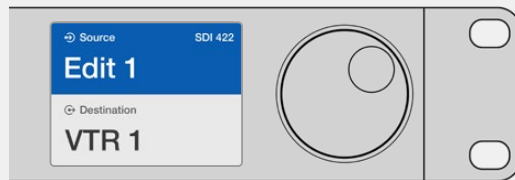

Choose the SDI 422 routing level if you only want to see SDI video equipment with RS-422 deck control. In this example, the capture card (Edit 1) and the deck (VTR 1) are listed because they both have SDI and RS-422 ports.

### SDI

Lists all SDI sources and destinations. Choose this routing level if you want to see all SDI video equipment, i.e., cameras, monitors, capture cards and VTR decks, regardless of RS-422 connections.



Choose the SDI routing level if you want to see all SDI video equipment. In this example, the capture card (Edit 1) and the deck (VTR 1) are listed because they both have SDI ports.

## 422

Choose this routing level if you want to reduce the list of video equipment to all devices with RS-422 deck control. This will list sources and destinations by the names of their RS-422 remote ports, regardless of whether there are any associated SDI ports and regardless of whether any associated SDI ports have matching labels or not. This level is commonly used with SDI capture cards and VTR decks but also lists remote control panels and servers used to control decks.



Choose the 422 routing level if you want to see all equipment with RS-422 remote deck control, including equipment with mismatched labels and also remote controllers. In this example, the capture card (Edit 1) has a mismatched label for its remote port (serial 1) and is only listed when the routing level is set to 422.

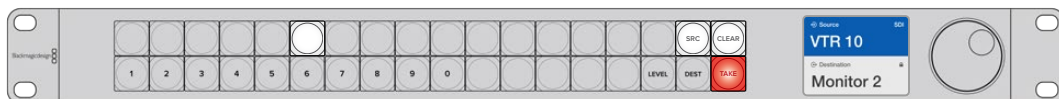

Front panel showing a new source has been selected.

## How to Select Sources and Destinations

Videohub Master Control Pro provides several ways to select and switch your destinations and sources quickly, depending upon whether you have customized the port labels on your Videohub router or if you just want to enter port numbers directly.

Videohub Master Control Pro works in the same conceptual way as any other router control.

- 1 Press the destination button marked 'DEST' to display a destination on the LCD. Use the pushbuttons or the scroll wheel to select the desired destination.
- 2 Press the 'take' button to confirm.
- 3 Press the source button marked 'SRC' and use the pushbuttons or scroll wheel to change the source.
- 4 Press TAKE to confirm the route change.

### Selecting units by typing the Videohub port numbers

If you've chosen to keep the default labels for all Videohub SDI and remote ports, you can simply type the port numbers to make a routing change. This method is fast but requires that you remember port numbers or have devised a system for knowing what equipment is connected to each Videohub port.

- 1 Press the destination button marked 'DEST'. The destination field will be highlighted blue on the LCD.
- 2 If your Videohub router has RS-422 remote control, press the LEVEL button until you have set the appropriate routing level for your equipment. Otherwise you can skip this step.

- 3 Type in the destination port number using the numeric pushbuttons. Each button will flash gold once as you press it. The destination will be displayed on the LCD. If you make a mistake, press the white 'clear' button and retype the port number.
- 4 Press the source button marked 'SRC'. The source field will be highlighted blue on the LCD.
- 5 Type in the source port number using the numeric pushbuttons. Each button will flash white once as you press it. The source will be displayed on the LCD. If you make a mistake, press the white 'clear' button and retype the port number.
- 6 The 'take' button will flash red, awaiting your confirmation of the route change. Press 'take' and the route will change immediately. Otherwise, press 'clear' and no route change will take place. Videohub Master Control returns to its idle state with the latest route displayed on the LCD.

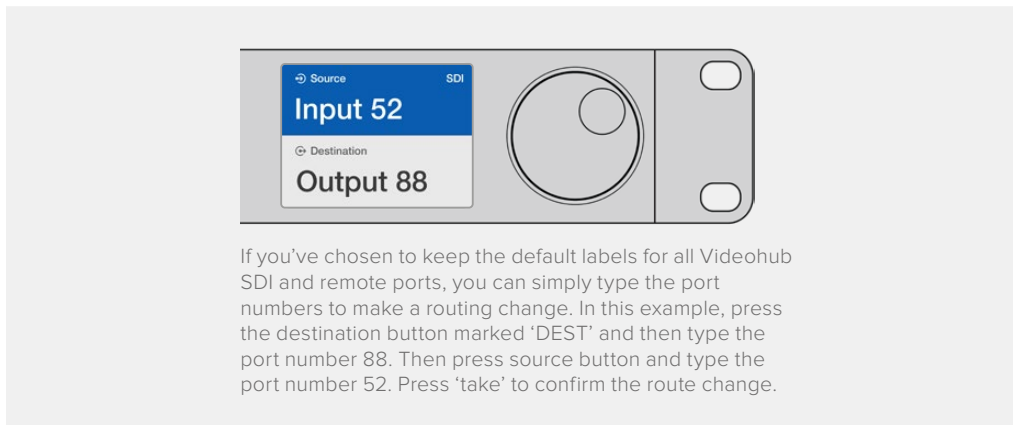

### Selecting Units using the Scroll Wheel

Regardless of whether or not you've customized the Videohub port labels, you can always use the scroll wheel to browse through a list of sources and destinations. This is the slowest method but is useful if you want to see the list of all available equipment and ports.

- 1 Press the destination button marked 'DEST'. The destination field will be highlighted blue on the LCD.
- 2 If your Videohub router has RS-422 remote control, press the 'level' button until you have set the appropriate routing level for your equipment. Otherwise you can skip this step.
- 3 Scroll the wheel forwards or backwards until the desired destination is found. The destination will be displayed on the LCD.
- 4 Press the source button marked 'SRC' so it illuminates white. The source field will be highlighted blue on the LCD.
- 5 Scroll the wheel until the desired source is found. The source will be displayed on the LCD.
- 6 The 'take' button will flash red, awaiting your confirmation of the route change. Press 'take' and the route will change immediately. Or press 'clear' and no route change will take place. Videohub Master Control returns to its idle state with the latest route displayed on the LCD.

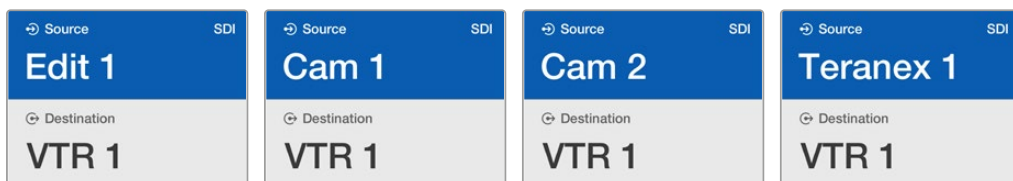

In this example, the scroll wheel is being used to list all sources that can be routed to the destination VTR 1, based upon the SDI routing level. When the scroll wheel is rotated, the names of source equipment are progressively displayed to make it very easy to find the desired video source.

## Selecting Units using Customizable Buttons and the Scroll Wheel

If you have customized the Videohub port labels, you can use the customizable buttons and scroll wheel together to find a short list of sources and destinations. This method is fast and intuitive because you only have to scroll through a short list of equipment and you don't have to remember any port numbers. This method is very helpful if you label types of equipment together by name, e.g., VTR, Cam and Mon.

- 1 Press the destination button marked 'DEST'. The destination field will be highlighted blue on the LCD.
- 2 If your Videohub router has RS-422 remote control, press the LEVEL button until you have set the appropriate routing level for your equipment. Otherwise you can skip this step.
- 3 Press a button you have customized for a type of destination equipment, e.g., VTR. The button should light up gold.
- 4 Scroll the wheel forwards or backwards until the desired destination is found. In this example, the destination VTR will be displayed on the LCD. If you make a mistake, press the white 'clear' button and scroll until the correct destination is displayed.
- 5 Press the source button marked 'SRC'. The source field will be highlighted blue on the LCD.
- 6 Press a button you have customized for a type of source equipment, e.g., a capture card. The button should light up white.
- 7 Scroll the wheel forwards or backwards until the desired source is found. In this example, the source capture card will be displayed on the LCD. If you make a mistake, press the white 'clear' button and scroll until the correct destination is displayed.
- 8 The 'take' button will flash red, awaiting your confirmation of the route change. Press 'take' and the route will change immediately. Otherwise, press 'clear' and no route change will take place. Videohub Master Control will then return to its idle state with the latest route displayed on the LCD.

If any button you have customized for either a source or destination flashes but does not stay lit, Videohub Master Control is preventing you from selecting the button because the equipment type has not been labeled as a source or destination device or does not match the current routing level. For example, cameras should not usually be set as destination devices, monitors should not be set as source devices and won't match the RS-422 routing level. Refer to *Configuring Videohub Master Control Pro* for steps on how to change this.

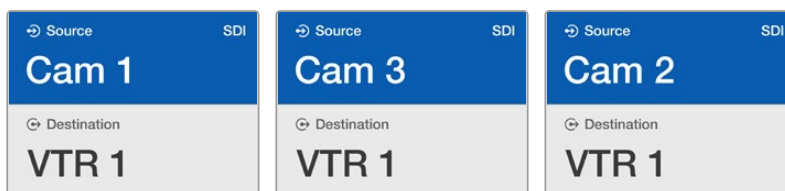

In this example, a customized Cam button has been selected so only cameras will be listed as sources, on the LCD, when the scroll wheel is rotated. This provides a fast way to find a video source because you only have to scroll through a short list of equipment.

## Selecting Units using Numeric Buttons and the Scroll Wheel

If you have customized the Videohub port labels with numbers, you can use the numeric buttons and scroll wheel together to find a short list of sources and destinations. This method is fast and intuitive because you only have to scroll through a short list of equipment and you don't have to remember any port numbers. This method is very helpful if you label groups of equipment together by numbers, perhaps to represent locations. For example, all the equipment in Studio 3 could be labeled VTR3, Edit 3, Cam 3A, Cam 3B, Mon 3A and Mon 3B etc.

- 1 Press the destination button marked 'DEST'. The destination field will be highlighted blue on the LCD.
- 2 If your Videohub router has RS-422 remote control, press the 'level' button until you have set the appropriate routing level for your equipment. Otherwise you can skip this step.
- 3 Using the numeric pushbuttons, type the destination number, e.g., 3 for Studio 3. Each numeric button will flash gold as you press it.
- 4 Scroll the wheel forwards or backwards until the desired destination is found. In this example, any of VTR 3, Edit 3, Mon 3A or Mon 3B could be displayed on the LCD. If you make a mistake, press the white 'clear' button and select another destination number.
- 5 Press the source button marked 'SRC'. The source field will be highlighted blue on the LCD.
- 6 Using the numeric pushbuttons, type the source number, e.g., 3 for Studio 3. Each numeric button will flash white as you press it.
- 7 Scroll the wheel forwards or backwards until the desired source is found. In this example, any of VTR 3, Edit 3, Cam 3A or Cam 3B could be displayed on the LCD. If you make a mistake, press the white 'clear' button and select another source number.
- 8 The 'take' button will flash red, awaiting your confirmation of the route change. Press 'take' and the route will change immediately. Otherwise, press 'clear' and no route change will take place. Videohub Master Control will then return to its idle state with the latest route displayed on the LCD.



In this example, the numeric button "3" has been selected so only video sources with a "3" in their label will be listed, on the LCD, when the scroll wheel is rotated. This provides a fast way to find a video source because you only have to scroll through a short list of equipment based upon a group number, e.g. only list the equipment in Studio 3.

## Selecting Units using Both Customizable and Numeric Buttons

If you have customized the Videohub port labels with names and numbers, you can use the customizable buttons and numeric buttons together to directly select sources and destinations. This method is very fast and intuitive because you don't have to scroll through a list of equipment and you only have to remember how many of each type of equipment you have, e.g., two VTRs and four monitors.

This method is very helpful if you label types of equipment by name and number, e.g., VTR 01, VTR 02, Cam 01, Cam 02, Cam 03, Mon 01, Mon 02, Mon 03 and Mon 04.

- 1 Press the destination button marked 'DEST'. The destination field will be highlighted blue on the LCD.
- 2 If your Videohub router has RS-422 remote control, press the LEVEL button until you have set the appropriate routing level for your equipment. Otherwise you can skip this step.
- 3 Press a button you have customized for a type of destination equipment, e.g., VTR. The button should light gold.
- 4 Type in the destination equipment number using the numeric pushbuttons, e.g., 07 for VTR 07. Each numeric button will flash gold as you press it.
- 5 Press the source button marked 'SRC'. The source field will be highlighted blue on the LCD.

- 6 Press a button you have customized for a type of source equipment, e.g., a capture card. The button should light white.
- 7 Type in the source equipment number using the numeric pushbuttons, e.g., 03 for the capture card Edit 03. Each numeric button will flash white as you press it.
- 8 The 'take' button will flash red, awaiting your confirmation of the route change. Press 'take' and the route will change immediately. Otherwise, press 'clear' and no route change will take place. Videohub Master Control will then return to its idle state with the latest route displayed on the LCD.

If any button you have customized for either a source or destination flashes but does not stay lit, Videohub Master Control is preventing you from selecting the button because the equipment type has not been labeled as a source or destination device or does not match the current routing level. For example, cameras should not usually be set as destination devices, monitors should not be set as source devices and won't match the RS-422 routing level. Refer back to Creating Button Labels in Configuring Videohub Master Control Pro for steps on how to change this.



## Locking and Unlocking Routes

To lock a destination using Videohub Master Control:

- 1 Set the destination and source using whichever method you prefer. Once the route has been set, Videohub Master Control will return to its idle state.
- 2 Press the destination button marked 'DEST'. The destination field will highlight blue on the LCD.
- 3 If the desired route is not already displayed on the LCD, use the pushbuttons and/or scroll wheel to find the destination to be locked.
- 4 Press and hold the gold destination button until a lock icon appears in the destination field of the LCD.
- 5 Press 'destination' again to return Videohub Master Control to its idle state and the destination field will revert to gray.

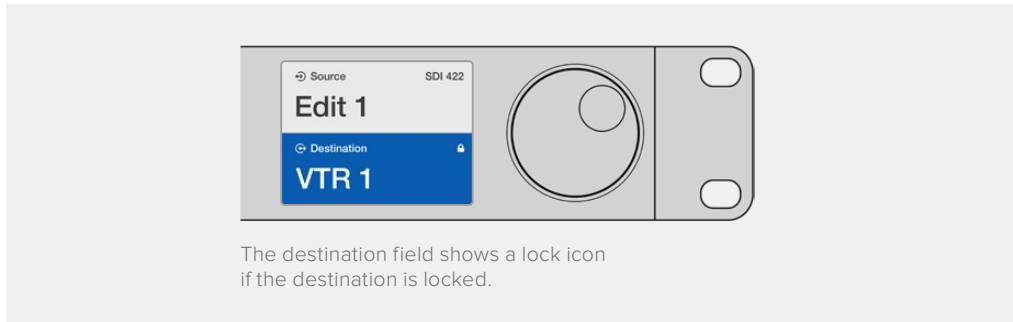

To unlock a destination using Videohub Master Control:

- 1 Press the destination button marked 'DEST'. The destination field will highlight blue on the LCD.
- 2 If the desired route is not already displayed on the LCD, use the pushbuttons and/or scroll wheel to find the destination to be unlocked. The destination field will show a lock icon for the locked destination.
- 3 Press and hold the gold DEST button until the lock icon disappears from the destination field of the LCD.
- 4 Press DEST again to return Videohub Master Control to its idle state and the destination field will revert to gray.

### Using Macros

If you press a green macro button, it will simultaneously make the crosspoint changes you have previously configured in Videohub Hardware Panel Setup. Each button can be configured with up to 16 crosspoint routes. If you have the Take button enabled, the simultaneous change of routes will only take place when you confirm by pressing the Take button. If for any reason the macro cannot be performed, the button will flash.

### Using Videohub Smart Control Pro as a Cut-Bus Controller

If Videohub Smart Control Pro has been configured as a Cut-Bus controller, the destination device has already been chosen and you only need to choose a video source.

- 1 Select a white video source button. The button will light up to distinguish it from the other sources. The video source will immediately connect and be viewable on the destination device.
- 2 If the Take button has been enabled, the new source button and the Take button will flash. The route change will only take place when you confirm by pressing the Take button.

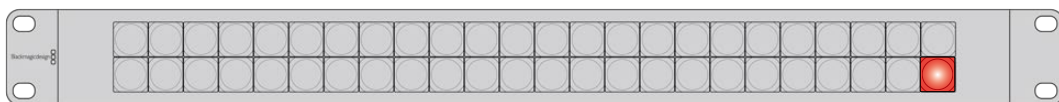

Videohub Smart Control Pro configured as a Cut-Bus controller and with a Take button

## Using Videohub Smart Control Pro as an XY Controller

If Videohub Smart Control Pro has been configured as an XY controller, destination buttons light up gold and source buttons light up white. When working with multiple destinations, always select a destination button before selecting a source button.

To change routes:

- 1 Select a gold destination button and it will light up brightly to distinguish itself from the other destination buttons. If a video source has previously been connected to this destination, its button will light up white.
- 2 To connect a new source to the destination, press the desired video source button. The video source will immediately be connected and viewable on the destination device. The new source button will be brightly lit and the previous source button will dim to normal. To change another route, select another destination button and then select a new source button.
- 3 If the 'take' button has been enabled, the new source button and the 'take' button will flash. The route change will only take place when you confirm by pressing the 'take' button.

### Locking and Unlocking Routes

To lock a destination, press and hold the desired destination button until it turns blue. The corresponding source button will illuminate. If you attempt to change sources for a locked destination, the destination button will flash blue. To unlock a destination, press and hold the button until it returns to the standard gold color.

### Using Macros

If you press a green macro button, it will simultaneously make the crosspoint changes you have previously configured in Videohub Hardware Panel Setup. Each button can be configured with up to 16 crosspoint routes. If you have the Take button enabled, the simultaneous change of routes will only take place when you confirm by pressing the Take button. If for any reason the macro cannot be performed, the button will flash.

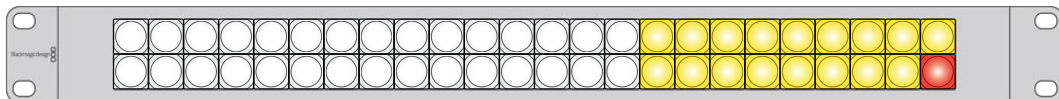

Videohub Smart Control Pro configured as an XY controller and with a Take button

# Labeling Pushbuttons

Videohub Master Control Pro, Videohub Smart Control Pro and Videohub 12G models have removable pushbuttons that provide access for labeling.

Included with the software installer is a 'Videohub control labels' folder containing a PDF template file. Fill out and print the PDF file labels, then cut out the squares to be inserted into the buttons.

To remove the buttons:

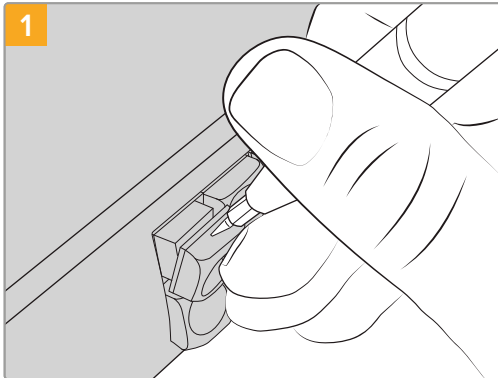

The button keycaps can be easily removed using a small flathead screwdriver.

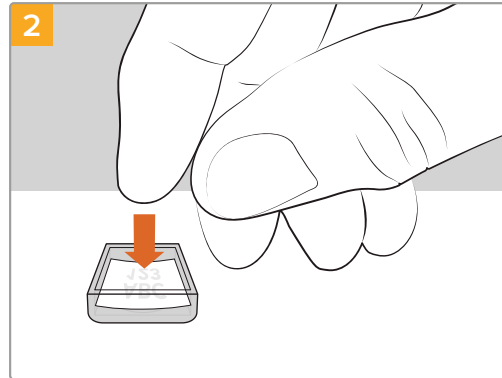

Loosely place your new printed label into the upturned clear keycap.

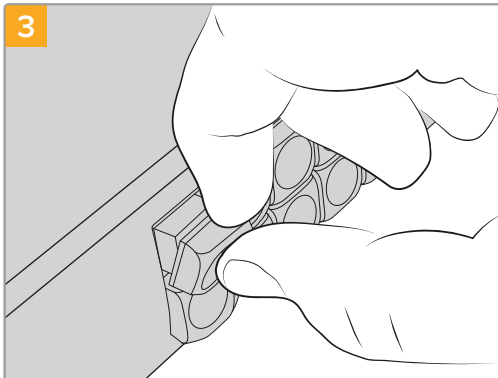

Replace the keycap by aligning it onto the button and gently pushing until you feel it click into place.

# GPI and Tally Interface

The Blackmagic Design GPI and Tally Interface is a low cost alternative for multi-camera productions where a camera control unit, or CCU, operator needs to switch video from one of several cameras being controlled to a single monitor. It features 8 configurable GPIs and 8 configurable GPOs.

Under certain crosspoint conditions, the GPIs send commands to your Videohub via Ethernet to switch the selected camera to the operator's monitor and the GPOs send a tally signal to your cameras or other equipment.

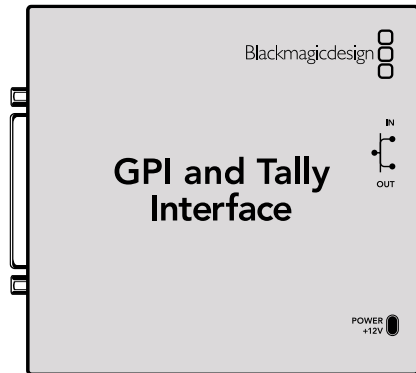

GPI and Tally Interface

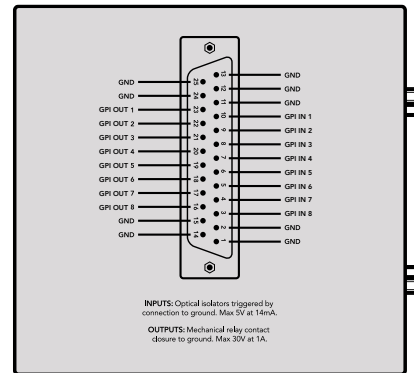

Pinout diagram of the DB25 connector

Refer to the pinout diagram on the back of the unit when fabricating your custom cable.

For information on how to configure your GPI and Tally Interface using Blackmagic Videohub Setup, refer to the 'Blackmagic Videohub Software' section of this manual.

## Blackmagic Videohub Software

Blackmagic software includes three important software applications used to configure and control your Videohub and Videohub hardware panels. Download the Blackmagic Videohub Software from the Blackmagic Support Center at [www.blackmagicdesign.com/support](http://www.blackmagicdesign.com/support)

Blackmagic Videohub software includes the following applications:

**Blackmagic Videohub Setup.** This is an administration utility for changing settings, configuring your Videohub and updating the unit's internal software.

**Blackmagic Videohub Hardware Panel Setup.** This utility is used to configure Videohub Master Control Pro and Smart Control Pro hardware panels.

**Blackmagic Videohub Control.** This application is a software control panel that lets you control your Videohub remotely via USB or over an Ethernet network.

# Blackmagic Videohub Setup

Using Blackmagic Videohub Setup, you can label the inputs and outputs to identify sources and destinations, plus maximize the results of your Videohub's filtering system when using the shortcut buttons. You can also create macros, map shortcut buttons and more.

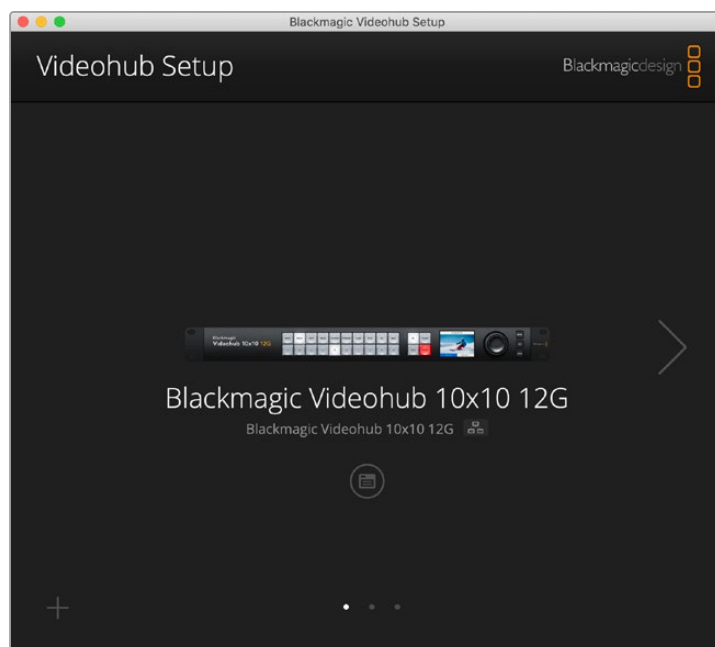

The first step is to download and install the Videohub software onto your Mac or Windows PC. The software is freely available at [www.blackmagicdesign.com/support](http://www.blackmagicdesign.com/support)

Once installed on your computer, connect your Videohub via USB then go to your applications folder and launch Blackmagic Videohub Setup.

The first screen you will see is the home screen. This is where you can select your Videohub if you have more than one unit connected. Simply click on the left and right arrows to move through the units.

To open your Videohub's settings, click on the settings icon under the image of your Videohub.

## Labeling Inputs and Outputs

The 'inputs' and 'outputs' tab lets you change the labels for all your source inputs and destination outputs.

To label a source and output:

- 1 Click in a source or destination's text field.
- 2 Type a new name. Press the return key on your computer keyboard to move to the next field, or simply click in the next text field to select it.
- 3 When you have entered all the labels, click 'save'.

It's important to label them so they match the shortcut button labels on the unit, for example DECK for playback and recording decks, MON for monitor destinations, etc. If you want to change them to something else, you should also change the physical shortcut button labels on the unit to make sure they correspond. You can find information on how to change the pushbutton labels in the 'labeling pushbuttons' section.

**TIP** Videohub text filtering is case sensitive.

Once you have labeled your source inputs and destination outputs, you can also save them as a label set. This means if you need to change the labels for a new project, you can always reload the previous set you saved earlier. You can also modify the input and output labels using a simple text program such as text editor.

To save a label set:

- 1 Click on the gear icon at the bottom of the inputs or outputs settings and select 'save label set'.
- 2 Type a name for the label set and choose the save location. Click 'save'.

To edit a label set:

- 1 Locate the text based label file you've just saved and open in in a text based program such as TextEdit.
- 2 Replace the current label name using the text editor. Save the changes. Now when you load the label set, the new label will appear.

To load a label set:

- 1 Click on the gear icon at the bottom of the inputs or outputs settings and select 'load label set'.
- 2 Choose the label set you have previously saved and click 'open'.

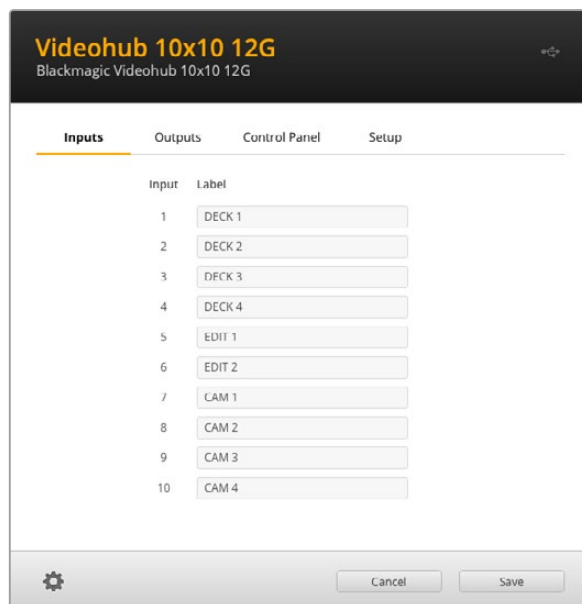

**NOTE** Port labels on an IP Videohub cannot be edited as these labels derive from the connected IP Video devices. The labels are stored on the connected Videohub and are also visible on the other control panels connected to your network.

## Setting Outputs to Cut Bus Mode

In the output settings you will notice checkboxes next to each output. These let you set them to cut bus mode. When an output is set to use cut bus mode, it will change the route the moment a source is selected without using the take button to confirm it.

You can select which destinations use cut bus mode individually, or enable and disable cut bus mode on all outputs by clicking 'all on' or 'all off' buttons.

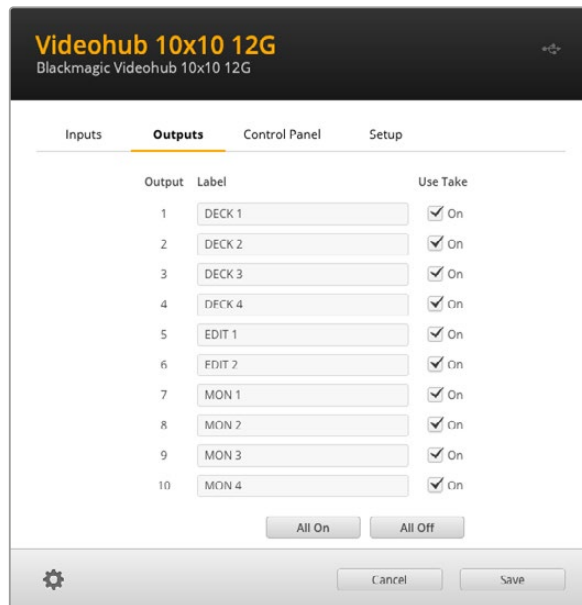

Cut bus mode will switch a route without using the take button

## Creating Macros

The control panel tab also lets you create macro buttons and assign their functions.

Click and drag the 'number of macros' slider to the right to add macro buttons and drag left to remove them. As you add macro buttons you will see the buttons in the utility illuminate white.

To assign a macro to a macro button:

- 1 Click on a white macro button in the 'button mapping' section. You will see a menu appear underneath with rows from A to P. Each row represents a routing action.
- 2 In the 'A' row's 'source' menu, select the input source and then select the destination output.
- 3 Click 'save'.

The macro is now assigned to a macro button.

The macro assigned in steps 1 to 3 assigns a single routing action to the macro button, but you can also add a range of other actions to happen simultaneously when that macro is performed. For example, you may have a project setup that contains a complex sequence of routing changes. In this case, the entire sequence can be assigned to a single macro button. It's very powerful!

To activate a macro, simply press the macro button on the panel and then press 'take' to confirm the switch.

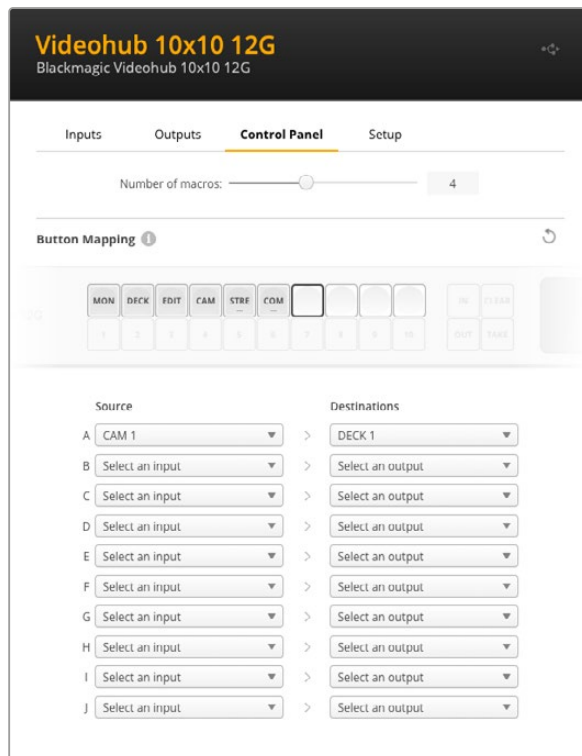

Macros let you perform multiple simultaneous routes

## Button Mapping

The labeled shortcut buttons on your Videohub's control panel are used to select groups of equipment when changing routes. For example, if you have 3 HyperDeck sources with their inputs labeled DECK 1, DECK 2 and DECK 3, you can press the DECK shortcut button to reduce the selection to only those 3 sources. The reduced sources can then be selected using the spin knob or by pressing pushbuttons 1, 2, or 3. This is especially helpful when using larger Videohubs with many types of equipment connected.

If you want to create a new shortcut button label, it's important to also change the corresponding physical button label on the unit. Refer to the 'labeling pushbuttons' section for more information.

To map a shortcut button label:

- 1 Click on a labeled shortcut button and type a label in the text field. It's important to keep the label consistent with the corresponding input and output labels. For example, if your HyperDeck sources are labeled DECK 1, DECK 2, DECK 3, etc, they will be recognized by a shortcut button mapped with the label 'DECK'.
- 2 Click 'save'.

Refer to the 'shortcut buttons' section for information on how to use mapped shortcut buttons when switching a route.

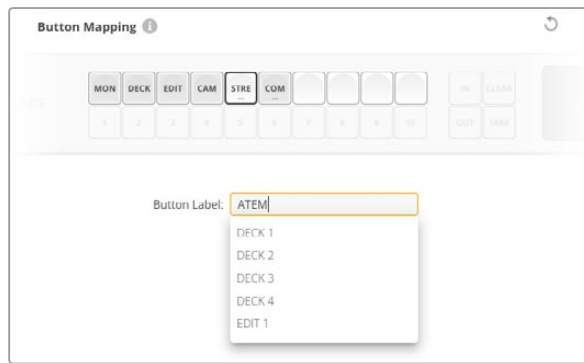

Type a new name for the shortcut button and click 'save'

## Setup Settings

The setup settings tab lets you name your Videohub so you can identify it on a network. Simply type in a name and then click on the 'set' button.

To change the language used on your Videohub's LCD, click in the language menu, select your language and click 'save'.

The software version is displayed so you can check it against the latest version on the Blackmagic Design support center at [www.blackmagicdesign.com/support](http://www.blackmagicdesign.com/support)

## Video Monitoring

When video monitoring is enabled, the LCD will show a preview of the source currently routed to a destination. For example, if you press the destination button and select an output, you will see the source currently routed to that output.

Additionally, you can also check the source video before switching the route. For example, scrolling through the sources using the spin knob lets you visually confirm the desired video feed.

If you want to disable the video preview mode, deselect the 'video monitoring' setting in the 'setup' settings tab. This returns the LCD to the home screen, displaying the standard source and destination text view.

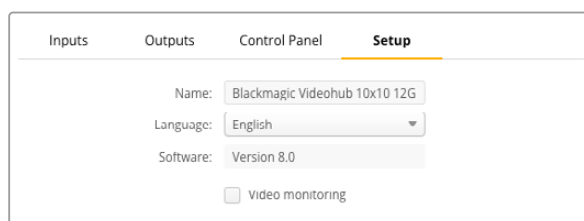

Deselect the 'video monitoring' checkbox to disable the source and destination video preview mode on the LCD

## Network

The network settings let you set the unit to use DHCP for automatic network connection, or static IP if you need to manually set an IP address.

The network settings can be changed when your Videohub is connected to a computer via USB.

To help limit the potential for accidental administration changes, Blackmagic Videohub Setup can be set to only allow users to make settings changes via USB. To enable, select 'via USB'.

Network settings are important for controlling your Videohub over a network using Videohub Control software or an external hardware control panel, for example controlling a Blackmagic Videohub 40x40 12G using Videohub Master Control Pro. Refer to the 'connecting Videohub to a network' section for more information about network settings.

## Reset

The factory reset button deletes all assigned macros and labels and restores the unit to its original factory settings.



# Updating your Videohub

Occasionally, the internal software in your Videohub will need to be updated. Updates to internal software can provide new features, compatibility with new hardware and support for new formats.

Please follow these steps to update your Videohub's internal software:

- 1 Connect your computer to the Videohub's USB connector.
- 2 Launch Blackmagic Videohub Setup and it will automatically display any Videohubs that are connected to your network.
- 3 Select your Videohub by clicking on either the picture or the configuration icon.
- 4 The utility will inform you if an update is required.
- 5 If an update is required, click the Update button and allow the software to install. Make sure not to unplug the Videohub while the update is in progress.
- 6 Click the Close button when the update is finished.

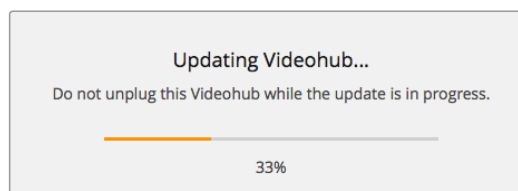

Do not unplug the Videohub while the update is in progress

# Blackmagic Videohub Control

Using Blackmagic Videohub Control provides a fast and intuitive way to view and switch between multiple sources and destinations remotely. Videohub Control is easy to use because it operates on a single video output at a time. Selecting a destination or output pushbutton shows which source or input is connected to it by illuminating the source pushbutton. To change the source, simply click on a different source pushbutton. It's that easy!

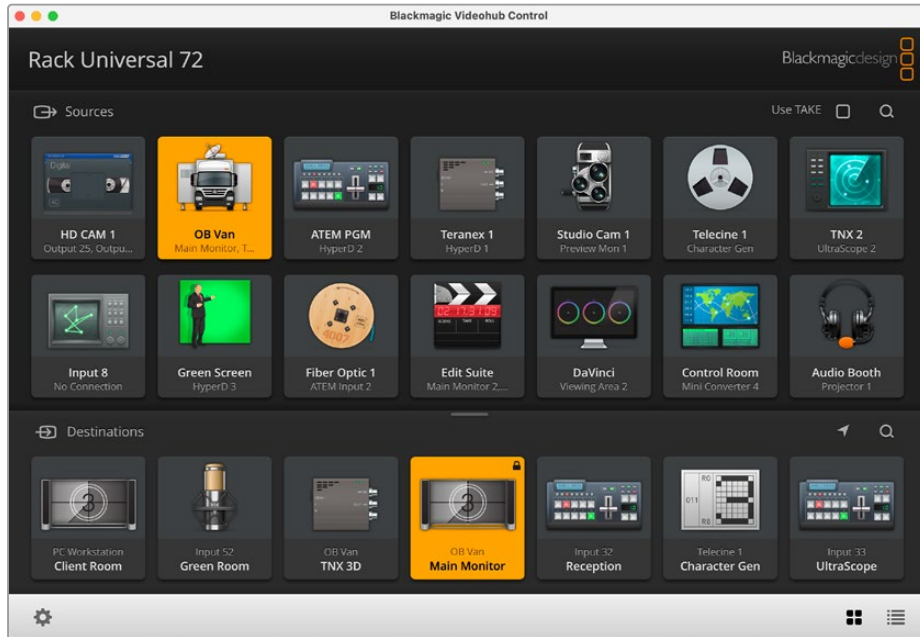

Videohub Control provides an intuitive, icon driven representation of the Videohub connections

## Selecting a Videohub

Launch Blackmagic Videohub Control, click on the settings gear icon and choose 'select Videohub'. Click on the Videohub that you wish to control. If you have customized your labels, the names you assigned will appear within the software. All Videohubs on the network, including IP Videohubs, will appear in this list.

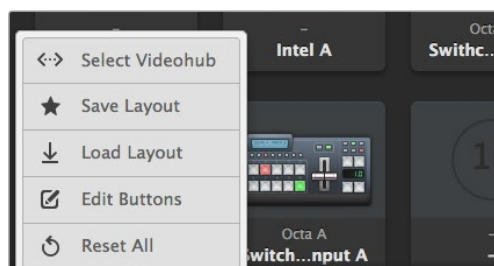

Click on the 'select Videohub' option and then select the Videohub you wish to control

## Adding Pushbuttons

Click on the settings gear icon and then select 'edit buttons'. Click on the 'add' button and choose whether to add a source or destination pushbutton. The 'set button' window appears and allows you to set the SDI source or destination, RS-422 deck control and icon for the pushbutton. In most cases, deck control is grouped with the associated SDI connections.

## Viewing Routes

In order to see which video source has been routed to a video destination, such as a monitor, press the button in the destinations panel to make the button illuminate. The associated video source button will illuminate in the sources panel, making it immediately obvious which source is connected to the monitor.

## Switching Routes

In order to change the video source from a tape deck to a video camera, press a camera pushbutton in the sources panel to immediately illuminate the camera pushbutton and route video to the video monitor. The tape deck button is no longer illuminated and is disconnected from the video monitor.

<b>Resizing the Interface</b>	Click and drag the bottom right hand corner to proportionally resize the interface to best fit your screen size. Alternatively, drag a window edge to resize either vertically or horizontally.
<b>Resizing the Sources and Destinations Areas</b>	Drag the divider bar up and down and use the scroll bars to scroll the respective areas.
<b>Switching Views</b>	You can switch between pushbutton view and list view by clicking the icons in the bottom right corner.
<b>Using the Dynamic Search</b>	Both the sources and destinations areas contain a search icon, which allows you to search for text dynamically. This is useful if you have many pushbuttons and quickly want to locate a pushbutton with a specific name. Begin by typing the name you wish to search for. As you type each letter, the pushbuttons that are displayed will be dynamically filtered.

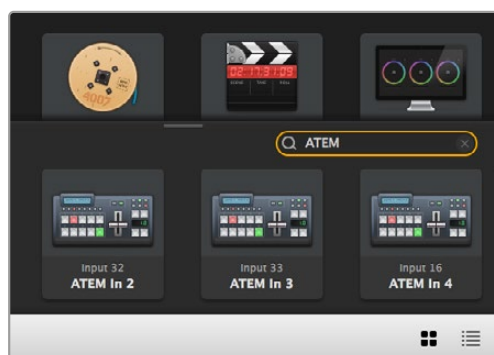

The word 'ATEM' is entered into the destinations search box and the filtered results are displayed

## Blackmagic Videohub Control at a Glance

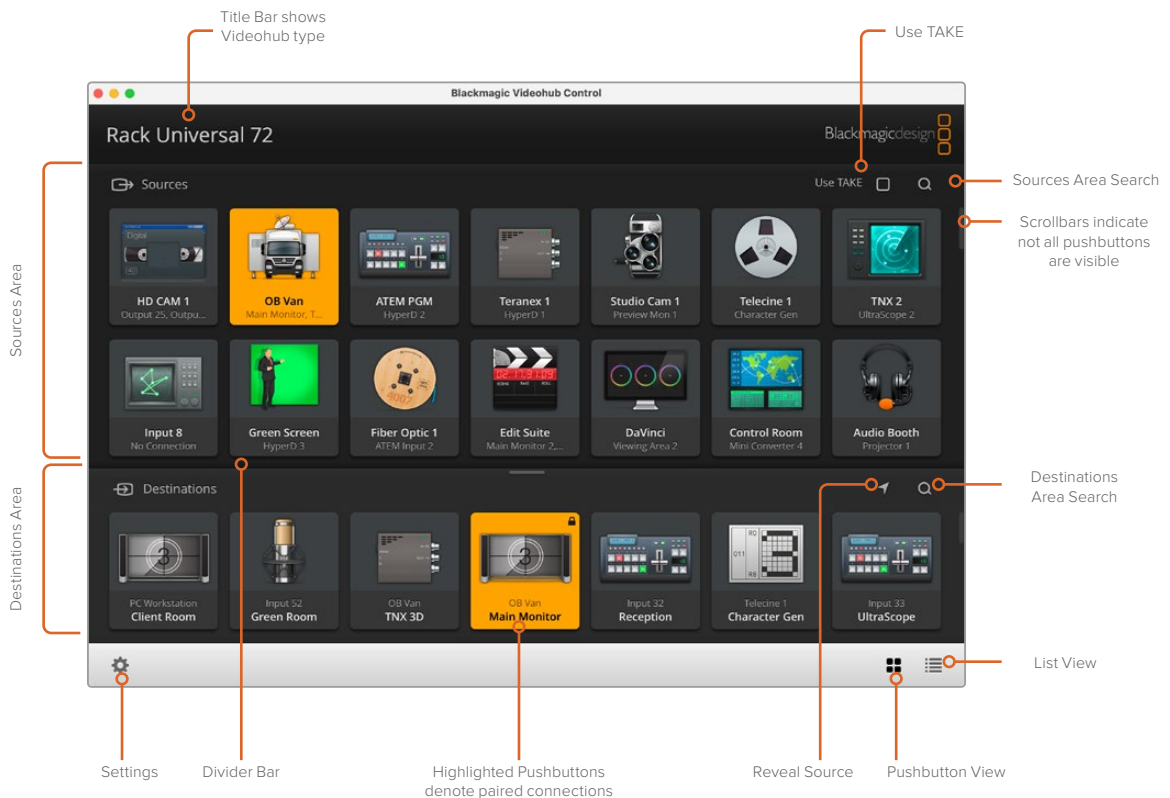







Click and drag the window edges to resize Blackmagic Videohub Control to fit your screen size. Drag the Divider Bar up or down to reveal more or less of the “Sources” and “Destinations” areas and use the Scroll Bars to scroll the areas.

### Settings Menu

<b>Select Videohub</b>		Select from a list of Videohubs that are currently connected to your network.
<b>Save Layout</b>		Save customized pushbutton layouts for the different environments in which you use your Videohub.
<b>Load Layout</b>		Load previously saved pushbutton layouts.
<b>Edit Buttons</b>		Displays the Edit Buttons for editing the pushbuttons.
<b>Reset All</b>		Displays all of the inputs and outputs of the connected Videohub and replaces customized icons with the default icon. Source, destination and deck control settings are maintained.

## Edit Buttons

<b>Add</b>		Add a source or destination pushbutton.
<b>Edit</b>		Allows you to set the SDI source or destination, deck control and the icon for the selected pushbutton.
<b>Lock and Unlock</b>		Lock a destination to avoid accidentally changing the video source which is routed to that destination. If you click on a pushbutton that's locked, the Lock button changes into an Unlock button. Simply click the Unlock button to unlock the destination pushbutton.
<b>Clear</b>		Deletes source, destination and deck control settings as well as the icon for the selected pushbutton.
<b>Remove</b>		Removes the selected pushbutton.
<b>Done</b>		Click the Done button to exit the edit mode.

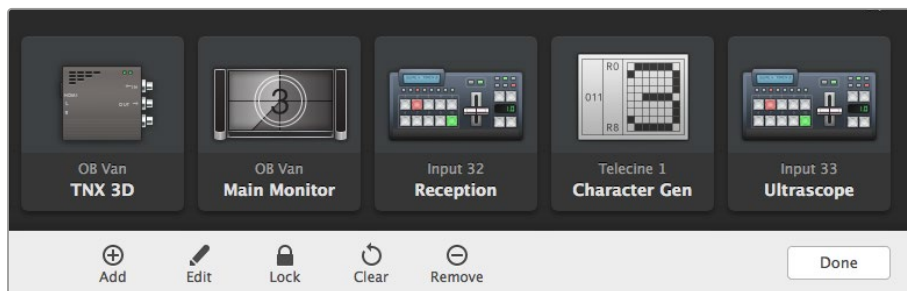

Click 'edit buttons' Buttons to choose a thumbnail image for a source or destination

## Using Pushbuttons

<b>Adding Pushbuttons</b>	<p>Select the Settings button and then select "Edit Buttons". Click on the Add button and choose whether to add a source or destination pushbutton.</p> <p>The Set Button window appears and allows you to set the SDI source or destination, RS-422 deck control and the icon for the pushbutton. In most cases, deck control is grouped with the associated SDI connections, e.g., SDI Input 1 would be associated with the corresponding Remote 1.</p>
<b>Editing Pushbuttons</b>	<p>Select "Edit Buttons" and click the pushbutton you wish to edit. Click on the Edit button and modify the source or destination, deck control settings and the icon as required.</p>

<p><b>Set Button</b></p>	<p>The Set Button window allows icon selection, source or destination selection and deck control configuration.</p> <div data-bbox="751 338 1059 898" style="text-align: center;"> </div>
<p><b>Moving Pushbuttons</b></p>	<p>Select the Settings button and then select “Edit Buttons”. Click and drag the pushbutton to a new position.</p>

## Viewing and Switching Routes

<p><b>Viewing Routes</b></p>	<p>In order to see which video source has been routed to a video destination, such as a monitor, press the button in the destinations panel to make the button illuminate. The associated video source button will illuminate in the sources panel, making it immediately obvious which source is connected to the monitor.</p>
<p><b>Reveal Source</b></p>	<p>If you select a destination but the source is currently positioned offscreen, clicking the Reveal Source button will scroll the Sources area to display the source pushbutton.</p>
<p><b>Switching Routes</b></p>	<p>Select the destination icon followed by the source icon.</p>

## Use TAKE Confirmation before Switching Routes

You may wish to enable the ‘use take’ feature to help prevent unintentional changes to video routes. Once enabled, any attempt to change a video route using a pushbutton will cause a red ‘take’ button to appear. Click the button to confirm or click the current source or destination pushbutton to cancel.

## Locking and Unlocking Routes

Locking a destination will avoid accidentally changing the video source which is routed to that destination. To lock a route, select the destination pushbutton and double click. A padlock icon will appear in the top-right corner of the destination pushbutton and will prevent anyone else from using the destination device until it is unlocked from your computer. Locking a destination still leaves the associated video source available for routing to multiple destinations simultaneously.

Double click the pushbutton to unlock the destination.

You can also lock one or multiple destinations via the edit buttons page. Shift click the destination pushbuttons you wish to lock and click the lock button. If you select a mixture of locked and unlocked pushbuttons, you will have the option to lock the unlocked pushbuttons.

Locking a route between an input and an output also locks the RS-422 deck control connection between the two devices to avoid other users accidentally seizing the deck control belonging to the video source. The RS-422 connection between the video source and video destination will remain locked until the destination pushbutton is unlocked.

**TIP** To toggle the lock status of a destination, simply double click the destination pushbutton.

A black padlock icon with a curved line above will appear on any destination pushbuttons locked by other Videohub devices. The video destination devices will not be available to you until the destination pushbuttons have been unlocked from the other users' computers and iPads.

If you need to unlock a route set by another user, launch Videohub Setup, select the Outputs tab and click the destination's lock icon.

**NOTE** It is important to note which routing level is selected, as it will affect the locking of routes. Universal Videohub consists of an SDI video level and an RS-422 deck control level. These levels can be switched together or can be separated for individual switching.

If you have selected SDI 422 on the level controls, it will lock both ports, however, if you select SDI or RS422 it will only lock the selected port. When the RS-422 port is locked you can still switch to SDI video, and when the SDI port is locked you can still switch to RS-422. This means that you can still route video signals even if the RS-422 port is locked, and still have deck control even if the SDI port is locked.

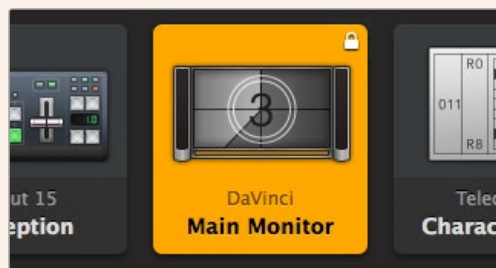

Locally locked destinations display a white padlock icon

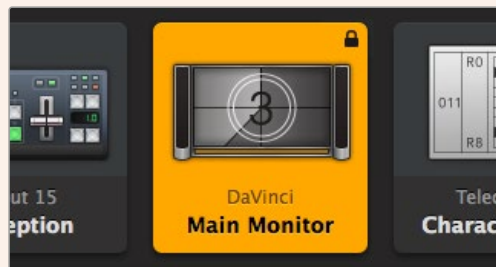

Remotely locked destinations display a black padlock icon

## Serial Control Settings

Third party router controllers can control Videohub with RS-422 serial connections.

If controlling Videohub via RS-422, set the 'Leitch protocol' switch to:

- 'Leitch client' if the Videohub is to act as a client of a connected control panel and to listen and respond to the control panel button presses.
- 'Leitch server' if the Videohub is to be controlled from an automation system or third party router control system.

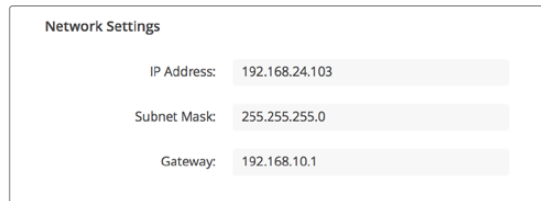

The screenshot shows a 'Network Settings' dialog box with three input fields. The first field is labeled 'IP Address' and contains the value '192.168.24.103'. The second field is labeled 'Subnet Mask' and contains the value '255.255.255.0'. The third field is labeled 'Gateway' and contains the value '192.168.10.1'.

The Videohub Server Configuration options will become active when a Videohub is connected via USB

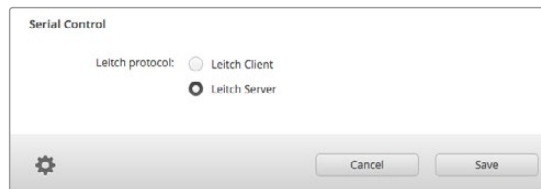

The screenshot shows a 'Serial Control' dialog box. It has a section labeled 'Leitch protocol:' with two radio button options: 'Leitch Client' (which is unselected) and 'Leitch Server' (which is selected). At the bottom of the dialog, there are three buttons: a gear icon on the left, a 'Cancel' button in the center, and a 'Save' button on the right.

Select either Client or Server when using RS-422 serial control

## Touchscreen Computers

Pushbutton View is designed to be easy to use and look beautiful on a large, touchscreen display. Dedicating a touchscreen computer to the Pushbutton View within the Videohub Control software makes it incredibly easy for users to switch connections between multiple SDI devices without having to see every connected device all of the time.

Using a touchscreen computer provides the fastest way to switch connections which is perfect for a master control room. Both desktop and laptop touchscreen computers can be used.

While touchscreens are perfect for rapidly selecting and routing inputs and outputs, they can be cumbersome for configuring pushbuttons. The width of a human fingertip is much wider than a mouse pointer and is less accurate when tapping on menu options and small icons.



For this reason, we recommend configuring the pushbuttons with a mouse. Once the Videohub pushbuttons have been configured, it will be easy to use a finger to select and route, inputs and outputs, by tapping on Videohub pushbuttons.

Touchscreens work a little differently to a computer mouse but provide the fastest and easiest way to work with the Videohub Control interface and so are highly recommended. When using a touchscreen computer, you can enable the Use Take option to help avoid unintentional routing changes.

## Apple iPad

The Videohub Pushbutton controller interface looks stunning on the high resolution Apple iPad display. Aside from looking great, it also provides the convenience of portable router control anywhere in your facility or even over the Internet via a wireless or cellular connection! If you are already familiar with the Videohub Pushbutton interface on a computer, then there is almost nothing new you need to learn and you'll only notice slight differences between computer mouse control and touchscreen control on the iPad. For information on how to download and install the application, refer to 'installing the Videohub Software on iPad' immediately after this section.



Up to 40 sources and 8 destinations can be displayed in a single Videohub Pushbutton screen on the iPad. Even more sources and destinations can be displayed by flicking the iPad left or right, or tapping to the left or right of the row of dots, to move through multiple Pushbutton screens.

### The initial Pushbutton interface

Upon launching the Videohub app on your iPad for the first time, all pushbuttons initially show the generic BNC connector icon, which you can then replace from a selection of icons. If the connections have not yet been labeled, then the source pushbuttons will appear as Input 1 to Input 40 and the destination pushbuttons will appear as Output 1 to Output 8.

If the connections have already been labeled, their names will appear under each of the respective pushbuttons in place of the connector numbers.

### Configuring Videohub Pushbuttons on the iPad

Configuring Videohub Pushbuttons on the iPad is easy. Press and hold any Videohub pushbutton to open the Videohub Button Setup window. This window allows you to set the SDI input or output connection, RS-422 deck control and the icon for the pushbutton.

The Clear button will delete all settings for the pushbutton. In most cases, deck control is grouped with the associated SDI connections, meaning an SDI connection named Input 1 would usually be associated with the corresponding Remote 1.

The bottom right source button is reserved by the Videohub app itself and cannot be configured. This is because if a destination pushbutton is connected to a source that does not appear in the sources panel, the source will automatically appear in the bottom right pushbutton.

When configuring pushbuttons, only select a deck control connection for those devices that have RS-422 deck control. It makes no sense to assign a deck control connection to a video monitor or camera.



The Videohub Button Setup window allows you to set the SDI input or output connection, RS-422 deck control and the icon for the pushbutton

While all icons are available to any pushbutton, it doesn't make sense to choose the icon of a video monitor or transmitter for a source pushbutton unless the source device happens to have a loop through output.

You may choose to show a particular source or destination pushbutton several times within the one Pushbutton screen or on multiple Pushbutton screens. If a destination pushbutton is routed from a source that appears multiple times in the Sources panel, selecting the destination pushbutton will illuminate all instances of the source pushbutton, regardless of how deck control has been configured for each source pushbutton. Similarly if multiple instances of an output pushbutton appear in the Destinations panel, they will illuminate together when any one has been selected.

### Viewing and Changing Routes

In order to see which video source has been routed to a particular destination, such as a monitor, press the monitor's pushbutton in the destinations panel. The monitor button and the associated video source button will simultaneously illuminate, making it immediately obvious which video source is connected to the video monitor, e.g., a HyperDeck Studio HD Pro.

In order to change the video source from a HyperDeck Studio HD Pro to a video camera, press a camera pushbutton in the sources panel to immediately illuminate the camera pushbutton and route video to the video monitor. The HyperDeck Studio HD Pro pushbutton will no longer be illuminated and will be disconnected from the video monitor.



In order to see which video source has been routed to a video destination, tap a destination button and the associated video source button will illuminate

### Locking and Unlocking Routes

Locking a destination avoids accidental changes of the video source being routed to that destination. To lock a route between an input and an output, double-tap the destination pushbutton. A yellow padlock icon will appear in the top left corner of the destination pushbutton and will prevent anyone else from using the destination device until it is unlocked from your iPad. Double tap the destination pushbutton again to unlock. Locking a destination still leaves the associated video source available for routing to multiple destinations simultaneously.

Locking a route between an input and an output also locks the RS-422 deck control connection between the two devices. This is to avoid other users accidentally seizing the deck control belonging to the video source.

The RS-422 connection between the video source and video destination will remain locked until the destination pushbutton is unlocked.

A gray padlock icon will appear on any destination pushbuttons that other users have locked. The video destination devices will not be available to you until the destination pushbuttons have been unlocked from the other users' computers and iPads.

If you encounter a gray padlock icon and do not know who locked the video device you can override the lock using the Videohub software on a Mac or Windows computer. When a route is unlocked, the padlock icon will disappear.



A yellow padlock icon will appear in the top-left corner of the destination pushbutton and will prevent anyone else from using the destination device until it is unlocked from your iPad. A gray padlock icon will appear on any destination pushbuttons that other users have locked.

## Installing the Videohub Software on iPad

The Videohub software for iPad can be downloaded using your Apple ID account.

To download the Videohub iPad software through your iPad:

- 1 Tap the 'app store' icon.
- 2 Tap the 'search' field at the top of the screen and enter 'Blackmagic Videohub'.
- 3 Tap on the 'get' button next to the 'Blackmagic Videohub app' icon and tap 'install'.

Setting up the IP address in Videohub for iPad:

- 1 Tap the 'settings' icon.
- 2 In the 'apps' section, select 'Videohub' and enter your Videohub IP address in the 'Videohub IP address' field.
- 3 You can now start using your Videohub software by tapping on the Videohub icon on the 'home' screen.

For more information on controlling your Videohub using iPad, see the 'Apple iPad' section in this manual.

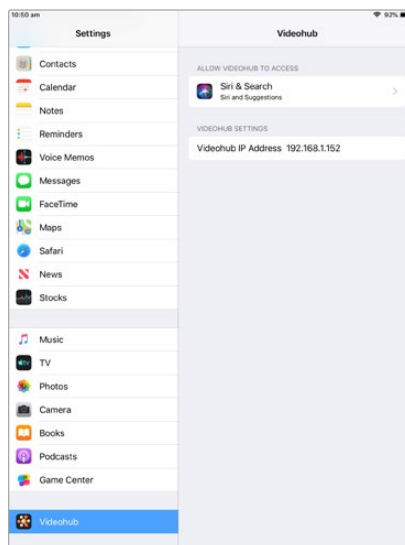
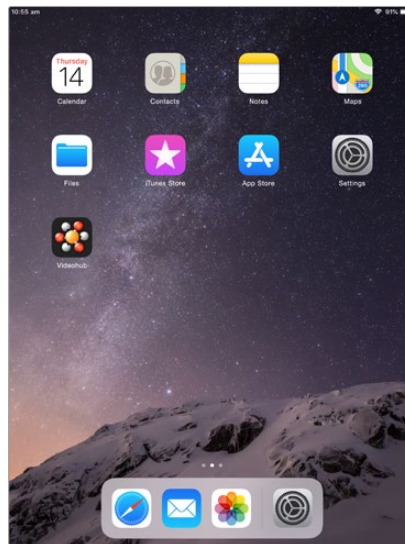

Videohub settings on iPad

# Videohub Hardware Panel Setup

When you launch Blackmagic Videohub Hardware Panel Setup, any Videohub control panels discovered on the network will be listed in the Videohub Control Panels pane next to an Ethernet network icon. If several Videohub control panels are listed, but you don't know which one is which, select one of them and then press Identify. This will cause all the buttons of the selected Videohub control panel to flash white.

Select the desired Videohub control panel and you will be able to change its name and control settings. Network settings will remain grayed out and can only be changed via USB.

If the desired Videohub control panel is not found on the network, the unit might not have received an IP address via DHCP. To manually configure the unit with appropriate network settings:

- 1 Connect the Videohub control panel to your computer via a USB cable.
- 2 Launch Blackmagic Videohub Hardware Panel Setup. If the utility prompts you to update the software, follow the prompts to complete the update.
- 3 The USB connected panel will be automatically selected in the Videohub Control Panels pane and will display a USB icon next to its name. You can change all name, network and control settings for the USB connected unit. When you are finished, the USB cable can be removed.

If your Videohub control panel is selected in the control utility, the pushbuttons on the unit will light up to match what is displayed in the software interface.

## Network Settings

Each Videohub control panel requires an IP address to communicate with Videohub via your IP network.

When configuring a Videohub control panel via USB, you can choose DHCP or Static IP. DHCP automatically obtains all the network settings for your Videohub control panel and is the easier choice.

If you decide to use a static IP address, please ask your system administrator for a spare IP address to avoid creating a conflict on your network. You will then need to complete the IP address, subnet mask and gateway details for your Videohub control panel. You must use a static IP address if you are connecting directly to a Videohub without using a network switch.

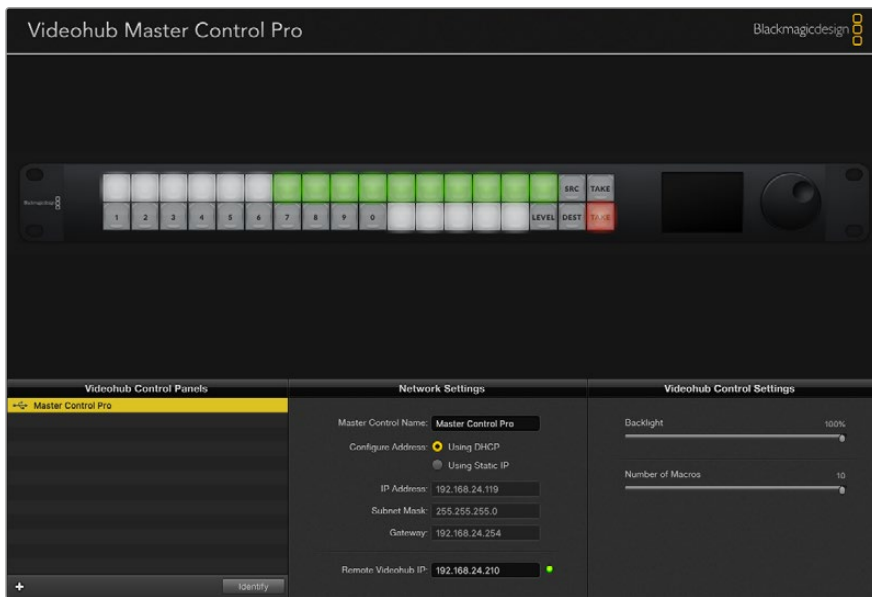

The Blackmagic Videohub Hardware Panel Setup automatically searches your network for any Videohub control panels

You will also need to complete the IP details for the remote Videohub that you wish to control with your Videohub control panel. The remote Videohub is the Videohub Server. This could refer to a Videohub Server computer or an integrated Videohub Server onboard a Videohub model such as Blackmagic Videohub 12G 80x80.



Any Ethernet or USB connected control units will be listed in the Videohub Control Panels pane with a corresponding icon

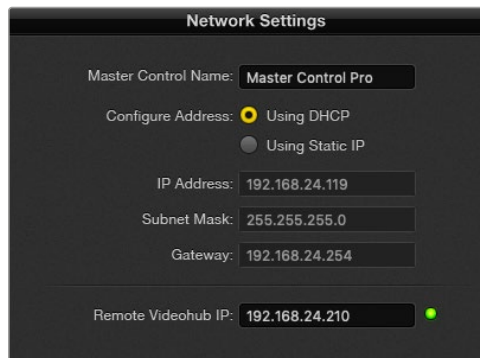

Blackmagic Videohub Hardware Panel Setup network settings

If you are setting up hardware panel control for an IP Videohub, enter the host computer's IP address in the 'remote Videohub IP' setting field. The Videohub server shares the same IP address with the host computer.

### Add Videohub Control

If you already know the IP address of a Videohub control panel but it hasn't automatically appeared in the Videohub Control Panels pane, you can add the unit manually.

- 1 Press the + (add device) button at the bottom of the Videohub Control Panels pane.
- 2 Type in the IP address of the Videohub Control Panel and press OK.
- 3 The Videohub Control Panel will appear in the list with any other devices that are connected to the Videohub.

If the Blackmagic Videohub Hardware Panel Setup does not find a Videohub control panel at the specified address, you can use the Utility to manually add a Videohub control panel when connected via Ethernet or USB.



You can manually add a Videohub control panel, by IP address, to the list of Videohub Control Panels

### Load/Save Settings

You can apply settings from an already configured Videohub control panel to other units.

Once you have set up your Videohub Control Panel's settings, choose File>Save Settings. This is useful if you want to set up several units the same way, or keep a back up of your settings.

After loading preconfigured settings on another control panel, you only need to update network settings, including the control panel name.

## Configuring Videohub Master Control Pro

Videohub Hardware Panel Setup software lets you customize the hardware features of each Videohub control panel.

### Backlight

Adjust the backlight slider as desired to vary the brightness of all backlit buttons.



You can adjust the brightness of all backlit buttons in Videohub Master Control

## Creating Button Labels

21 of the buttons can be labeled within the control utility to provide fast selection of common equipment types such as cameras, VTRs and monitors. Any of these 21 buttons can also be configured as macro buttons.

If you haven't done so already, you should standardize the port labels on your Videohub router before labeling any buttons on your Videohub control unit.

Please refer to the 'labeling pushbuttons' section for detailed information on customizing your labels.

You are now ready to label the Videohub Master Control Pro buttons.

- 1 Launch the Videohub Hardware Panel Setup and select your Videohub Master Control Pro from the Panels pane.
- 2 Click one of the 21 buttons in the picture of the panel. Enter a text label so it partially matches the labels of SDI and deck control ports that you previously entered for your router.
- 3 Click OK and continue labeling the other buttons as desired.
- 4 You can immediately test the buttons as you program them and verify the SDI routes are valid.

Refer to the 'labeling pushbuttons' section for instructions on how to label the physical pushbuttons.



Click on the desired button to edit its label

## Configuring Videohub Smart Control Pro

Videohub Hardware Panel Setup lets you customize the hardware features of each Videohub control panel.

### Number of Destinations

Videohub Smart Control can be configured as a cut bus controller or as an XY controller. When configured as a cut bus controller, every button represents an SDI source and there is only one destination.

When configured as an XY controller, Videohub Smart Control Pro can work with up to 24 destinations. The source buttons will illuminate white and the destination buttons will illuminate gold. Use this configuration if you don't intend to dedicate a Videohub Smart Control Pro unit to each destination device.

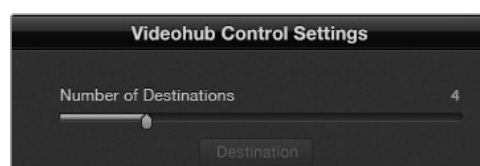

Videohub Smart Control Pro configured with multiple destinations

## Cut Bus Configuration

- 1 Drag the Number of Destinations slider to 1.
- 2 Click on the Destination button. In the Router SDI Out A field, enter the number of the Videohub output port to which the destination device is connected. If your destination device requires dual link SDI, you will need to enter an output port number in the Router SDI Out A & B fields. For quad link SDI, you will need to enter numbers in all four 'out' fields. There is a Router Remote field if your Videohub is also routing RS-422 deck control to the destination device.
- 3 Click OK to confirm. All the buttons will become white, indicating that they are all sources.
- 4 Click on each white button in the software interface to configure the source buttons.
- 5 In the Router SDI In A field, enter the number of the Videohub input port to which the source device is connected. For dual link SDI destinations you will need to enter port numbers for fields A and B, or fields A through D for quad link SDI. There is a Router Remote field if your Videohub is also routing RS-422 deck control from the source device.
- 6 Click OK to confirm.

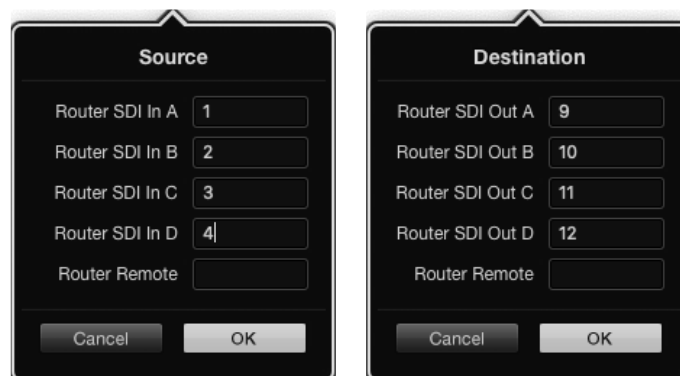

Add a port number for all SDI fields when using quad link SDI destinations

## XY Controller Configuration

- 1 Drag the Number of Destinations slider to the desired number.
- 2 You can now configure the destination buttons by clicking on each gold button in the software interface. In the Router SDI Out A field, enter the number of the Videohub output port to which the destination device is connected. For dual link SDI destinations you will need to enter port numbers for fields A and B, or fields A through D for quad link SDI. There is also a Router Remote field if your Videohub is also routing RS-422 deck control to the destination device.
- 3 Click OK to confirm. If you increase the number of destination buttons, there will be a matching decrease in the number of available source buttons.
- 4 Click on each white button in the software interface to configure the source buttons.
- 5 In the Router SDI In A field, enter the number of the Videohub input port to which the source device is connected. For dual link SDI destinations you will need to enter port numbers for fields A and B, or fields A through D for quad link SDI. There is also a Router Remote field if your Videohub is also routing RS-422 deck control from the source device.
- 6 Click OK to confirm.

## Number of Macros

Macros allow you to make up to 16 crosspoint routing changes simultaneously with a single button press.

- 1 Drag the Number of Macros slider to enable up to 10 macro buttons. As you increase the number of macro buttons, there will be a matching decrease in the number of available source buttons.
- 2 Click a green macro button to reveal the corresponding Macro window and enter up to 16 pairs of sources and destinations.
- 3 When finished, click OK to save the routes and close the window.

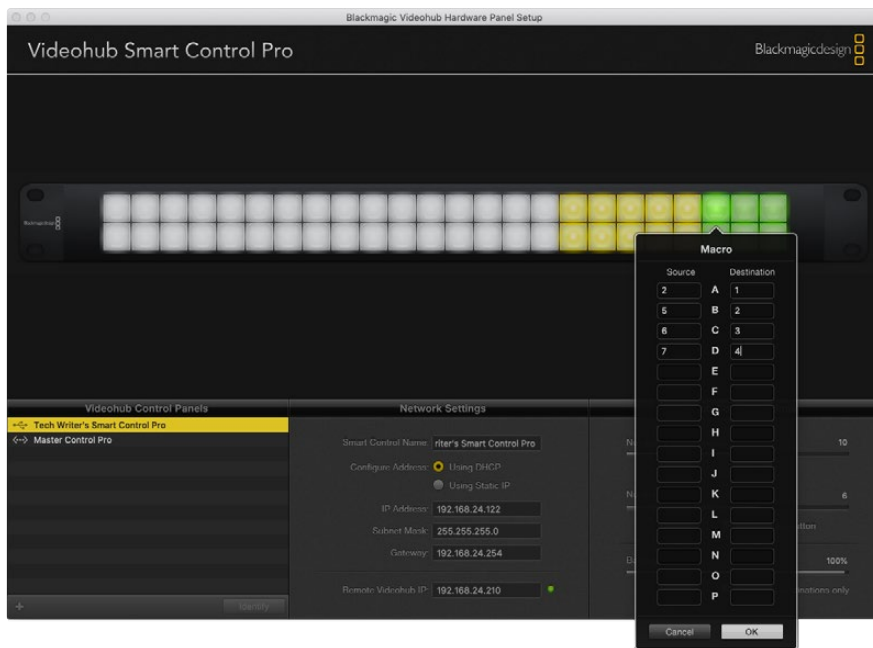

Up to 16 crosspoint routes can be changed by a single macro

## Take Button

When the Enable Take Button checkbox is active, the lower right button on the control interface turns red. Use this if you want a confirmation option to come up before your route change takes place. Press the red take button to confirm your route change. The take button can be used with both Cut-Bus and XY controller configurations and can also be used with macros.

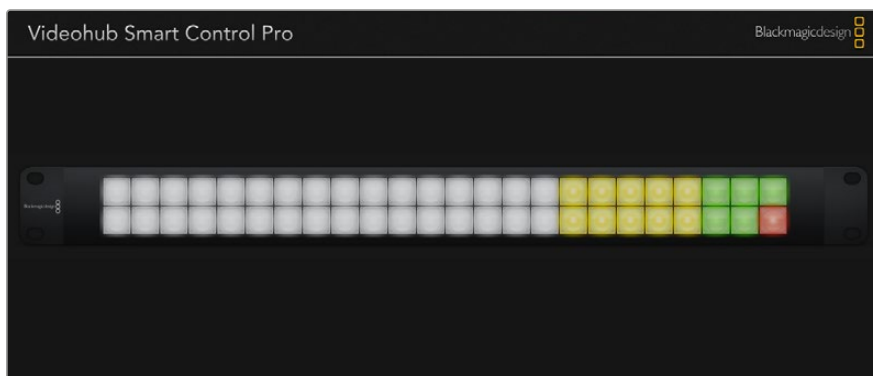

The Take button illuminates red in the lower right corner

## Backlight

Adjust the backlight slider to vary the brightness of the backlit buttons as desired. Enable Backlight Destinations Only if you wish to disable the backlighting of the white source buttons.

## Configuring GPIs

The GPI and Tally Interface has 8 GPIs that provide crosspoint switching. In the example on the left, if GPI 1 detects a contact closure it will switch Input 12 on your Videohub to Output 1. This means when you switch the joystick control on your CCU, video going to Input 12 of your Videohub will be previewed on your monitor.

The crosspoints can be configured in the Videohub Hardware Panel Setup simply by clicking inside the Input and Output fields on the diagram and typing in the Input or Output number.

The Videohub Control Settings pane offers two ways to preview the output from your Videohub.

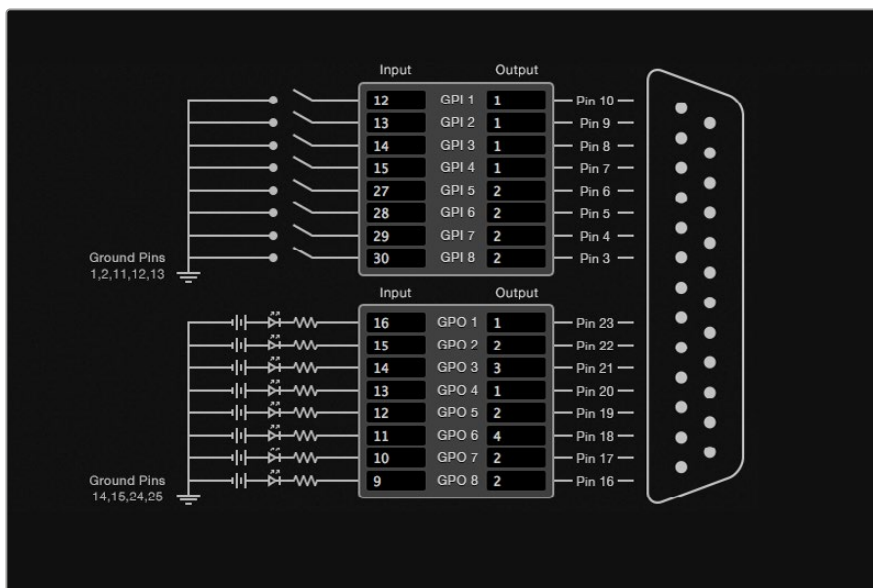

Click inside the diagram to change inputs and outputs for GPI crosspoint switching and Tally

## Latch Video

If you want the output to stay as selected, choose Latch Video. This means you can press the switch once on your CCU and the input from the selected crosspoint will stay on your monitor until another crosspoint is selected.

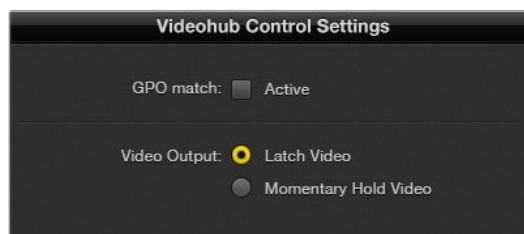

Select Latch Video if you want your preview to hold until another crosspoint is selected. Choose Momentary Hold Video if you want your preview to revert back to the previous crosspoint when you release the control switch.

## Momentary Hold Video

Select this option if you want the output to return to the previous input after you let go of the switch or joystick control on your CCU. For example, when you press and hold your switch, Input 13 might be previewed, but will return to displaying Input 12 on your monitor once you release the switch.

## Configuring Tally

Tally is usually a lamp on the front of a camera to indicate that it is on air, but it's a useful visual indicator and can be used on any equipment to indicate activity and doesn't have to be used specifically with cameras.

The GPI and Tally Interface has 8 configurable GPOs, which send a tally signal to your cameras or other devices under certain crosspoint conditions. In the example on the left, GPO 1 is configured so that when Input 16 on the Videohub is routed to Output 1, GPO 1 will be activated.

The crosspoints can be configured in Videohub Hardware Panel Setup simply by clicking inside the Input and Output fields on the diagram.

## GPO Match

Enable the GPO match checkbox to replicate the configuration of your crosspoints from GPIs to GPOs. This can be useful if you want to see a tally light activate when changing routes for your GPIs.

When this checkbox is enabled, the GPO half of the diagram will be grayed out and cannot be edited until the GPO match checkbox is disabled.

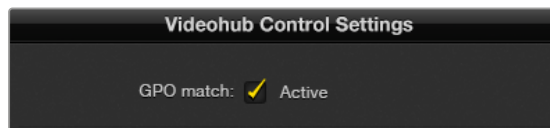

Enable the GPO match checkbox to replicate the crosspoint configuration of your GPIs

## Daisy Chaining Multiple GPI and Tally Interfaces

The GPI and Tally Interface supports 8 GPIs and 8 GPOs at a time, which should be enough for most live television situations. However, if you have more than 8 cameras then you may want to daisy chain a second or third GPI and Tally Interface.

The GPI and Tally Interface has two Ethernet ports so that you can connect one port to a Videohub and use the other port to link other GPI and Tally Interfaces together.

- 1 Connect power to the first GPI and Tally Interface.
- 2 Connect a standard RJ45 Ethernet cable from your Videohub or network to the Ethernet IN port on the GPI and Tally Interface.
- 3 Connect power to the second GPI and Tally Interface.
- 4 Connect a standard RJ45 Ethernet cable from the Ethernet OUT of the first GPI and Tally Interface to the Ethernet IN port on the second GPI and Tally Interface.

This can be repeated for as many GPI and Tally Interfaces as you need as long as power is supplied to all units in the chain.

Sometimes it can get confusing to know which GPI and Tally Interface you are working with when you have several connected. Select the GPI and Tally Interface in the Videohub Control

Panels pane and click the Identify button. The LED next to the Ethernet IN port on the selected device will light up.

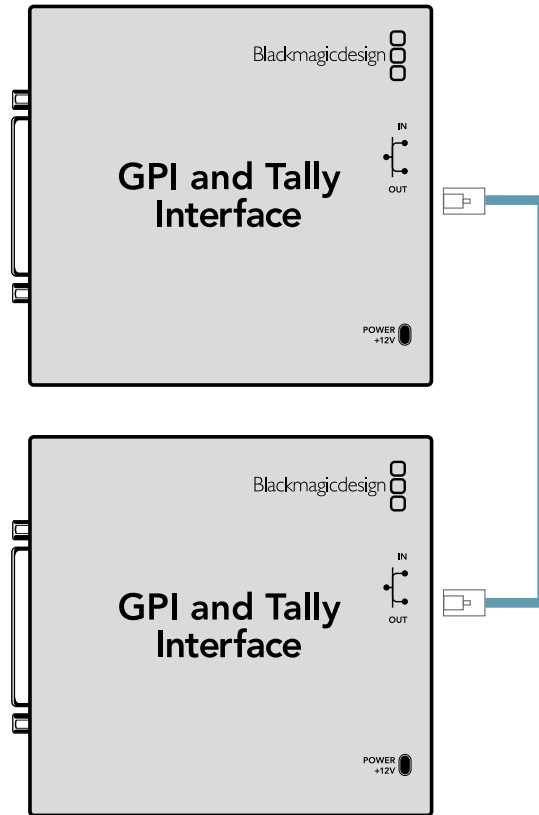

Daisy chain multiple GPI and Tally Interfaces using Ethernet. Power must be supplied to each individual unit in the chain.

## Adding a GPI and Tally Interface Over a Network

You may want to configure a second GPI and Tally Interface but it may be in another location and only accessible over a network. You can add it to your list manually by entering its IP address into Videohub Hardware Panel Setup.

If you do not know the IP address of the GPI and Tally Interface you want to add, connect it to a computer with USB, open Videohub Hardware Panel Setup and note down the IP address in the Network Settings tab.

If you do not have access to the unit because it is in another location, you can find it on the network using the Bonjour browser. This application will show you all the devices on your network and will give you the IP address of the GPI and Tally Interface you wish to add.

- 1 Press the + (add device) button at the bottom of the Videohub Control Panels pane.
- 2 Type in the IP address of the GPI and Tally Interface and press OK.
- 3 The second GPI and Tally Interface will appear in the list with any other devices that are connected to the Videohub.

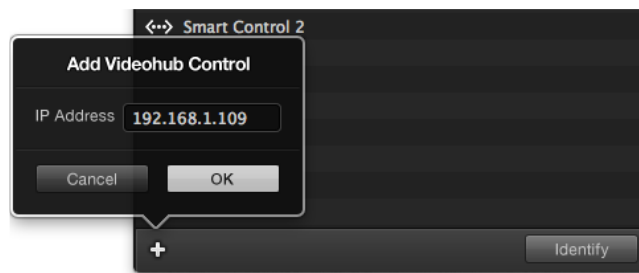

Press the + (add device) button and enter the IP address of a GPI and Tally Device you want to add. Press the Identify button to activate the LED on a selected GPI and Tally Interface.

## Setting up the GPI and Tally Interface

The GPI and Tally Interface is configured using the Videohub Hardware Panel Setup. Before you can use the GPI and Tally Interface, you may need to install the latest version of the software.

- 1 Connect the power adapter to the GPI and Tally Interface.
- 2 Connect the GPI and Tally Interface to your computer with a USB Type A to B cable.
- 3 Open the software and it will detect whether your GPI and Tally Interface has been configured for a Videohub before. If it has the software will open without any need for changes. Otherwise a message will tell you your GPI and Tally Interface has been configured for use with an ATEM Switcher and will need to be reconfigured for use with Videohub. Click Yes. After a few moments the GPI and Tally Interface will be reconfigured as a Videohub client.

## Configuring the GPI and Tally Interface

If your Videohub does not have an Ethernet port, or if it is only accessible over a network:

- 1 Connect a USB type A to B cable from your GPI and Tally Interface to your computer.
- 2 Connect an Ethernet cable from the Ethernet IN port on your GPI and Tally Interface to your Ethernet switcher.
- 3 Open Videohub Hardware Panel Setup.
- 4 You should see your GPI and Tally Interface with a USB icon next to it in the Videohub Control Panels pane. Give your GPI and Tally Interface a unique name so it can be easily recognized. To do so, click inside the GPI and Tally Name field and type a name.
- 5 Check the option to configure your IP address as 'using DHCP' or 'static IP'. Depending on your setup, you may choose either so it's probably a good idea to check with your network administrator to see which is the better option.
- 6 In the Remote Videohub IP field, enter the IP address of the Videohub you want to connect to. A red light next to the field will turn green and the LED on the GPI and Tally interface will illuminate when a connection has been established.

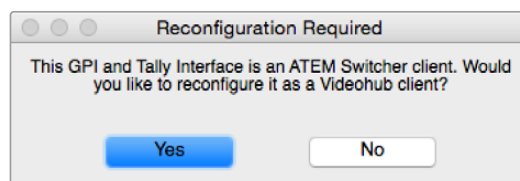

You will need to reconfigure your GPI and Tally Interface to work with Videohub

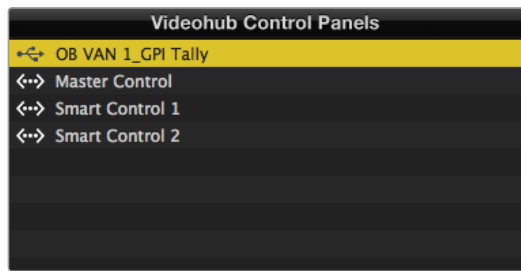

GPI and Tally Interface connected via USB

If you do not know the IP address of your Videohub:

- 1 Connect the Videohub to your computer via USB.
- 2 Launch the Videohub software and click on Videohub Server Preferences.
- 3 Note down the IP address in the Remote Videohub IP address field.

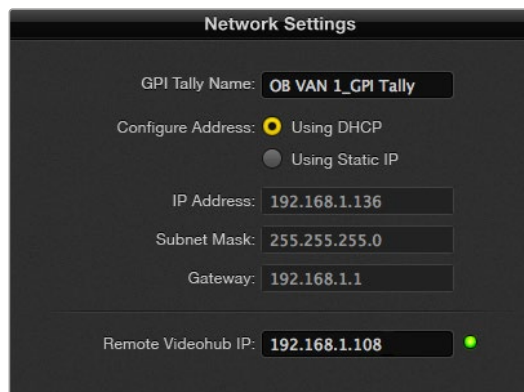

Enter a GPI and Tally Name and the IP address of the Videohub you want to connect to

# Developer Information

## Blackmagic Videohub Ethernet Protocol v2.8

### Summary

The Blackmagic Videohub Ethernet Protocol is a text based protocol that is accessed by connecting to TCP port 9990 on a Videohub Server. Integrated Videohub Servers and Videohub Server computers are supported by the protocol.

The Videohub Server sends information in blocks which each have an identifying header in all-caps, followed by a full-colon. A block spans multiple lines and is terminated by a blank line. Each line in the protocol is terminated by a newline character.

Upon connection, the Videohub Server sends a complete dump of the state of the device. After the initial status dump, status updates are sent every time the Videohub status changes.

To be resilient to future protocol changes, clients should ignore blocks they do not recognize, up to the trailing blank line. Within existing blocks, clients should ignore lines they do not recognize.

#### LEGEND

↵ line feed or carriage return  
... and so on

### Protocol Preamble

The first block sent by the Videohub Server is always the protocol preamble:

```
PROTOCOL PREAMBLE:↵  
Version: {Version}↵  
↵
```

The version field indicates the protocol version. When the protocol is changed in a compatible way, the minor version number will be updated. If incompatible changes are made, the major version number will be updated.

### Device Information

The next block contains general information about the connected Videohub device. If a device is connected, the Videohub Server will report the attributes of the Videohub:

```
VIDEOHUB DEVICE:↵  
Device present: {"true", "false"}↵  
Model name: {Model Name}↵  
Friendly name: {Friendly Model Name}↵  
Unique ID: {Unique device ID}↵  
Video inputs: {n}↵  
Video outputs: {n}↵  
↵
```

This example is for the Blackmagic Videohub 10x10 12G:

```
VIDEOHUB DEVICE:↵  
Device present: true↵  
Model name: Blackmagic Videohub 10x10 12G↵  
Friendly name: Blackmagic Videohub 10x10 12G↵  
Unique ID: A654D3524FD4493FAB12105BACF1299F↵  
Video inputs: 10↵  
Video outputs: 10↵  
↵
```

If the Videohub Server has no device connected, the block will simply be:

```
VIDEOHUB DEVICE:↵  
Device present: false↵  
↵
```

If a device is present, but has an incompatible firmware, the status reported will be:

```
VIDEOHUB DEVICE:↵  
Device present: needs _ update↵  
↵
```

In the last two situations, no further information will be sent, unless the situation is rectified.

If the Videohub Server detects a new Videohub attached, it will resend all blocks except the protocol preamble to indicate the device has changed, and allow the client to update its cache of server state.

## Network Information

```
NETWORK:↵  
Interface Count: {1}↵  
Default Interface: {0}↵  
↵  
  
NETWORK INTERFACE:↵  
Name: {n} GbE↵  
Priority: {1}↵  
MAC Address: {Device MAC Address}↵  
Dynamic IP: {"true", "false"}↵  
Current Addresses: {ip address/subnet mask}↵  
Current Gateway: {Current Gateway address}↵  
Static Addresses: {Static IP Addresses}↵  
Static Gateway: {Static Gateway}↵  
↵
```

## Initial Status Dump

The next two blocks enumerate the input and output labels.

Videohubs that do not have monitoring or serial ports do not send the corresponding blocks.

```
INPUT LABELS:↵
0 Input 1↵
1 Input 2↵
...
↵
OUTPUT LABELS:↵
0 Output 1↵
1 Output 2↵
...
↵
```

**NOTE** Ports are always numbered starting at zero in the protocol which matches port one on the chassis.

The next block describes the locking status of the output. Each port has a lock status of "O" for ports that are owned by the current client (i.e., locked from the same IP address), "L" for ports that are locked from a different client, or "U" for unlocked.

```
VIDEO OUTPUT LOCKS:↵
0 U↵
1 U↵
...
↵
```

The next block describes the routing of the output.

```
VIDEO OUTPUT ROUTING:↵
0 5↵
1 3↵
...
↵
```

## Status Updates

When any route, label, or lock is changed on the Videohub by any client, the Videohub resends the applicable status block, containing only the items that have changed. For example, if video output lock 6 has been unlocked, the following block will be sent:

```
VIDEO OUTPUT LOCKS:↵
5 U↵
↵
```

If multiple items are changed, multiple items may be present in the update:

```
OUTPUT LABELS:↵
```

```
7 New output 8 label↵
10 New output 11 label↵
↵
```

If a card is plugged into or removed from the Universal Videohub, it will send hardware status blocks for the video inputs, video outputs, and serial ports on that card.

### Requesting Changes

To update a label, lock or route, the client should send a block of the same form the Videohub Server sends when its status changes. For example, to change the route of output port 8 to input port 3, the client should send the following block:

```
VIDEO OUTPUT ROUTING:↵
7 2↵
↵
```

The block must be terminated by a blank line. On receipt of a blank line, the Videohub Server will either acknowledge the request by responding:

```
ACK↵
↵
```

or indicate that the request was not understood by responding:

```
NAK↵
↵
```

After a positive response, the client should expect to see a status update from the Videohub Server showing the status change. This is likely to be the same as the command that was sent, but if the request could not be performed, or other changes were made simultaneously by other clients, there may be more updates in the block, or more blocks. Simultaneous updates could cancel each other out, leading to a response that is different to that expected.

In the absence of simultaneous updates, the dialog expected for a simple label change is as follows:

```
OUTPUT LABELS:↵
6 new output label seven↵
↵
ACK↵
↵
OUTPUT LABELS:↵
6 new output label seven↵
↵
```

The asynchronous nature of the responses means that a client should never rely on the desired update actually occurring and must simply watch for status updates from the Videohub Server and use only these to update its local representation of the server state.

To lock an output, send an update to the port with the character "O" indicating that you wish to lock the port for example:

```
VIDEO OUTPUT LOCKS:↵
7 O↵
↵
ACK↵
↵
```

```
VIDEO OUTPUT LOCKS:↵
7 O↵
↵
```

To forcibly unlock a port that has been locked by another client, send an update to the port with the character “F” instead of using the usual unlock character “U”. For example, to override a lock on port 7:

```
VIDEO OUTPUT LOCKS:↵
7 F↵
↵
ACK↵
↵
VIDEO OUTPUT LOCKS:↵
7 U↵
↵
```

Hardware status blocks can only be sent by the Videohub Server. If a client sends hardware status blocks, they will be ignored.

### Requesting a Status Dump

The client may request that the Videohub Server resend the complete state of any status block by sending the header of the block, followed by a blank line. In the following example, the client requests the Videohub Server resend the output labels:

```
OUTPUT LABELS:↵
↵
ACK↵
↵
OUTPUT LABELS:↵
0 output label 1↵
1 output label 2↵
2 output label 3↵
...
↵
```

### Checking the Connection

While the connection to the Videohub Server is established, a client may send a special no-operation command to check that the Videohub Server is still responding:

```
PING:↵
↵
```

If the Videohub Server is responding, it will respond with an ACK message as for any other recognized command.

## Take Mode

The next block describes the take mode status of the output.

```
CONFIGURATION:↵  
Take Mode: {'true','false'}↵
```

If the Videohub outputs are all set to take on, the status reported will be:

```
TAKE MODE:↵  
0 true↵  
1 true↵  
...  
END PRELUDE:↵
```

If the Videohub outputs are set to a mix of take on and take off, the status reported will be:

```
TAKE MODE:↵  
0 true↵  
1 false↵  
2 true↵  
3 false↵  
4 true↵  
...  
END PRELUDE:↵
```

## Saving and Loading Labels with Terminal in Mac OS

Normally you would use Blackmagic Videohub Setup to save and load labels between different Videohub routers and to backup your videohub settings. However, if for any reason you wish to use the Videohub Ethernet Protocol, the instructions below let you save, edit and load router label configurations using a command line program on your computer, such as Terminal.

```
[PROTOCOL PREAMBLE: ]  
[Version: 2.8 ]  
  
VIDEOHUB DEVICE:  
Device present: true  
Model name: Blackmagic Videohub 10x10 12G  
Friendly name: Blackmagic Videohub 10x10 12G  
Unique ID: A654D3524FD4493FAB12105BACF1299F  
Video inputs: 10  
Video outputs: 10  
  
NETWORK:  
Interface Count: 1  
Default Interface: 0  
  
NETWORK INTERFACE 0:  
Name: 1GbE  
Priority: 1  
MAC Address: 7c:2e:0d:06:bb:97  
Dynamic IP: true  
Current Addresses: 10.61.211.50/255.255.255.0  
Current Gateway: 10.61.211.1  
Static Addresses: 10.0.0.2/255.255.255.0  
Static Gateway: 10.0.0.1  
  
INPUT LABELS:  
0 CAM 1  
1 CAM 2  
2 CAM 3  
3 CAM 4  
4 CAM 5  
5 CAM 6  
6 CAM 7  
7 CAM 8  
8 CAM 9  
9 CAM 10
```

Changing labels using a Mac:

- 1 Open the Terminal application which is located within the Applications > Utilities folder.
- 2 Type in “nc” and a space followed by the IP of your Videohub, then another space and “9990”, which is the default port number. For example type: nc 192.168.25.253 9990. The Protocol Preamble screen will appear.
- 3 Copy the INPUT LABELS: text including the heading and paste into a word processor or simple text editor. You can save this now or copy and paste the output labels to the same document. Once copied, you can modify the label name by replacing the current name with a label of your choice. Once you’ve made the changes, save the file to your favorite location.
- 4 Close the telnet session by exiting the terminal window.

### Loading Labels

- 1 Open the Terminal application which is located within the Applications > Utilities folder.
- 2 Type in “nc” and a space followed by the IP of your Videohub, then another space and “9990”, which is the default port number. For example type: nc 192.168.25.253 9990. The Protocol Preamble screen will appear.
- 3 Open the the labels files you’ve previously saved in your text editor. Highlight from INPUT LABELS: through to the last label and copy.
- 4 Paste this into the terminal window and press “return” twice. Telnet will respond with “ACK” and Videohub will update the input labels.
- 5 Repeat with the saved output labels.
- 6 Close the telnet session by exiting the terminal window.

## Saving and Loading Labels with PuTTY in Windows

While you can save and load labels within Blackmagic Videohub Setup, you may also download and use PuTTY which is a free telnet client.

### Setting up PuTTY

- 1 Start the application and in the “Host Name” field, type the IP of your Videohub and in the “Port” field type “9990”, which is the default port number.
- 2 From the Connection type options select the “Telnet” radio button.
- 3 Select the “Terminal” tab and tick the “Implicit CR in every LF” checkbox.
- 4 Click the “Session” tab and save your session parameters by entering a name in the “Saved Sessions” field and clicking the “Save” button.

### Saving Labels

- 1 Double click the PuTTY icon to start the application. Select your saved session from the list and click the “Load” button followed by the “Open” button. The Protocol Preamble screen will appear.
- 2 Copy the INPUT LABELS: text including the heading and paste into a word processor or simple text editor. Name this file “input labels” and save to your favorite location.
- 3 Copy the OUTPUT LABELS: text including the heading and paste into a word processor or simple text editor. Name this file “output labels” and save to your favorite location.
- 4 Exit the telnet session by closing the PuTTY window.

## Loading Labels

- 1 Double click the PuTTY icon to start the application. Select your saved session from the list and click the “Load” button followed by the “Open” button. The Protocol Preamble screen will appear.
- 2 Open the “input labels” text file in your text editing program and copy the INPUT LABELS: text.
- 3 Right click in the PuTTY session to paste the copied section and press “Enter” twice. PuTTY will respond with “ACK” and Videohub will update the input labels.
- 4 Open the “output labels” text file in your text editing program and copy the OUTPUT LABELS: text.
- 5 Right click in the PuTTY session to paste the copied section and press “Enter” twice. PuTTY will respond with “ACK” and Videohub will update the output labels.
- 6 Exit the telnet session by closing the PuTTY window.

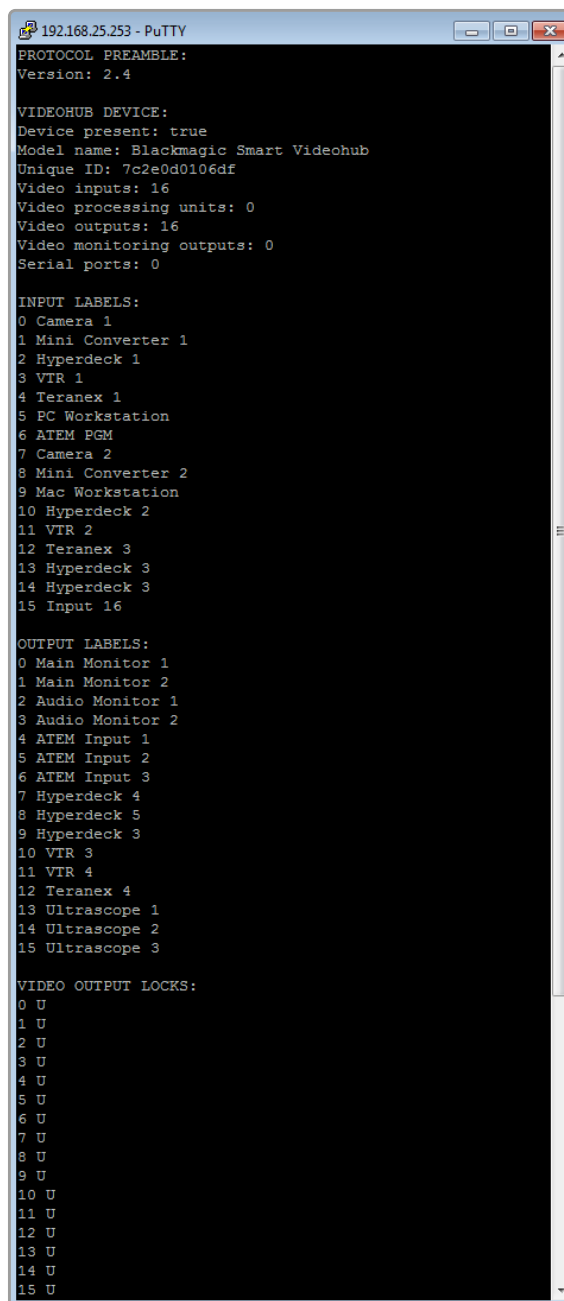

```
192.168.25.253 - PuTTY
PROTOCOL PREAMBLE:
Version: 2.4

VIDEOHUB DEVICE:
Device present: true
Model name: Blackmagic Smart Videohub
Unique ID: 7c2e0d0106df
Video inputs: 16
Video processing units: 0
Video outputs: 16
Video monitoring outputs: 0
Serial ports: 0

INPUT LABELS:
0 Camera 1
1 Mini Converter 1
2 Hyperdeck 1
3 VTR 1
4 Teranex 1
5 PC Workstation
6 ATEM PGM
7 Camera 2
8 Mini Converter 2
9 Mac Workstation
10 Hyperdeck 2
11 VTR 2
12 Teranex 3
13 Hyperdeck 3
14 Hyperdeck 3
15 Input 16

OUTPUT LABELS:
0 Main Monitor 1
1 Main Monitor 2
2 Audio Monitor 1
3 Audio Monitor 2
4 ATEM Input 1
5 ATEM Input 2
6 ATEM Input 3
7 Hyperdeck 4
8 Hyperdeck 5
9 Hyperdeck 3
10 VTR 3
11 VTR 4
12 Teranex 4
13 Ultrascope 1
14 Ultrascope 2
15 Ultrascope 3

VIDEO OUTPUT LOCKS:
0 U
1 U
2 U
3 U
4 U
5 U
6 U
7 U
8 U
9 U
10 U
11 U
12 U
13 U
14 U
15 U
```

## Videohub RS-422 Protocol

### General

The RS-422 protocol can be used to control many Videohub models as RS-422 slave devices, for router crosspoint switching. This feature is available on any Videohub model with an “RS-422 Control” port.

Depending on your model of Videohub, the RS-422 port may be either a DB9 or RJ11 connector. DB9 cables are commonly available in electrical stores. The RJ11 connector is the same used in many landline telephone connections. By modifying an RS-422 to USB adapter cable terminated with an RJ11 connector you can control Videohub using external controllers via USB.

In “Leitch Server” mode, these Videohub models implement the router (server) side of the Leitch Serial Pass-Through Protocol as specified in section 4 of Leitch document SPR-MAN revision D. In “Leitch Client” mode, the Videohub implements the controller (client) side of the Leitch terminal protocol.

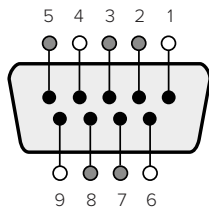

Pin	Function
1	Ground
2	Tx- (Data sent by router)
3	Rx+ (Data received by router)
4	Ground
5	NC (No connect)
6	Ground
7	Tx+ (Data sent by router)
8	Rx- (Data received by router)
9	Ground

Videohub RS-422 Router Control DB9 pin connections.

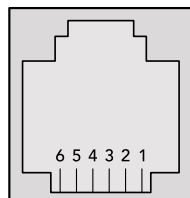

Pin No.	Function
Pin 1	TX +
Pin 2	TX -
Pin 3	GND
Pin 4	GND
Pin 5	RX -
Pin 6	RX +

Videohub RS-422 Router Control RJ11 pinout diagram.

This document describes the commands and parameters in the protocol that are relevant and supported by Videohub. Other commands and parameters specified in the Leitch protocol are accepted but ignored.

The RS-422 serial port is configured as 9600 N81.

The protocol is line-oriented, with a maximum length of 250 characters per command. Each command from the client should be terminated with a carriage-return (\r). Each response from the server will be terminated with a carriage-return and line-feed (\r\n).

Sources, destinations and levels are always specified in base-16, numbered from zero. Levels are always between 0 and 15 (“F”) . Videohubs only have one valid level - level zero.

On connecting to the serial port, the client should send a carriage-return. The Videohub Server will respond with a > character prompt, which is not followed by a carriage-return or line-feed. Receiving the prompt indicates that a connection has been established. The same prompt will be issued after each command received by the Videohub Server.

In the following documentation, commands in orange and values in blue must be typed literally, including any spaces. In the following example of an immediate command using destination port 7 and source port 3, @ X:0/destination,source would be entered as: @ X:0/6,2

## Notifications

Once connected, if status reporting is enabled, the client will receive a notification message when a route changes on the Videohub Server. The notifications take one of two forms:

S:0destination,source Routing change

This message indicates that the specified source port is now routed to the specified destination.

V:0destination,source Preset routing notification

This message indicates that the current preset includes a route from the specified source to the specified destination.

## Global Commands

All pass-through commands are preceded by an @ symbol and a space.

The following client commands are supported:

@ ! disable status reporting  
Status reporting is disabled by default.

@ ? enable status reporting  
Status reporting is enabled.

@ Z: reset routing table

Routing is reset so that the first source is routed to all destinations.

## Immediate Commands

@ X:0/destination,source change route

@ X:0/destination,source/destination-2,source-2... change multiple routes  
The specified source ports are routed to the specified destinations.  
Any routing changes will trigger S: notifications

@ X?0destination request individual route status  
The source routed to a the specified destination will be returned as an S: notification.

@ S?0 request all ports route status  
Each source & destination port pair will be returned as S: notifications

## Salvo Commands

@ P:0/destination,source queue route change

@ P:0/destination,source/destination-2,source-2... queue multiple route changes  
The specified routing changes are added to the current salvo for later execution.

@ P?0destination request individual port status in salvo  
If a routing change for the specified destination port is queued, the route will be returned as a V: notification.

- @ **V?0** request all ports status in salvo  
Each queued routing change in the salvo is reported as a **V:** notification.
- @ **B:C** clear salvo
- @ **B:R** clear salvo  
Any queued changes are discarded and the salvo is reset.
- @ **B:E** execute salvo  
Any queued changes are executed and each routing change will be returned as an **S:** notification.

# Help

## Getting Help

The fastest way to obtain help is to go to the Blackmagic Design online support pages and check the latest support material available for your Blackmagic Design Videohub.

### Blackmagic Design online support pages

The latest manual, software and support notes can be found at the Blackmagic Design support center at [www.blackmagicdesign.com/support](http://www.blackmagicdesign.com/support).

### Blackmagic Design Forum

Another useful resource is the Blackmagic Design Forum. The forum is a place to find similar questions and quick solutions from either Blackmagic staff or fellow customers with extensive knowledge.

### Contacting Blackmagic Design support

If you can't find the help you need in our support material, please use the "Send us an email" button to email a support request. Alternatively, click on the "Find your local support team" button and call your nearest Blackmagic Design support office.

### Checking the version currently installed

To check which version of Videohub Control is installed on your computer, open the Blackmagic Videohub Control application. From the Blackmagic Videohub Control menu, select About Blackmagic Videohub Control and note the version number.

### How to get the latest updates

After checking the version of your Blackmagic Videohub Control on your computer, please visit the Blackmagic Design support center at [www.blackmagicdesign.com/support](http://www.blackmagicdesign.com/support) to check for the latest updates. While it is usually a good idea to run the latest updates, it is a wise practice to avoid updating any software if you are in the middle of an important project.

# Regulatory Notices



## **Disposal of Waste of Electrical and Electronic Equipment Within the European Union.**

The symbol on the product indicates that this equipment must not be disposed of with other waste materials. In order to dispose of your waste equipment, it must be handed over to a designated collection point for recycling. The separate collection and recycling of your waste equipment at the time of disposal will help conserve natural resources and ensure that it is recycled in a manner that protects human health and the environment. For more information about where you can drop off your waste equipment for recycling, please contact your local city recycling office or the dealer from whom you purchased the product.



This equipment has been tested and found to comply with the limits for a Class A digital device, pursuant to Part 15 of the FCC rules. These limits are designed to provide reasonable protection against harmful interference when the equipment is operated in a commercial environment. This equipment generates, uses, and can radiate radio frequency energy and, if not installed and used in accordance with the instructions, may cause harmful interference to radio communications. Operation of this product in a residential area is likely to cause harmful interference, in which case the user will be required to correct the interference at personal expense.

Operation is subject to the following two conditions:

- 1 This device may not cause harmful interference.
- 2 This device must accept any interference received, including interference that may cause undesired operation.



R-R-BMD-20221109001  
R-R-BMD-20221109002  
R-R-BMD-20221109003  
R-R-BMD-20230726001  
MSIP-REM-BMD-201509007  
MSIP-REM-BMD-201503026  
MSIP-REM-BMD-201410007  
MSIP-REM-BMD-201410009  
MSIP-REM-BMD-201410010  
MSIP-REM-BMD-201410011  
MSIP-REM-BMD-201410012  
MSIP-REM-BMD-201410013  
MSIP-REM-BMD-201410014  
R-R-BMD-201912002  
R-R-BMD-201912003  
R-R-BMD-20240212003

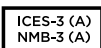

## **ISED Canada Statement**

This device complies with Canadian standards for Class A digital apparatus.

Any modifications or use of this product outside its intended use could void compliance to these standards.

This equipment has been tested for compliance with the intended use in a commercial environment. If the equipment is used in a domestic environment, it may cause radio interference.

# Safety Information

For protection against electric shock, the equipment must be connected to a mains socket outlet with a protective earth connection. In case of doubt contact a qualified electrician.

To reduce the risk of electric shock, do not expose this equipment to dripping or splashing.

Product is suitable for use in tropical locations with an ambient temperature of up to 40°C.

Ensure that adequate ventilation is provided around the product and that it is not restricted.

When rack mounting, ensure that the ventilation is not restricted by adjacent equipment.

No operator serviceable parts inside product. Refer servicing to your local Blackmagic Design service center.

Some products have the facility to connect small form-factor transceiver (SFP) optical fibre modules. Only use Laser class 1 optical SFP modules.

Recommended Blackmagic Design SFP modules:

- 3G-SDI: PL-4F20-311C



Use only at altitudes not more than 2000m above sea level.

## State of California statement

This product can expose you to chemicals such as trace amounts of polybrominated biphenyls within plastic parts, which is known to the state of California to cause cancer and birth defects or other reproductive harm.

For more information go to [www.P65Warnings.ca.gov](http://www.P65Warnings.ca.gov).

## European Office

Blackmagic Design B.V, Amsterdam Sloterdijk Teleport Towers Office 2.17,  
Kingsfordweg 151, Amsterdam, 1043GR.

## Warning for Authorized Service Personnel



Disconnect power from both power inlets before servicing!

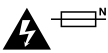

### Caution — Double Pole/Neutral Fusing

The power supply contained in this equipment has a fuse in both line and neutral conductors and is suitable for connection to the IT power distribution system in Norway.

# Warranty

## Limited Warranty

Blackmagic Design warrants that Videohub routers will be free from defects in materials and workmanship for a period of 36 months from the date of purchase excluding connectors, cables, cooling fans, fiber optic modules, fuses, keyboards and batteries which will be free from defects in materials and workmanship for a period of 12 months from the date of purchase. Blackmagic Design warrants that Videohub Master Control and Videohub Smart Control will be free from defects in materials and workmanship for a period of 12 months from the date of purchase. If a product proves to be defective during this warranty period, Blackmagic Design, at its option, either will repair the defective product without charge for parts and labor, or will provide a replacement in exchange for the defective product.

In order to obtain service under this warranty, you the Customer, must notify Blackmagic Design of the defect before the expiration of the warranty period and make suitable arrangements for the performance of service. The Customer shall be responsible for packaging and shipping the defective product to a designated service center nominated by Blackmagic Design, with shipping charges pre paid. Customer shall be responsible for paying all shipping charges, insurance, duties, taxes, and any other charges for products returned to us for any reason.

This warranty shall not apply to any defect, failure or damage caused by improper use or improper or inadequate maintenance and care. Blackmagic Design shall not be obligated to furnish service under this warranty: a) to repair damage resulting from attempts by personnel other than Blackmagic Design representatives to install, repair or service the product, b) to repair damage resulting from improper use or connection to incompatible equipment, c) to repair any damage or malfunction caused by the use of non Blackmagic Design parts or supplies, or d) to service a product that has been modified or integrated with other products when the effect of such a modification or integration increases the time or difficulty of servicing the product. THIS WARRANTY IS GIVEN BY BLACKMAGIC DESIGN IN LIEU OF ANY OTHER WARRANTIES, EXPRESS OR IMPLIED. BLACKMAGIC DESIGN AND ITS VENDORS DISCLAIM ANY IMPLIED WARRANTIES OF MERCHANTABILITY OR FITNESS FOR A PARTICULAR PURPOSE. BLACKMAGIC DESIGN'S RESPONSIBILITY TO REPAIR OR REPLACE DEFECTIVE PRODUCTS IS THE WHOLE AND EXCLUSIVE REMEDY PROVIDED TO THE CUSTOMER FOR ANY INDIRECT, SPECIAL, INCIDENTAL OR CONSEQUENTIAL DAMAGES IRRESPECTIVE OF WHETHER BLACKMAGIC DESIGN OR THE VENDOR HAS ADVANCE NOTICE OF THE POSSIBILITY OF SUCH DAMAGES. BLACKMAGIC DESIGN IS NOT LIABLE FOR ANY ILLEGAL USE OF EQUIPMENT BY CUSTOMER. BLACKMAGIC IS NOT LIABLE FOR ANY DAMAGES RESULTING FROM USE OF THIS PRODUCT. USER OPERATES THIS PRODUCT AT OWN RISK.

© Copyright 2024 Blackmagic Design. All rights reserved. 'Blackmagic Design', 'DeckLink', 'HDLink', 'Workgroup Videohub', 'Multibridge Pro', 'Multibridge Extreme', 'Intensity' and 'Leading the creative video revolution' are registered trademarks in the US and other countries. All other company and product names may be trademarks of their respective companies with which they are associated.